

ELECTRICAL SYSTEMS

4

B

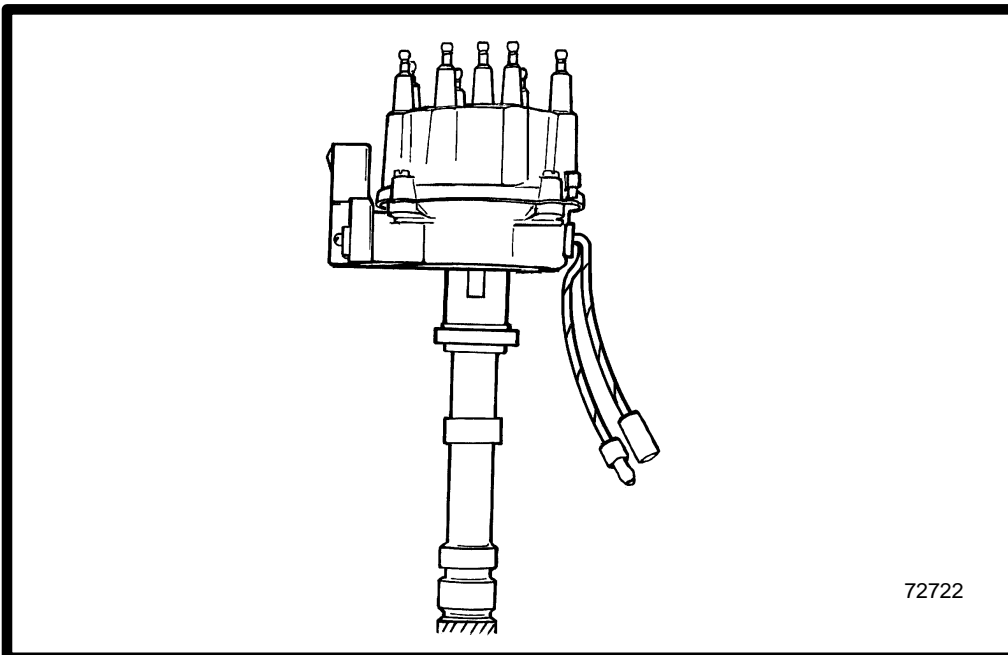

THUNDERBOLT IV AND V IGNITION SYSTEM

Table of Contents

	Page
Thunderbolt IV Ignition System	4B-1
Identification	4B-1
Replacement Parts Warning	4B-1
Thunderbolt IV (HEI) Electronic Ignition System	4B-1
Torque Specifications	4B-1
Tools/Lubricants/Sealants	4B-1
Specifications	4B-2
Coil	4B-2
Spark Plugs	4B-2
Firing Order	4B-2
Distributor Advance Curves	4B-3
Repair	4B-6
Precautions	4B-6
Distributor Cap	4B-6
Rotor/Sensor Wheel	4B-7
Sensor	4B-8
Thunderbolt IV Ignition Module	4B-9
Distributor Repair	4B-9
Removal	4B-9
Thunderbolt IV Exploded View	4B-10
Disassembly	4B-11
Reassembly	4B-11
Distributor Installation	4B-12
Engine Not Disturbed	4B-12
Engine Disturbed	4B-12

	Page
Thunderbolt IV Ignition Timing	4B-13
Thunderbolt V Ignition System	4B-14
Identification	4B-14
General Description	4B-15
Idle Speed Spark Control	4B-15
Acceleration Spark Advance	4B-15
Mean-Best-Timing (MBT) Spark Advance	4B-15
Over-Speed Control	4B-15
Knock Retard Spark Control	4B-15
Thunderbolt V Spark Control Graph	4B-16
Circuit Description	4B-17
Ignition Control Module	4B-17
Knock Control Module	4B-17
Ignition Control System Timing Lead	4B-17
Ignition System Wiring Diagram	4B-18
Timing and Idle Adjustment Procedures For Thunderbolt V Ignition	4B-19
Setting Base Ignition Timing	4B-19
Adjusting Idle Mixture	4B-19
Adjusting Engine Idle Speed	4B-19
Troubleshooting Thunderbolt V Ignition	4B-20
Ignition Control Module / Coil / Distributor	4B-20
Knock Control Module	4B-21
Spark Plugs	4B-22
Spark Plug Wires	4B-23

NOTICE

For information and procedures on troubleshooting, refer to Section 1C.

Thunderbolt IV Ignition System

Identification

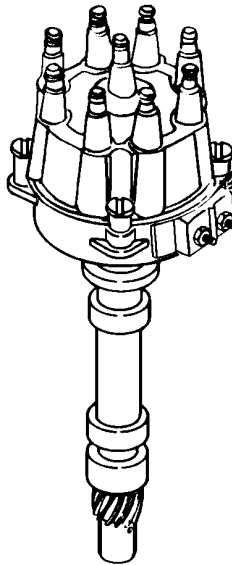

71790

DISTRIBUTOR WITH IGNITION MODULE MOUNTED ON EXHAUST ELBOW

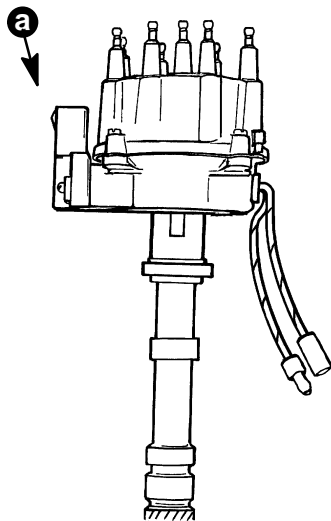

72722

DISTRIBUTOR WITH IGNITION MODULE MOUNTED ON DISTRIBUTOR BODY

a - Ignition Module

NOTE: Except for ignition module replacement, repair procedures for both distributors are the same.

Replacement Parts Warning

⚠ WARNING

Electrical, ignition and fuel system components on your MerCruiser are designed and manufactured to comply with U.S. Coast Guard Rules and Regulations to minimize risks of fire and explosion.

Use of replacement electrical, ignition or fuel system components, which do not comply with these rules and regulations, could result in a fire or explosion hazard and should be avoided.

Thunderbolt IV (HEI) Electronic Ignition System

Torque Specifications

Fastener Location	In. Lb.	Ft. Lb.	N-m
Distributor Clamp		20	27
Spark Plugs (14 mm)		15	20
Ignition Module Retaining Screws (Stainless Steel)	10		1.1

Tools/Lubricants/Sealants

Description	Part Number
Timing Light	91-99379
Multi-Meter / DVA	91-99750
Torch Lamp	91-63209
Insulating Compound	92-41669--1
Quicksilver Liquid Neoprene	92-27511-2
Loctite 271	Obtain Locally
Thermalconductive Grease	

Specifications

Coil

Description	Specification
Coil Part Number	392-7803A4
Primary Resistance	.60-.80 Ohms
Secondary Resistance	9,400-11,700 Ohms

Spark Plugs

Model	All MIE and MCM Except Gen+ Engines
Spark Plug	.040 In. (1 mm)
Spark Plug Type	AC-MR43T NGK BR6FS Champion RV15YC4

Model	All MIE and MCM Gen+ Engines
Spark Plug	.045 In. (1.1 mm)
Spark Plug Type	AC-MR43LTS NGK BPR6EFS Champion RS12YC

Firing Order

Firing Order 1-8-4-3-6-5-7-2

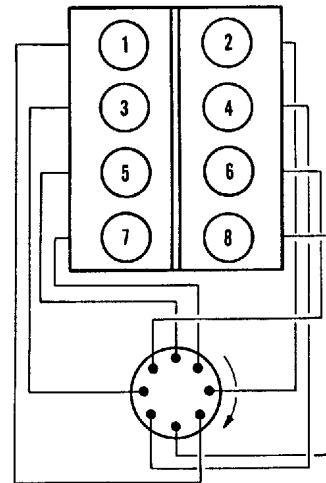

72008

Distributor Advance Curves

MCM 5.0L ALPHA/MCM 5.0LX ALPHA/MCM 5.0L BRAVO

IMPORTANT: Distributor advance curve charts do not include the initial engine timing. Basic initial timing must be added to chart for total advance curve. The spark advance is controlled by the ignition module.

Identification Mark: V8-22
Module Advance: 22 Degrees
Initial Timing: 8 Degrees BTDC
Total Advance: 30 Degrees

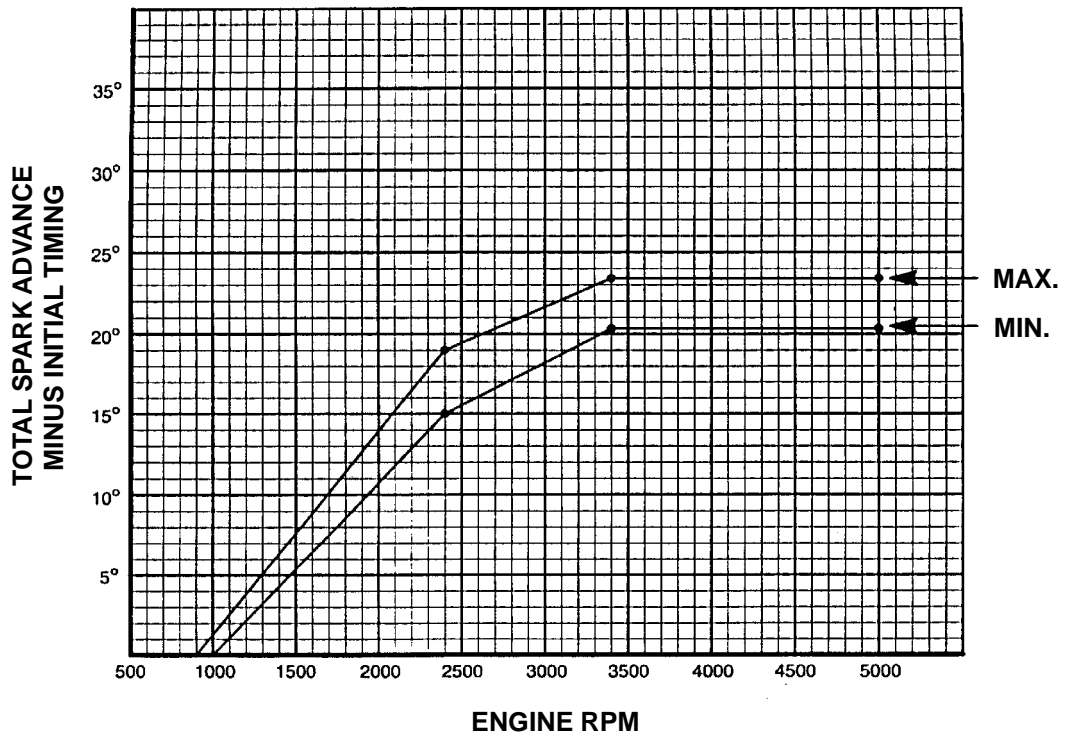

72723

MCM 5.7L ALPHA/MIE 5.7L

IMPORTANT: Distributor advance curve charts do not include the initial engine timing. Basic initial timing must be added to chart for total advance curve.

IMPORTANT: The spark advance is controlled by the ignition module.

Identification Mark: V8-22A
Module Advance: 22 Degrees
Initial Timing: 8 Degrees BTDC
Total Advance: 30 Degrees

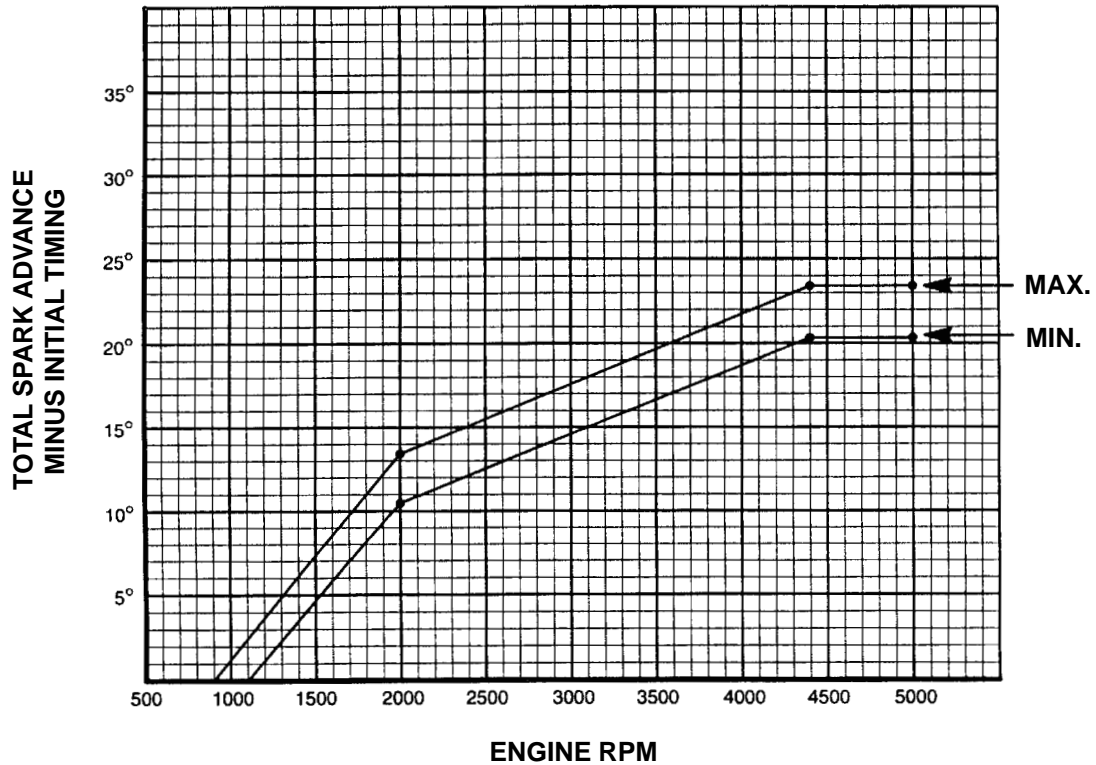

72724

MCM 5.7L BRAVO/MCM 350 MAGNUM ALPHA/MIE 5.7L COMPETITION SKI/MIE 350 MAGNUM TOURNAMENT SKI

IMPORTANT: Distributor advance curve charts do not include the initial engine timing. Basic initial timing must be added to chart for total advance curve.

IMPORTANT: The spark advance is controlled by the ignition module.

Identification Mark: V8-24S
Module Advance: 24 Degrees
Initial Timing: 8 Degrees BTDC
Total Advance: 32 Degrees

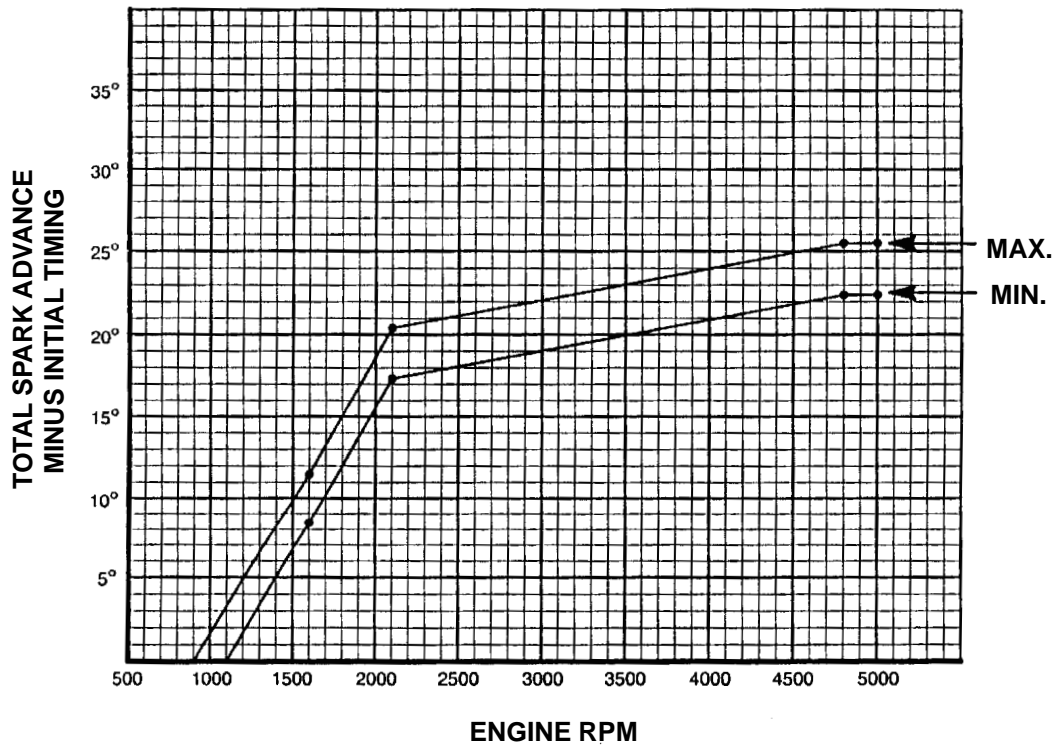

72725

Repair

Precautions

⚠ WARNING

When performing the following procedure, be sure to observe the following:

- Be sure that engine compartment is well ventilated and that no gasoline vapors are present, to avoid the possibility of fire.
- Be sure to keep hands, feet and clothing clear of moving parts.
- Do not touch or disconnect any ignition system parts while engine is running.
- Do not reverse battery cable connections. System is negative (-) ground.
- Do not disconnect battery cables while engine is running.

Distributor Cap

1. Loosen four distributor cap retaining screws.
2. Remove distributor cap.
3. Clean cap with warm soap and water and blow off with compressed air.
4. Check cap contact for excessive burning or corrosion. Check center contact for deterioration.
5. Check cap for cracks or carbon tracks using magneto analyzer.

IMPORTANT: If high tension leads are removed from cap refer to "Spark Plug Wires" in this section and the following illustrations for installation.

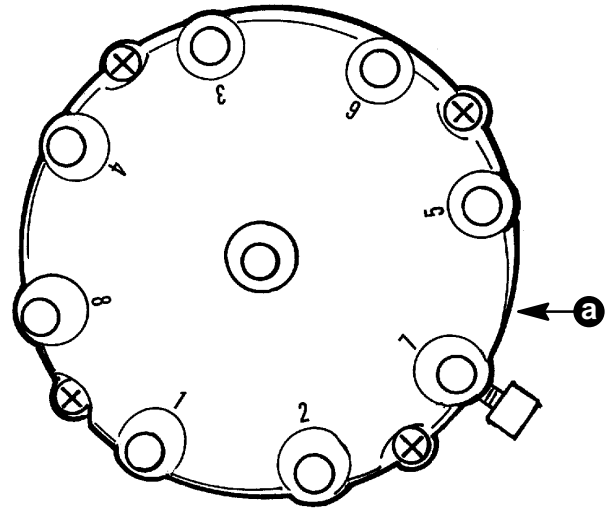

72726

a - Alignment Notch

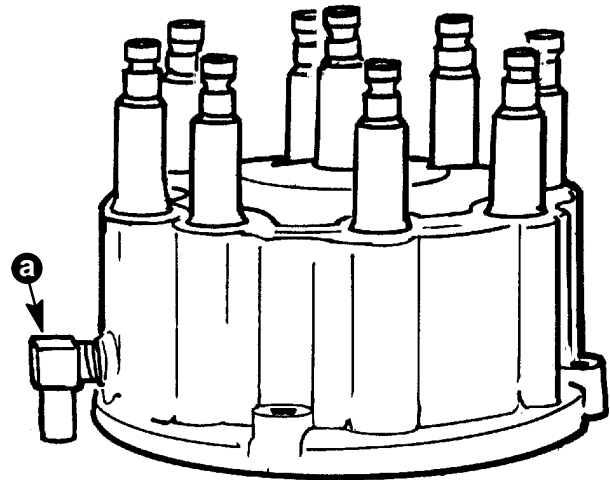

72728

a - Vent

Rotor/Sensor Wheel

1. Remove distributor rotor/sensor wheel assembly from distributor shaft. Rotor and sensor wheel are secured to the shaft with Loctite. Use two flat blade screwdrivers. The screwdrivers are positioned opposite each other with the blade tips on the underside of the rotor and sensor wheel assembly. Make sure blade tips are toward distributor shaft until they come in contact with shaft. A downward push on both screwdriver handles at the same time will pry off rotor/sensor wheel assembly. The use of torch lamp will also aid in the removal of the rotor/sensor wheel assembly.

⚠ WARNING

Wear protective gloves when handling heated rotor/sensor wheel assembly to avoid severe burns.

2. With the rotor/sensor wheel assembly removed, inspect the locating key inside the rotor.
3. The locating key will appear as a clean edged, 1/8 in. (3 mm) wide, sloped ramp at the bottom of the splined hole.

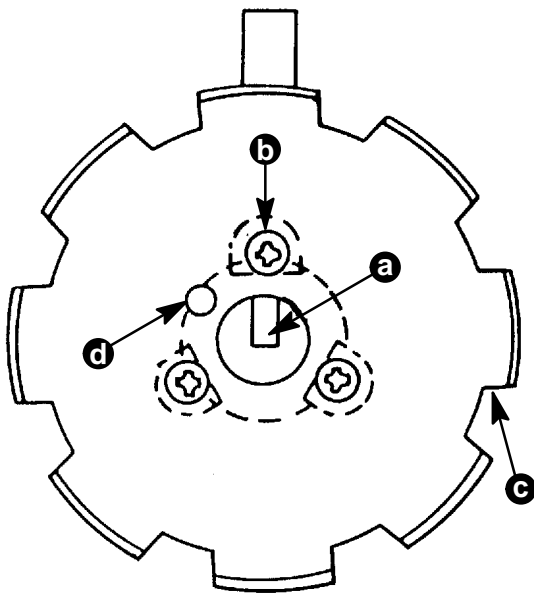

72730

- a - Locating Key
- b - Screws
- c - Sensor Wheel
- d - Locating Pin

IMPORTANT: If there is any doubt if sensor wheel is located properly, lay sensor wheel on top of the figure above with sensor fingers facing up (toward you). Line up three screw holes and locating pin hole on sensor wheel with the figure. If wheel is indexed properly all the fingers on wheel will line up with those in the figure.

4. If there are pieces of material shaved off the key or if it appears to have been damaged by being forced down while misaligned with slot in distributor shaft, the rotor must be replaced.
5. Check rotor for burned or corroded center contact.
6. Check rotor for cracks and carbon tracks using magneto analyzer and instructions supplied with analyzer.
7. If rotor is damaged, replace rotor by removing three hex bolts and separating sensor wheel from rotor. Reinstall sensor wheel to new rotor making sure locating pin on rotor is installed in locating hole in sensor wheel. Tighten three hex bolts securely.
8. Bend carbon brush tang upward slightly until a distance of 1/4 in. (6 mm) is obtained between rotor and tang.

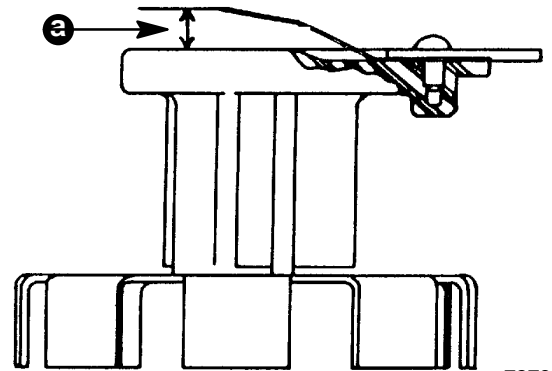

72731

a - 1/4 in. (6 mm)

9. Put 2 drops of Loctite 271 into the rotor so it lands on the locating key.
10. Put 2 drops of Loctite 271 in keyway on upper portion of distributor shaft.
11. Immediately install rotor assembly onto distributor shaft. Make sure rotor locating key is aligned with keyway in distributor shaft before pressing rotor all the way down on the shaft, until it stops, with the palm of your hand. Let Loctite cure overnight with distributor in inverted position.

IMPORTANT: The rotor should fit very tight. It may be necessary to heat rotor with torch lamp to properly install. It is important not to let any Loctite run down distributor shaft. Loctite could get into top distributor housing bushing.

12. Reinstall distributor cap on distributor.
13. Install spark plug wires (if removed). Refer to "Spark Plug Wires" in this section.

Sensor

1. Remove rotor and sensor wheel.
2. Disconnect sensor wires.
3. Remove two screws that hold sensor into distributor housing. Remove sensor from housing.

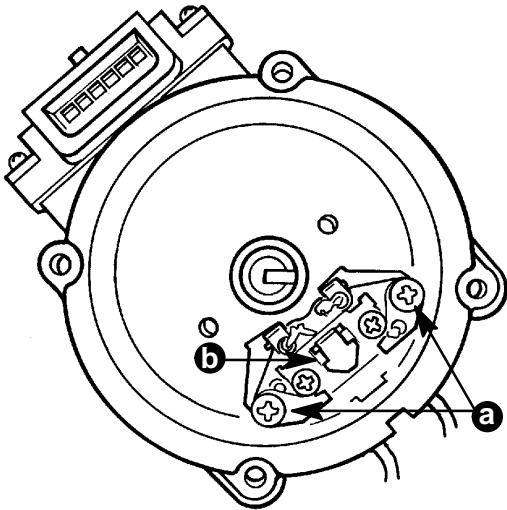

72732

- a - Mounting Screws
- b - Sensor Assembly

4. Use a magnifying glass and light to inspect the two metal "jumper leads" for cracks. If a crack is found in either metal "jumper lead," install a new sensor.

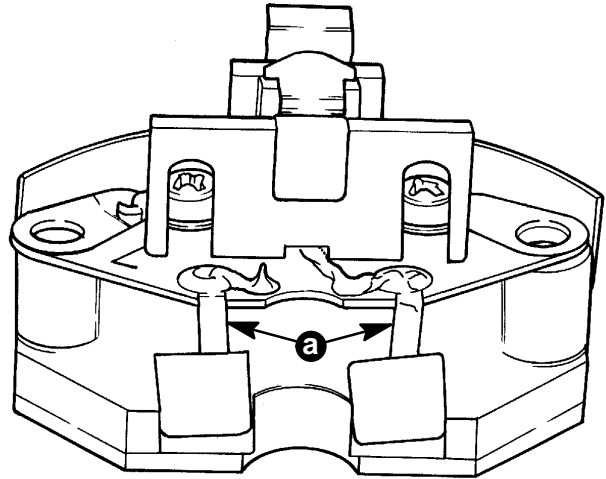

72733

- a - Jumper Leads

CAUTION

Do not use any type of silicone sealer on the inside of the distributor. Most silicone sealers give off an acidic vapor during the curing stage of the sealer. This acid can cause corrosion on the ignition components.

5. Install sensor into housing and install two retaining screws.
6. Install sensor wheel, rotor, and distributor cap.
7. Connect WHT/RED and WHT/GRN sensor wires (ring terminals on engine harness wires, or bullet connectors from ignition module wires). Tighten hex nuts securely, if so equipped.

Thunderbolt IV Ignition Module

IGNITION MODULE MOUNTED ON EXHAUST ELBOW

1. Unplug wiring harness connector from ignition module.
2. Remove fasteners and hardware retaining ignition module to exhaust elbow. Remove module.

NOTE: Do not disturb spacers between ignition module plate and exhaust elbow, unless replacing spacers.

IMPORTANT: BLACK ground (-) wire from engine harness must be placed under ignition module fastener when mounting module.

3. Replace ignition module using existing hardware. Tighten fasteners securely. Be certain BLACK ground (-) wire is in position.
4. Check that terminals of wiring harness connector are clean and free of corrosion. Plug connector into ignition module.

IGNITION MODULE MOUNTED ON DISTRIBUTOR

1. Unplug wiring harness connector from ignition module.
2. Remove stainless steel screws retaining ignition module to distributor body. Remove module.

IMPORTANT: Thermalconductive Grease must be applied to the back of the ignition module to conduct heat away from the module and to prevent corrosion.

3. Apply a thin coat of Thermalconductive Grease evenly across the metal back of the ignition module.
4. Install ignition module using the stainless steel screws. Torque screws to 10 lb. in. (1.1 N·m).
5. Check that terminals of wiring harness connector are clean and free of corrosion. Plug connector into ignition module.

Distributor Repair

Removal

1. Unplug wiring harness from ignition module on distributor housing, or disconnect wires from ignition module mounted on exhaust elbow. Disconnect sensor wires.
2. Remove distributor cap. Do not remove high tension leads unless necessary.
3. Crank engine over until timing marks line up and rotor is pointing toward No. 1 cylinder on distributor cap.
4. Mark distributor housing in reference to engine block.
5. Remove bolt and hold-down clamp and remove distributor.

IMPORTANT: To simplify distributor installation, do not turn crankshaft when distributor is removed from engine.

Thunderbolt IV Exploded View

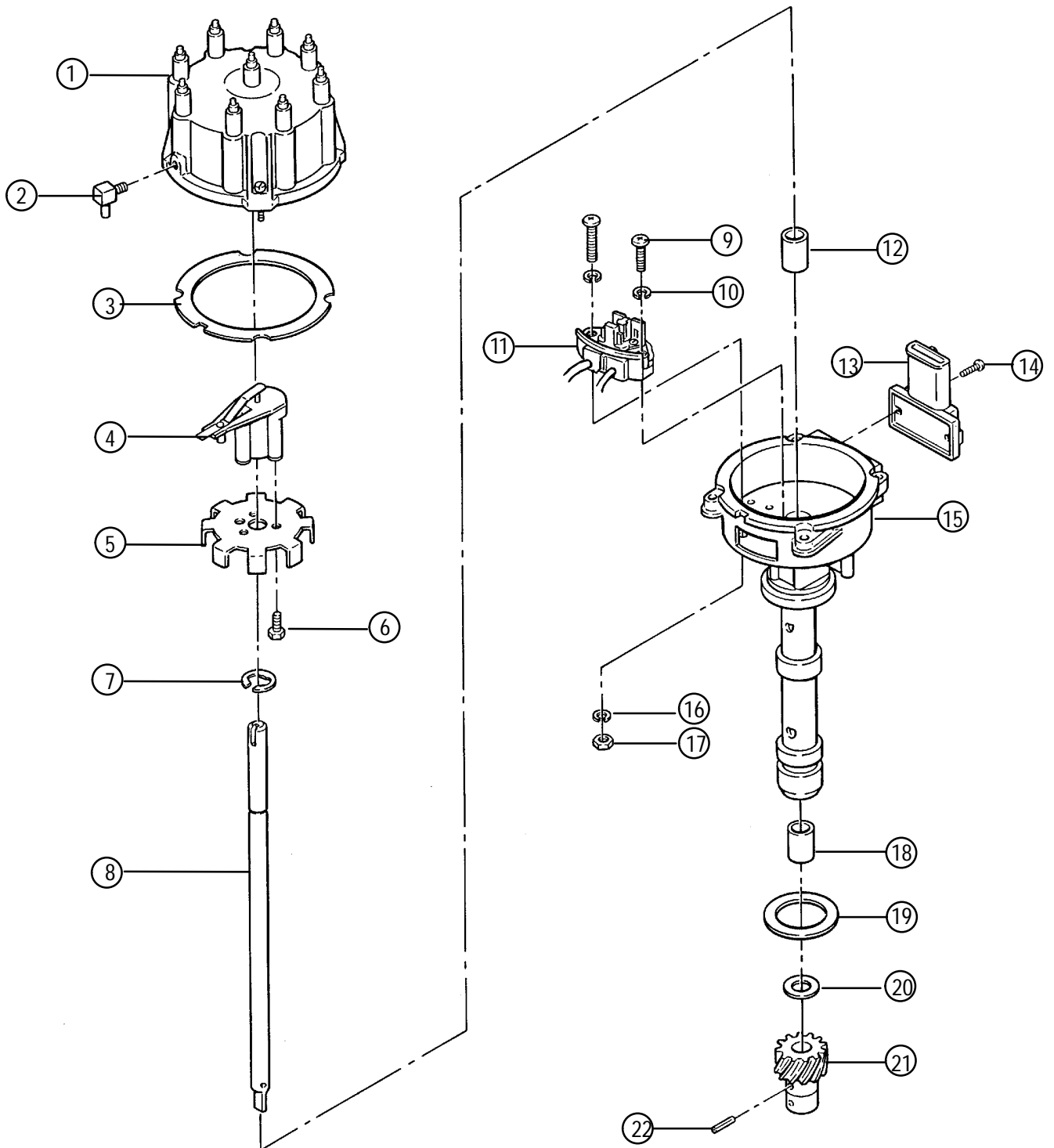

72058

- 1 - Distributor Cap
- 2 - Vent
- 3 - Gasket
- 4 - Rotor
- 5 - Sensor Wheel
- 6 - Screws (5)
- 7 - E-Clip
- 8 - Shaft
- 9 - Screws (2)
- 10 - Lockwashers (2)
- 11 - Sensor
- 12 - Upper Bushing
- 13 - Ignition Module , If Equipped (Apply Thermalconductive Grease)
- 14 - Screws (2)
- 15 - Distributor Housing
- 16 - Lockwasher
- 17 - Nut
- 18 - Lower Bushing
- 19 - Gasket
- 20 - Washer
- 21 - Gear
- 22 - Roll Pin

Disassembly

NOTICE

Refer to exploded view preceding for parts identification during disassembly and reassembly.

1. Remove rotor, sensor wheel, sensor, and ignition module (if mounted on distributor), as previously outlined.
2. Remove roll pin, washer and driven gear from distributor shaft.
3. Check for side play between shaft and distributor housing bushings. Maximum side play is .002 in. (0.05 mm).
4. Remove shaft from housing and check shaft for being bent with a dial indicator and V-blocks. Maximum runout is .002 in. (0.5 mm).

Reassembly

1. Lubricate shaft with engine oil. Install E-clip (if removed) on shaft in housing.
2. Install washer on shaft. Install original gear; slide onto shaft and install roll pin.

IMPORTANT: Hole may be offset and gear will only fit in one direction.

3. If installing a new gear, the gear will come drilled on one side. Slide gear onto shaft; align hole in gear with hole in shaft. Using these holes as guides, drill through other side of gear with a 3/16 in. carbide tripped drill.

IMPORTANT: If a new gear has only a dimple, you will have to drill through one side of the gear before you slide gear onto shaft. In most cases it is recommended to have a machine shop complete the drilling operation for new gear installation.

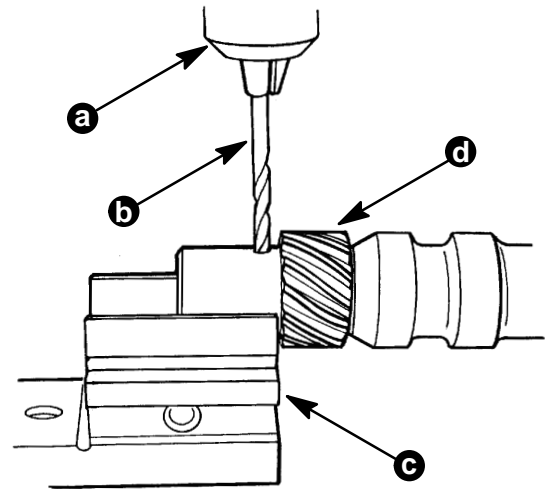

- a - Drill Press
- b - 3/16 in. Carbide Tip Drill
- c - V-Block
- d - New Gear

4. Install sensor, sensor wheel, rotor, and ignition module (if mounted on distributor), as previously outlined.
5. Install distributor as outlined in "Distributor Installation."

72735

Distributor Installation

Engine Not Disturbed

1. Install new gasket on distributor housing.
2. Turn rotor approximately 1/8-turn in a counter-clockwise direction past mark previously scratched on distributor housing.
3. Work distributor down into position in engine block with distributor positioned as noted during removal.

IMPORTANT: It may be necessary to move rotor slightly to start gear into mesh with camshaft gear, but rotor should line up with the mark when distributor is down in place. Distributor shaft must enter oil pump shaft for complete installation.

4. Replace and tighten distributor hold-down bolt and clamp. Connect distributor ground (-) leads.
5. Install cap. Refer to "Spark Plug Wires" and install wires.
6. Plug wiring harness into ignition module on distributor housing, on distributors so equipped. Connect wires from ignition module to distributor terminals, on all models.
7. Coat any exposed terminals with Quicksilver Liquid Neoprene.
8. Time ignition as outlined under "Ignition Timing."

Engine Disturbed

1. Locate No. 1 piston in firing position by following instructions "a" or "b":
 - a. Remove No. 1 spark plug and, with finger on plug hole, crank engine until compression is felt in No. 1 cylinder. Continue cranking until pointer lines up with timing mark on crankshaft pulley.

- b. Remove rocker cover and crank engine until No. 1 intake valve closes, continuing to crank slowly until pointer lines up with timing mark on crankshaft pulley.

2. Position distributor to opening in block in normal installed attitude.

IMPORTANT: Make sure oil pump shaft is engaged in the following. Position (align) oil pump shaft end to engage bottom of distributor drive gear prior to inserting distributor if necessary.

3. Position rotor to point toward No. 1 cylinder on cap (with distributor housing held in installed attitude), then turn rotor counterclockwise approximately 1/8-turn more and work distributor down to engage camshaft and oil pump shaft. It may be necessary to rotate rotor slightly until engagement is felt.

CAUTION

Avoid severe engine damage. Do not attempt to force distributor into position using hold-down clamp and bolt.

4. When distributor housing contacts intake manifold, camshaft and oil pump shaft are engaged. Install hold-down clamp and bolt and snug up bolt.
5. Connect distributor ground (-) leads, if so equipped.
6. Place distributor cap in position and check that rotor lines up with terminal for No. 1 spark plug. Install new gasket on distributor housing. Install cap.
7. Refer to "Spark Plug Wires" and install wires. Refer to "Specifications" for firing order.
8. Plug wiring harness into ignition module on distributor housing, on distributors so equipped. Connect wires from ignition module to distributor terminals, on all models.
9. Coat any exposed terminals with Quicksilver Liquid Neoprene.
10. Time ignition as outlined under "Ignition Timing."

Thunderbolt IV Ignition Timing

1. Connect timing light (91-99379 or similar) to No. 1 spark plug. Connect power supply leads on light to 12 volt battery. Refer to "Specifications" for cylinder numbering and location.
2. Connect tachometer to engine.
3. Start engine and run at normal idle speed.
4. Aim timing light at timing tab, located on timing gear cover and crankshaft torsional damper.

IMPORTANT: GM engine timing marks (on tab) are in 2-degree increments. MCM and MIE LH engines will have "A" (Advance) mark to the left of "0." Timing must be set on the "A" side of "0" (Top Dead Center).

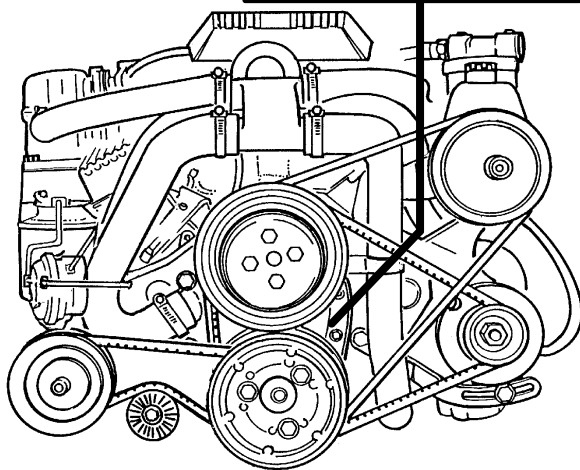
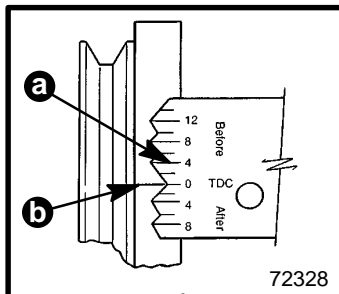

- a - Degree Marks
- b - Timing Mark

5. Adjust timing by loosening distributor clamp and rotating distributor body as required until timing mark on damper or pulley lines up with the mark on tab specified in "Specifications." Tighten clamp and recheck location of timing mark.
6. Stop engine and remove timing light.

Thunderbolt V Ignition System

Identification

The Thunderbolt V ignition system uses the same distributor as the Thunderbolt IV system. The Ignition Control Module and Knock Control Module are mounted with the ignition control module.

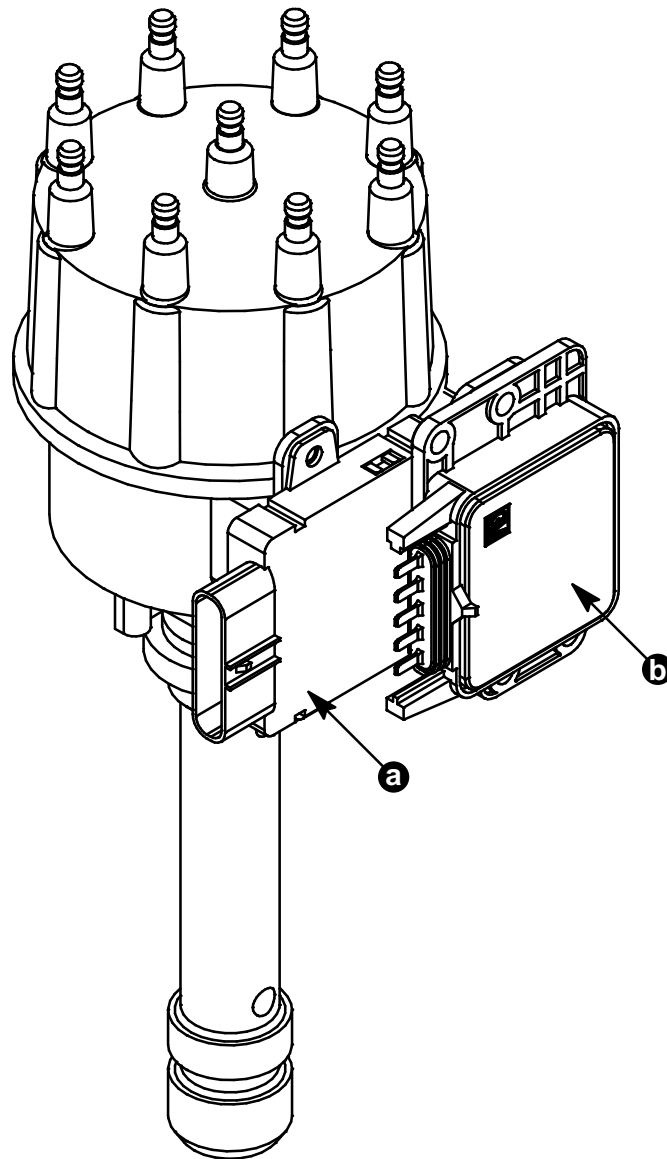

73999

a - Ignition Control Module

b - Knock Control Module

General Description

The Thunderbolt V ignition system has several spark control features that will be described following:

- Idle Speed Spark Control
- Acceleration Spark Advance
- Mean-Best-Timing Spark Advance
- Over-Speed Control (Rev-Limiter)
- Knock Retard Spark Control

NOTE: *The Ski models do not have the Mean Best Timing feature.*

Idle Speed Spark Control

The ignition module will control ignition timing to maintain a calibrated idle speed. This is accomplished by making small spark advance adjustments. This feature is only active within a certain RPM range. This range may be slightly different from one engine model to another. The approximate range is 400-700 RPM.

Acceleration Spark Advance

This feature is active during acceleration only. When accelerating, the ignition module may add more spark advance to the “Base Spark Timing Curve”. The amount of spark advance added, is totally dependant on how fast RPM increases (how fast the throttle is moved). This feature is also active within a certain RPM range. This range may be slightly different from one engine model to another. The approximate RPM range for this feature is 1200-4000 RPM. Within this range, the module can add approximately 10 degrees of spark advance to the base spark timing curve.

Mean-Best-Timing (MBT) Spark Advance

During light load cruising, the ignition module searches for the optimal ignition timing. This is also accomplished by small changes to the spark advance. At a given RPM, the module will try to add a small amount of advance and wait to see if there is an RPM change. If RPM increases, it will try to increase timing more. The module will continue to advance timing until it no longer gets an increase in RPM. Conversely, if it senses an RPM drop, it will start to retard some of the spark timing. The approximate RPM range for this feature is 1200-4000 RPM. Within this range, the ignition module can add approximately 10-15 degrees of spark advance to the base spark timing curve.

NOTE: *The Audio Warning System is also connected into the ignition module circuit. If the audio warning system becomes activated by the closing of one of the audio warning system switches, the MBT feature is deactivated.*

Over-Speed Control

The ignition module will prevent the engine speed from exceeding a preset limit by stopping the spark. This feature has an RPM range that varies from model to model. The over-speed limit for a particular engine is set slightly higher than the top end of the RPM range for that model. For example, if the recommended range is 4600-5000 RPM, the over-speed limit would be set at 5100 RPM. When RPM reaches this limit, spark is turned-off until engine RPM drops down to a “Reset RPM”, which would be approximately 4750 RPM for this example. At this point, spark comes back on.





Knock Retard Spark Control

The knock control feature helps provide protection from harmful detonation. Knock control is handled by the Knock Control Module. This module receives a signal from a sensor that is mounted on the engine block. The knock control module works in conjunction with the ignition module to retard the timing if spark knock is present.

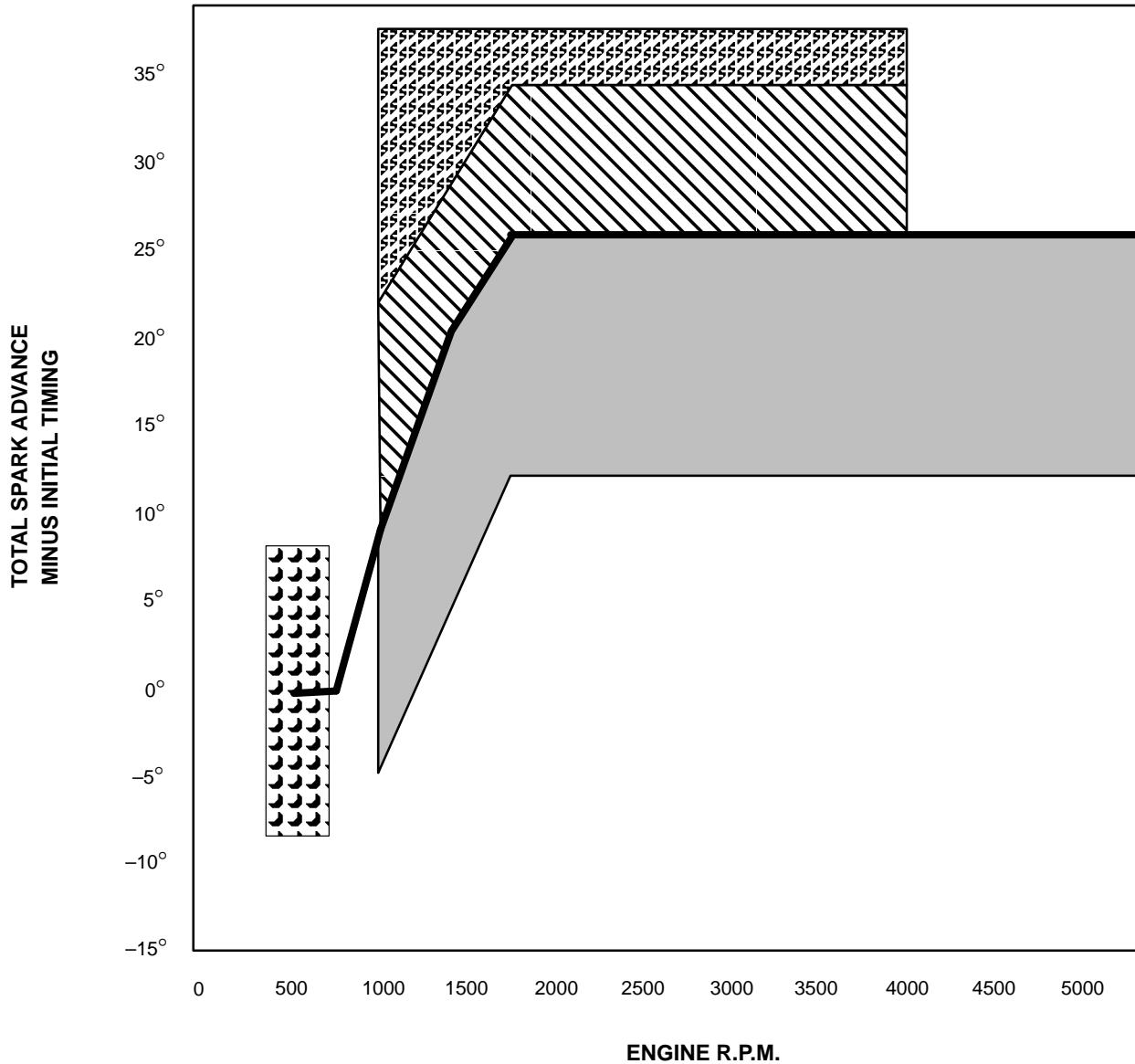
Thunderbolt V Spark Control Graph

IMPORTANT: The graph below shows the typical advance ranges for a Thunderbolt V ignition control module. The numbers plotted on the graph are not representative of any particular model. It is only presented to provide an understanding of how the system functions.



- = Base Timing Advance Curve
-  = Idle Speed Advance Range
-  = Knock Retard Range
-  = Acceleration Advance Range
-  = MBT Advance Range

Circuit Description

Refer to the circuit wiring diagram on the following page for reference to this circuit description.

Ignition Control Module

- The ignition module receives its power (+) thru the PURPLE wire “9”.
- Ignition module ground (–) is accomplished thru the BLACK wire “10”.
- There is also a Case Ground (–) wire “12” that is connected to one of the ignition module attaching screws.
- The 12 volt signal from the ignition module to the distributor is carried thru the WHITE/RED wire “8”, to the distributor sensor and back to the ignition module thru the WHITE/GREEN wire “7”.
- The tachometer signal is carried to the instrument panel thru the GRAY wire “11”.
- The PURPLE/WHITE wire “3” carries the signal from the knock control module to the ignition control module.
- There are two BLACK wires “5” that have bullet connectors. This circuit is reserved for future options. On current models, the two BLACK wires must be connected for the system to function properly.
- The TAN/BLU wire “6” carries a signal from the Audio Warning circuit to the ignition module.

Knock Control Module

- The knock control module receives its power (+) from the PURPLE wire “4”.
- Knock module ground (–) is accomplished thru the BLACK wire “2”.
- The PURPLE/WHITE wire “3” carries the signal from the knock control module to the ignition control module.
- The BLUE wire “1” carries the signal from the knock sensor to the knock module.

Ignition Control System Timing Lead

The ignition control system has a lead with bullet connector “11” that is connected into the PURPLE/WHITE wire “3”. This lead is used for performing the following tests and procedures:

- Setting “Base Ignition Timing”
- Setting “Engine Idle Speed”
- Setting “Idle Mixture”
- Testing Knock Control Circuit

This lead, when connected to an engine ground (–), locks the ignition control module into the “Base Timing” mode.

Ignition System Wiring Diagram

- BLK = BLACK
- BLU = BLUE
- BRN = BROWN
- GRY = GRAY
- GRN = GREEN
- ORN = ORANGE
- PNK = PINK
- PUR = PURPLE
- RED = RED
- TAN = TAN
- WHT = WHITE
- YEL = YELLOW
- LIT = LIGHT
- DRK = DARK

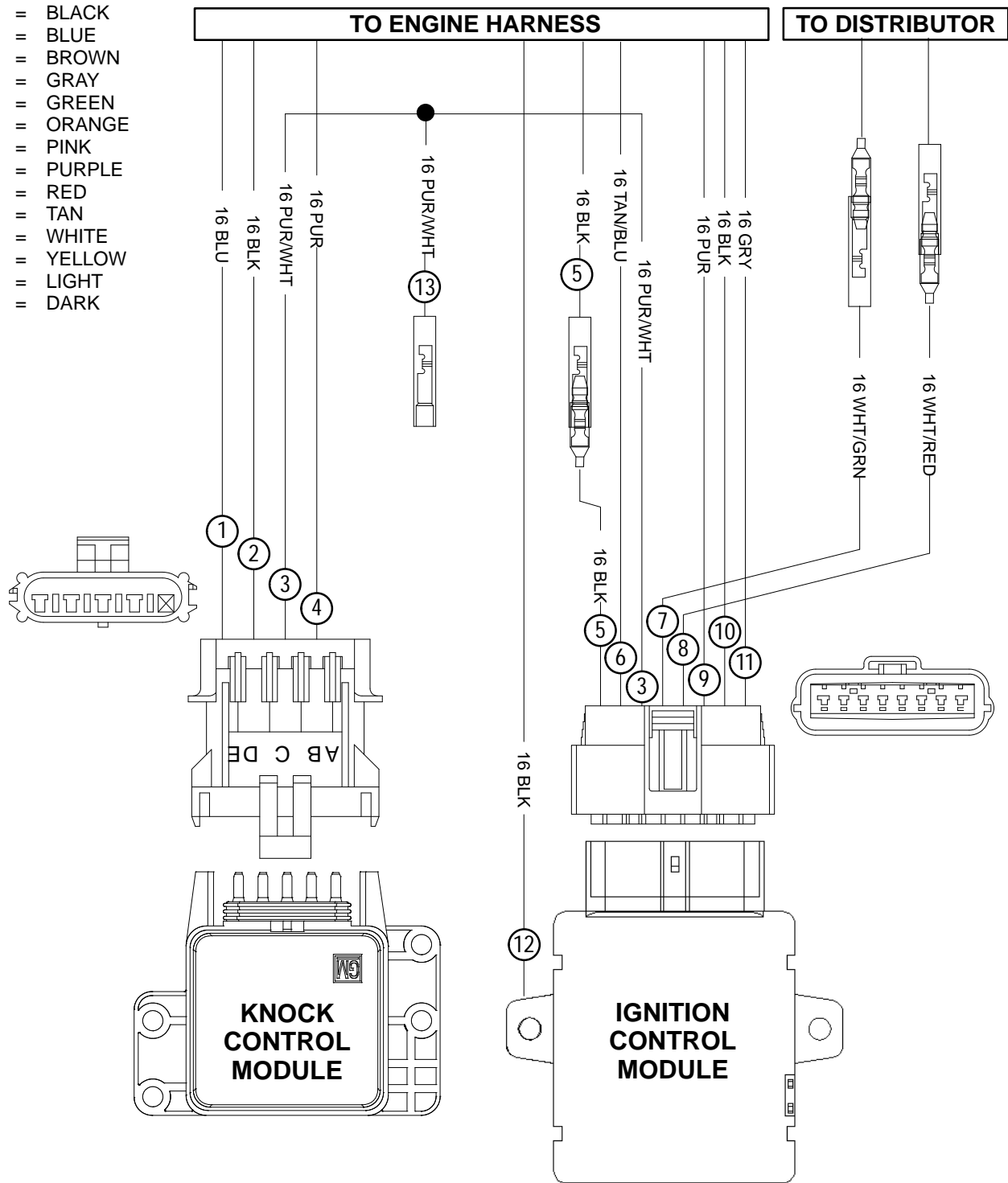

- 1 - Knock Sensor Wire
- 2 - Ground Wire (-) For Knock Module
- 3 - Knock Module Signal Wire
- 4 - Battery (+) Positive Wire To Knock Module
- 5 - Ground (-) For Future Options
- 6 - Audio Warning System Wire
- 7 - Distributor Wire

- 8 - Distributor Wire
- 9 - Battery (+) Positive Wire To Ignition Module
- 10- Ground Wire For Ignition Module
- 11- Tachometer Wire
- 12- Ignition Module Case Ground (-)
- 13- Timing Lead (For Setting Timing and Other Tests)

Timing and Idle Adjustment Procedures For Thunderbolt V Ignition

Setting Base Ignition Timing

1. Connect timing light to number 1 spark plug. Connect timing light power supply leads (if applicable) to 12 volt source.
2. Connect a shop tachometer to engine.
3. Using a jumper wire, connect the ignition system timing lead "13" (PUR/WHT wire) to a good engine ground (-). This locks the ignition module into the "Base Timing Mode".
4. Start engine and run at normal idle speed. Allow engine to reach normal operating temperature.
5. Aim timing light at timing tab, located on the timing gear cover and crankshaft torsional damper.
6. Adjust timing using the conventional method.

IMPORTANT: Be sure to disconnect the jumper wire from the ignition system test terminal before attempting to resume normal operations. If the jumper wire is left in place, the ignition module will operate in the "Base Timing Mode". This means that the additional timing advance features would not function.

7. Make sure that the distributor has been tightened. Remove the jumper wire from the timing terminal.
8. Stop engine and remove timing light.

Adjusting Idle Mixture

The procedure for adjusting carburetor idle mixture can be found in the appropriate engine service manual. This procedure also requires that the ignition module be locked in the "Base Timing Mode".

IMPORTANT: In order to properly set idle mixture, the ignition module MUST BE locked in the "Base Timing Mode". This is necessary because of the "Idle Speed Control" feature that exists in the ignition module. See information on the previous pages about this feature.

1. Using a jumper wire, connect the ignition system timing lead "13" (PUR/WHT wire) to a good engine ground (-). This locks the ignition module into the "Base Timing Mode".
2. Adjust idle mixture following the procedure in the appropriate engine service manual.
3. Remove the jumper wire from the timing terminal.

Adjusting Engine Idle Speed

This procedure should be done with boat in the water, drive unit in neutral and engine at normal operating temperature. Refer to the Operation and Maintenance Manual for the correct idle speed.

1. Disconnect the throttle cable from carburetor.

IMPORTANT: In order to properly set idle speed, the ignition module MUST BE locked in the "Base Timing Mode". This is necessary because of the "Idle Speed Control" feature that exists in the ignition module. See information on the previous pages about this feature.

2. Connect a shop tachometer to engine.
3. Using a jumper wire, connect the ignition system timing lead "13" (PUR/WHT wire) to a good engine ground (-). This locks the ignition module into the "Base Timing Mode".
4. Start engine and allow it to reach normal operating temperature.
5. Adjust idle speed to recommended RPM.
6. Stop engine. Readjust cable barrel and reinstall the throttle.

IMPORTANT: Be sure to disconnect the jumper wire from the ignition system test terminal before attempting to resume normal operations. If the jumper wire is left in place, the ignition module will operate in the "Base Timing Mode". This means that the additional timing advance features would not be functioning.

7. Remove the jumper wire from the timing terminal.

Troubleshooting Thunderbolt V Ignition

Ignition Control Module / Coil / Distributor

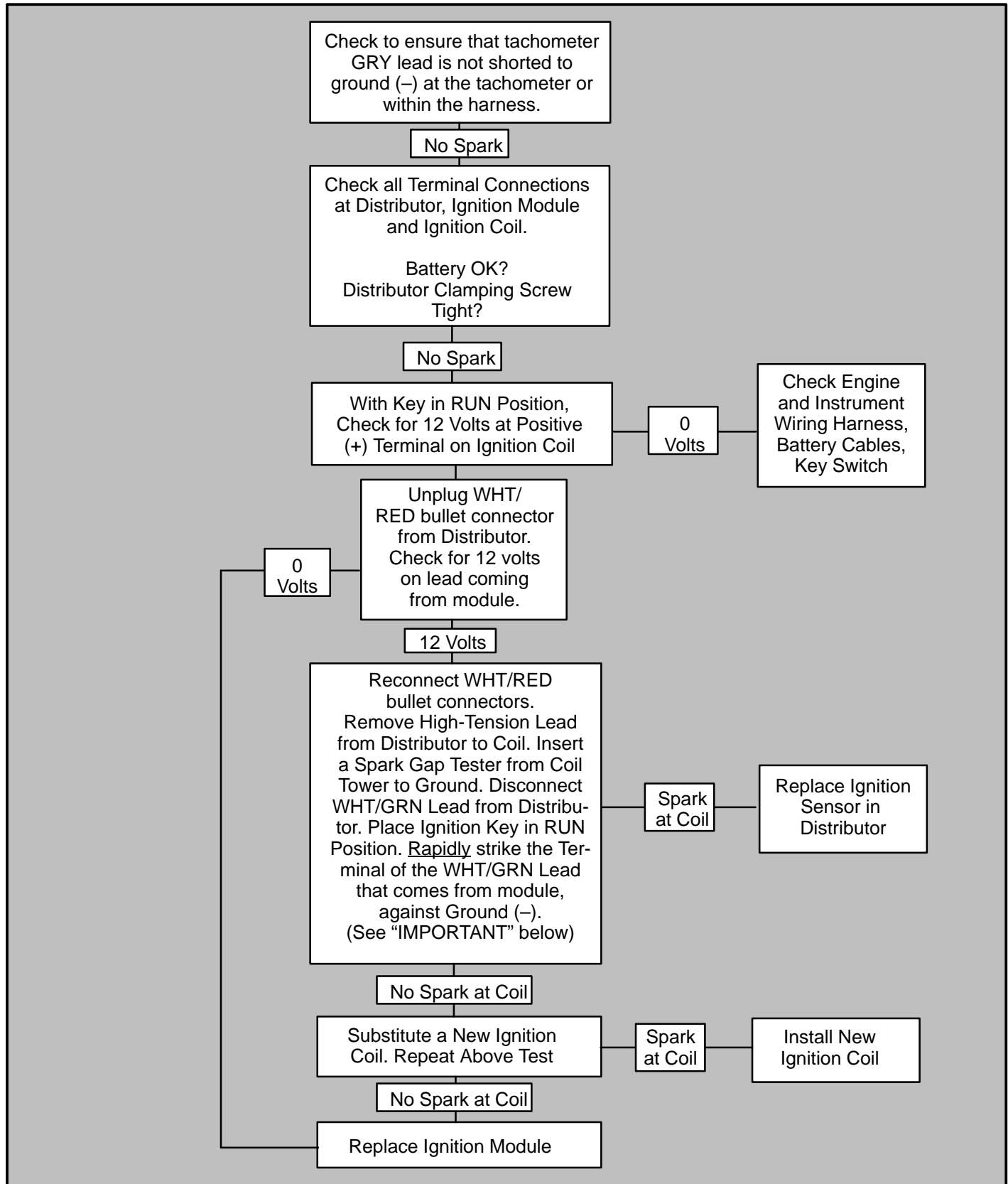

IMPORTANT: The WHT/GRN lead must be touched against ground (-) 2-3 times per second to simulate a running engine. Repeat this test several times to ensure that spark is present.

Knock Control Module

The Knock Control Module contains solid state circuitry which monitors the knock sensor's AC voltage signal and then supplies an 8-10 volt signal, if no spark knock is present, to the Ignition Control Module. If spark knock is present, the Knock module will remove the 8-10 volt signal to the Ignition Control Module.

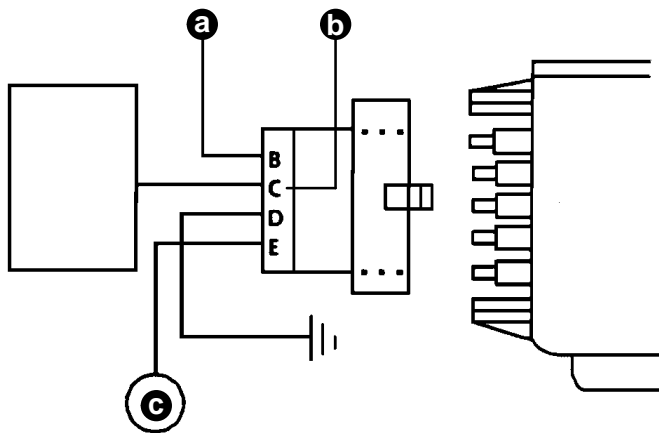

Knock Sensor System

- a - Positive Lead (12 Volts)
- b - 8-10 Volts To Knock Sensor
- c - Knock Sensor

It is extremely important that the correct knock module and sensor be used for the engine application. Using an incorrect knock module or sensor will result in unrecognized spark knock and engine damage. The Knock module terminal B is powered by 12 volts from the ignition switch. If the 12 volt power source is not present, the knock module cannot send an 8-10 volt signal to the ignition control module and a false constant spark retard will result.

Terminal "E" of the knock module is the signal line from the knock sensor. If this circuit opens or shorts to ground, the knock module will never remove the 8-10 volt signal from terminal "C" to and no spark retard will occur. The ground circuit for the knock module is connected to terminal "D". If the ground circuit opens, the knock module will not be able to remove the 8-10 volt signal and spark knock cannot be controlled.

IMPORTANT: If knock sensor wire is routed too close to secondary ignition wires, the Knock module may see the interference as a knock signal, resulting in false timing retard.

IMPORTANT: If there is abnormal mechanical engine noise (rattles or knocks), they may give a false knock retard signal. If fuel octane is too high or too low, a false signal can also be sent.

TESTING KNOCK MODULE AND SENSOR

NOTE: A digital volt-ohmmeter (DVOM) and an unpowered test light (low power test light - 300mA or less) are needed to conduct the following test.

⚠ WARNING

Avoid fire or explosion. Ensure that engine compartment is well ventilated and gasoline vapors are not present when performing electrical tests inside the engine compartment. Sparks generated by electrical tests could ignite gasoline vapors causing fire or explosion.

1. Start engine and warm it up to normal operating temperature.
2. Connect the positive (+) lead from the DVOM to the PURPLE/WHITE timing terminal that comes from the engine harness (see previous wiring diagram). Connect the negative (-) lead from the DVOM to a good engine ground (-). With the engine running, there should be 8-10 volts on this circuit. If voltage is not present, check to ensure that there is 12 volts to the knock module (PURPLE wire Terminal "B").
3. Advance the throttle to approximately 1500 RPM.
4. Disconnect the harness connector (BLUE wire) from the knock sensor. Connect the unpowered test light to a positive (+) 12 volt source. To simulate an AC voltage, rapidly tap the knock sensor harness terminal with the test light. If knock module and wiring is functioning properly, you should see a voltage drop on the DVOM. If a voltage drop is not seen, check the BLUE wire from the sensor to the knock module for a short or open circuit. If the circuit is functioning properly to this point, the knock sensor may not be functioning. Proceed to the following step.
5. Reconnect the knock sensor harness connector to the sensor.
6. While still watching the DVOM, lightly and rapidly tap on the engine block near the knock sensor with a small hammer. If the knock sensor is functioning properly, you should see the voltage decrease. If a voltage drop is not seen, the knock sensor is faulty.

INSTALLATION OF KNOCK SENSOR

IMPORTANT: If installing a new knock sensor, be sure to replace it with an identical part. Knock sensors are very sensitive and designed for each specific application.

IMPORTANT: It is very important that the knock sensor be torqued to the exact specification. Incorrect torquing will result in unsatisfactory performance. **DO NOT** use sealer on threads.

1. Install knock sensor in engine block. Torque to 12-16 lb. ft. (16.3-21.7 N·m).

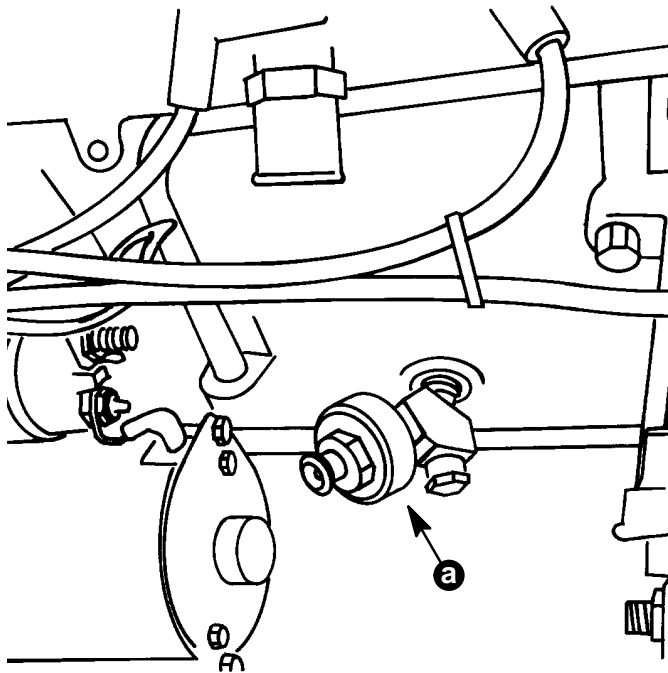

73756

a - Knock Sensor

2. Connect electrical connector to knock sensor.

Spark Plugs

1. Inspect each plug individually for badly worn electrodes, glazed, broken or blistered porcelain and replace where necessary.
2. Inspect each spark plug for make and heat range. All plugs must be the same make and number and heat range. Refer to "Specifications" for spark plug numbers.
3. Adjust spark plug gaps with a round feeler gauge. Refer to "Specifications" for proper spark plug gap.

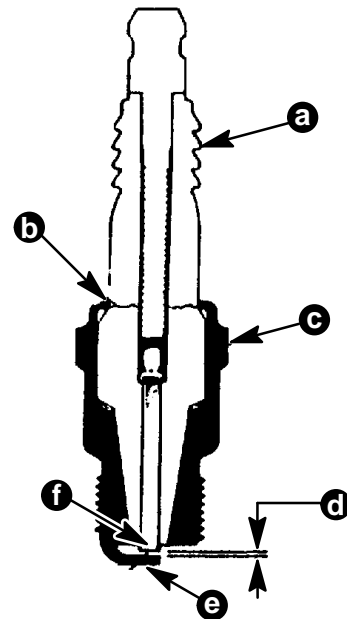

72734

- a - Porcelain Insulator
- b - Insulator Cracks Often At This Point
- c - Shell
- d - Proper Gap
- e - Side Electrode (Bend To Adjust Gap)
- f - Center Electrode (File When Adjusting Gap - DO NOT Bend)

4. Clean spark plug seating area. Do not use gaskets on taper seat plugs. Install spark plugs and torque to specifications. Where used, gasket must be fully compressed to complete heat transfer and provide a gas-tight seal in cylinder. For this reason, as well as the necessity of maintaining correct plug gap, correct torque is very important during installation.

IMPORTANT: Tapered seat spark plugs are not interchangeable with non-tapered (with gasket) spark plugs.

Spark Plug Wires

1. Inspect spark plugs for damage.
2. Check spark plugs for continuity using Multi-Meter / DVA (91-99750) or similar.
3. Replace any wires that are cracked, cut, or have damaged spark plug boots.
4. Replace any wires that do not show continuity from end to end.
5. Reinstall wires in proper order. Observe the following:

IMPORTANT: Proper positioning in spark plug wire supports is important to prevent cross-firing.

IMPORTANT: Before installing coil wire to coil, apply approximately 1/2 oz. of insulating compound around top of coil lead tower. Force nipple into coil and wipe off excess. Make sure boot does not “hydraulically back off” the distributor cap terminal.