



**MERCURY**  
**GO BOLDLY.™**

8M0237327 625 eng



**Operation  
and  
Maintenance  
Manual**

V10 350/400/425hp Verado, 400R

© 2025 Mercury Marine



Scan for service and support information



## Welcome

You have selected one of the finest marine power packages available. It incorporates numerous design features to ensure operating ease and durability. With proper care and maintenance, you will enjoy using this product for many boating seasons. To ensure maximum performance and carefree use, we ask that you thoroughly read this manual before operating the outboard.

The Operation and Maintenance Manual contains specific instructions for using and maintaining your product. Keep this manual with the product for reference whenever you are on the water. This manual should stay with the outboard engine, if it is sold.

Thank you for purchasing one of our products. We sincerely hope your boating will be pleasant.

Mercury Marine, Fond du Lac, Wisconsin, U.S.A.

## Read This Manual Thoroughly

**IMPORTANT: Your dealer can provide a demonstration of starting and operating procedures. If you do not understand any portion of this manual, contact your dealer.**

## Safety Alerts

Throughout this publication and on your power package, safety alerts labeled

WARNING and CAUTION (accompanied by the symbol ) , are used to alert you to special instructions concerning a particular service or operation that may be hazardous if performed incorrectly or carelessly. Observe these alerts carefully.

These safety alerts alone cannot eliminate the hazards that they signal. Strict compliance to these special instructions when performing the service, plus common sense operation, are major accident prevention measures.

### WARNING

**Indicates a hazardous situation which, if not avoided, could result in death or serious injury.**

### CAUTION

**Indicates a hazardous situation which, if not avoided, could result in minor or moderate injury.**

## Additional Alerts

Additional alerts provide information that requires special attention:

### NOTICE

**Indicates a situation which, if not avoided, could result in engine or major component failure.**

**IMPORTANT: Identifies information essential to the successful completion of the task.**

**NOTE:** Indicates information that helps in the understanding of a particular step or action.

## California Proposition 65

### California Proposition 65



WARNING: This product can expose you to chemicals including gasoline engine exhaust, which is known to the State of California to cause cancer and birth defects or other reproductive harm. For more information go to [www.P65Warnings.ca.gov](http://www.P65Warnings.ca.gov).

## Notice to Users of This Manual

**IMPORTANT: The operator (driver) is responsible for the correct and safe operation of the boat, the equipment aboard, and the safety of all occupants aboard. The operator is strongly encouraged to read this Operation and Maintenance Manual to thoroughly understand the operational instructions for the power package and all related accessories before the boat is used.**

Descriptions and specifications contained herein were in effect at the time this was approved for distribution. Mercury Marine, whose policies are based on continuous improvement, reserves the right to discontinue models at any time or to change specifications or designs without notice and without incurring obligation.

## Warranty Message

The product you have purchased comes with a **Mercury Marine Limited Warranty**. The terms of the warranty are set forth in the Warranty Manual, which can be accessed any time on the Mercury Marine website, at <http://www.mercurymarine.com/warranty-manual>. The Warranty Manual contains a description of what is covered, what is not covered, the duration of coverage, how to best obtain warranty coverage, **important disclaimers, limitations, and waivers**, and other related information. Please review this important information.

Mercury Marine products are designed and manufactured to comply with our own high quality standards, applicable industry standards and regulations, and certain emissions regulations. At Mercury Marine every engine is operated and tested before it is boxed for shipment to make sure that the product is ready for use. In addition, certain Mercury Marine products are tested in a controlled and monitored environment, for up to 10 hours of engine run time, in order to verify and make a record of compliance with applicable standards and regulations. All Mercury Marine product, sold as new, receives the applicable limited warranty coverage, whether the engine participated in one of the test programs described above or not.

This manual contains information required for the safe and proper operation, installation, and maintenance of the product. Use of the product not in accordance with any and all instructions for operation and maintenance outlined in this manual will be considered as improper, abnormal, abusive or non-acceptable use of the product and may result in the Mercury Marine Limited Warranty or legal guarantee (if and where applicable) being fully or partly void.

## **Copyright and Trademark Information**

**© MERCURY MARINE. All rights reserved. Reproduction in whole or in part without permission is prohibited.**

Alpha, Avator, Axius, Bravo One, Bravo Two, Bravo Three, Bravo Four S, Circle M with Waves Logo, GO BOLDLY, K-planes, Mariner, MerCathode, MerCruiser, Mercury, Mercury with Waves Logo, Mercury Marine, Mercury Precision Parts, Mercury Propellers, Mercury Racing, MotorGuide, OptiMax, Pro XS, Quicksilver, SeaCore, Skyhook, SmartCraft, Sport-Jet, Verado, VesselView, Zero Effort, Zeus, #1 On the Water and We're Driven to Win are registered trademarks of Brunswick Corporation. Mercury Product Protection is a registered service mark of Brunswick Corporation. All other marks are the property of their respective owners.



---

## Important Safety Information

---

Boater's Responsibilities.....	1
Boat Horsepower Capacity.....	1
Exhaust Emissions.....	1
Outboard Remote Control Models .....	3
Lanyard Stop Switch.....	4
Staying Safe Around the Outboard.....	7
Safe Operating Practices.....	7
Impact with Underwater Hazards.....	13

---

## General Information

---

Specifications.....	15
Component Identification.....	18
Gearcase Identification.....	19
Propeller Selection.....	19
Recording the Serial Number.....	20
Selecting Outboard Accessories.....	21

---

## Transporting

---

Aquatic Invasive Species (AIS).....	23
Trailing Boat/Outboard.....	24

---

## Fuel and Oil

---

Fuel Requirements.....	25
Fuel Additives.....	26
Fuel Demand Valve.....	26
Low Permeation Fuel Hose Requirement .....	26
Filling the Fuel System.....	27
Engine Oil Recommendations (Non-Racing Models).....	27
Engine Oil Recommendations—400R Models.....	27
Checking and Adding Engine Oil.....	28

---

## Digital Throttle and Shift Controls

---

Electronic Remote Control (ERC).....	33
Foot Throttle.....	43
Active Trim.....	45
Engine Synchronization (Multiple Engines).....	51
Helm Transfer.....	52
Quick Steer.....	54
Single-Lever Mode (Multiple Engines).....	54
Start/Stop All Engines.....	55
Throttle and Shift Operation with Three or Four Engines.....	56
Throttle-Only Mode.....	59

---

## Features

---

Adaptive Speed Control.....	61
Warning System.....	61
Power Trim and Tilt.....	63

---

## Operation

---

Engine Break-in Procedure.....	69
Important Daily Inspection Before Each Use .....	69
Prestarting Checklist.....	69
Starting the Engine.....	70
Gear Shifting.....	72
Stopping the Engine.....	73
Proper Outboard Tilt Positioning During Periods of Non-Use.....	73
Operating at High Elevations.....	74
Operating in Freezing Temperatures.....	74
Operating in Saltwater or Polluted Water.....	75
Operating in Shallow Water.....	75
Setting Trim Angle While Running Engine at Idle Speed.....	76
Ran Out of Fuel Condition—Priming the Fuel System.....	76

---

## Maintenance

---

EPA Emissions Regulations.....	79
Cleaning Care Recommendations.....	80
Use of Anti-fouling Bottom Paint.....	82
Top Cowl Removal and Installation.....	83
Inspection and Maintenance Schedule.....	84
Maintenance Schedule Decals.....	87
Battery and Electrical.....	90
Flushing the Cooling System.....	92
Corrosion Control Anodes.....	94
Engine Oil and Filter.....	95
Fuel System.....	101
Gearcase Lubricant.....	104
Checking Power Trim Fluid.....	107
Propeller Replacement—6.4 Gearcase.....	108
Propeller Replacement—5.44 Gearcase.....	111
Checking Power Steering Fluid (if Equipped).....	113
Transom Tightness Inspection.....	114
Dealer Service Items.....	115

---

## Storage

---

Storage Preparation.....	117
Protecting the Fuel System.....	117
Protecting External Outboard Components.....	117
Protecting Internal Engine Components.....	118
Engine Fluids.....	118
Positioning Outboard for Storage.....	118
Battery Storage.....	119

---

## Troubleshooting

---

DTS Wiring System.....	121
Effects of Elevation and Weather on Performance.....	121
Fuses.....	122
Starter Motor Will Not Crank the Engine.....	125
Engine Will Not Start.....	125
Engine Starts But Will Not Shift Into Gear.....	125
Engine Runs Erratically.....	125
Performance Loss.....	126
Cranking Battery Will Not Hold Charge.....	126

---

## Owner Service Assistance

---

Identification Records.....	127
Service Assistance.....	127
Ordering Literature.....	129

---

## Maintenance Log

---

Maintenance Log.....	131
----------------------	-----

# IMPORTANT SAFETY INFORMATION

## Boater's Responsibilities

The operator (driver) is at all times responsible for the correct and safe operation of the boat and the safety of its occupants and the general public. Each operator should read and understand this entire manual before operating the outboard.

At least one additional person onboard should be instructed in the basics of starting and operating the outboard and boat handling, in case the driver is unable to operate the boat.

The operator may be subject to local boating license requirements, which may vary according to boating location.

## Boat Horsepower Capacity

### **⚠ WARNING**

**Exceeding the boat's maximum horsepower rating can cause serious injury or death. Overpowering the boat can affect boat control and flotation characteristics or break the transom. Do not install an engine that exceeds the boat's maximum power rating.**

Most boats have a capacity plate to indicate the maximum power and boat load, as determined by the manufacturer and based on federal guidelines and applicable regulations. Never exceed these maximums.

U.S. COAST GUARD CAPACITY	
MAXIMUM HORSEPOWER	XXX
MAXIMUM PERSON CAPACITY (POUNDS)	XXX
MAXIMUM WEIGHT CAPACITY	XXX

26777

For clarification of horsepower or loading restrictions, contact the boat dealer or the boat manufacturer.

## Exhaust Emissions

### **⚠ WARNING**

**Inhaling engine exhaust gases can result in carbon monoxide poisoning, which can lead to unconsciousness, brain damage, or death. Avoid exposure to carbon monoxide.**

**Stay clear from exhaust areas when engine is running. Keep the boat well-ventilated while at rest or underway.**

# IMPORTANT SAFETY INFORMATION

## Be Alert to Carbon Monoxide Poisoning

Carbon monoxide (CO) is a deadly gas that is present in the exhaust fumes of all internal combustion engines, including the engines that propel boats and the generators that power boat accessories. By itself, CO is odorless, colorless, and tasteless, but whenever engine exhaust can be tasted or smelled, CO is being inhaled.



Early symptoms of carbon monoxide poisoning—which are similar to the symptoms of seasickness and intoxication—include headache, dizziness, drowsiness, and nausea.

Boats with enclosed cabins should have one or more CO sensors installed.

## Stay Clear of Exhaust Areas

Avoid areas of concentrated engine exhaust gases. When engines are running, keep swimmers away from the boat, and do not sit, lie, or stand on swim platforms or boarding ladders. While underway, do not allow anyone to be positioned immediately behind the boat (platform dragging, teak/body surfing). This practice not only poses the risk of extreme physical harm, but also places that person in an area of high engine exhaust concentration.

## Good Ventilation

Ventilate the passenger area by opening side curtains or forward hatches.

The following image shows an example of desired air flow through the boat.

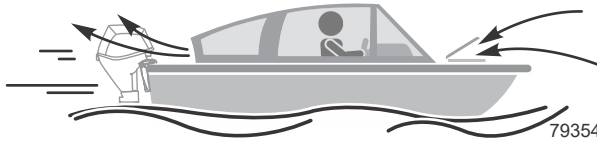

# IMPORTANT SAFETY INFORMATION

## Poor Ventilation

- **Boat in Motion:** Under certain running or wind conditions, permanently enclosed or canvas enclosed cabins or cockpits with insufficient ventilation may draw in carbon monoxide. The following shows examples of poor ventilation while the boat is moving.

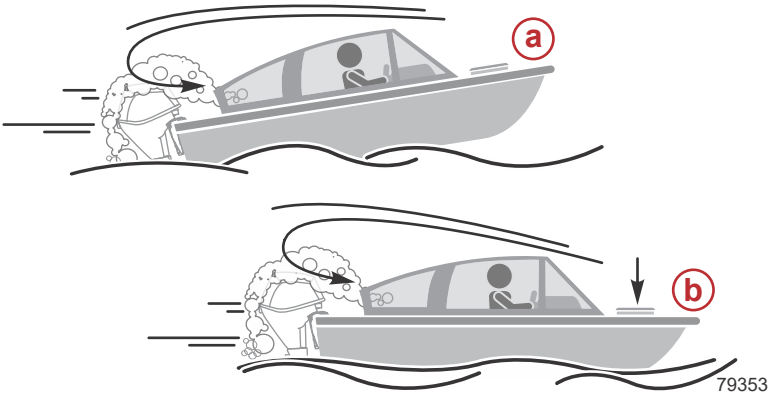

- **a -** Operating the boat with the trim angle of the bow too high
- **b -** Operating the boat with no forward hatches open
- **Stationary Boat:** Although the occurrence is rare, on a calm day, persons in an open area of a stationary boat that contains, or is near, a running engine may be exposed to a hazardous level of carbon monoxide. The following shows examples of poor ventilation while the boat is stationary.

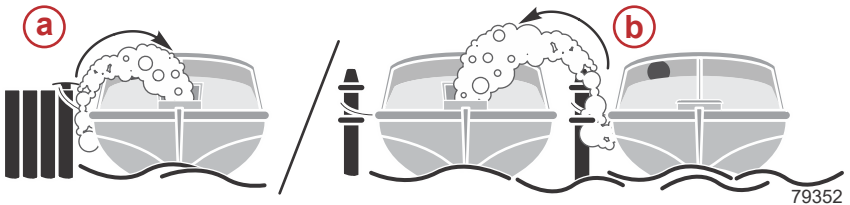

- **a -** Operating the engine when the boat is moored in a confined space
- **b -** Mooring close to another boat that has its engine operating

## Outboard Remote Control Models

The outboard must be equipped with a Mercury remote control designed for Digital Throttle and Shift (DTS). Start-in-gear protection is provided by the remote control system.

# IMPORTANT SAFETY INFORMATION

## Lanyard Stop Switch

The purpose of a lanyard stop switch is to turn off the engine when the operator moves far enough away from the operator's position (as in accidental ejection from the operator's position) to activate the switch. Tiller handle outboards and some remote control units are equipped with a lanyard stop switch. A lanyard stop switch can be installed as an accessory - generally on the dashboard or side adjacent to the operator's position.

A decal near the lanyard stop switch provides a visual reminder for the operator to attach the lanyard to their personal flotation device (PFD) or wrist.

**IMPORTANT: Do not add length to the lanyard cord beyond the original length. Any length extension of the original lanyard cord can result in propeller strike injuries including death, if the operator falls overboard.**

The lanyard cord is usually 122–152 cm (4–5 feet) in length when stretched out, with an element on one end that inserts into the switch and a clip on the other end that attaches to the operator's PFD or wrist. The lanyard cord is coiled to prevent entanglement with nearby objects. The cord's extended length minimizes accidental activation should the operator choose to move around in an area close to the normal operator's position. If a shorter lanyard is desired, wrap the lanyard around the operator's wrist or leg, or tie a knot in the lanyard.

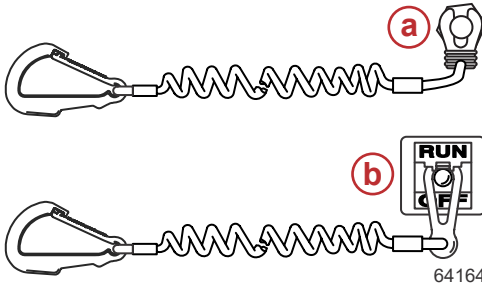

### Lanyard stop switch and cord examples

- a** - Button style lanyard switch
- b** - Toggle style lanyard switch

64164

# IMPORTANT SAFETY INFORMATION

## Lanyard Wrist Strap

A wrist strap makes it convenient to attach the lanyard to the operator's wrist. The strap encircles the operator's wrist, and the lanyard clip attaches to the strap, as shown. Adjust the diameter of the strap so that it cannot slip off the wrist during use.

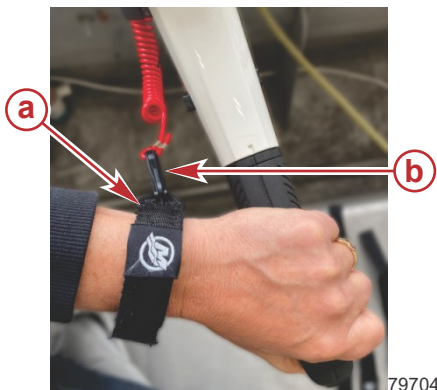

- a** - Wrist strap
- b** - Lanyard clip

The wrist strap is standard equipment for all tiller handle outboard models. It is recommended optional equipment for all other models. The wrist strap is available in both Mercury Marine and Quicksilver branding.



79705

## Lanyard Stop Switch and Safe Operation

### **⚠ WARNING**

**If the operator falls out of the boat, stop the engine immediately to reduce the possibility of serious injury or death from being struck by the boat. Always properly connect the operator to the stop switch using a lanyard.**

**IMPORTANT: Instruct at least one other boat occupant on proper starting and operating procedures, should they be required to operate the boat in an emergency.**

Activation of the lanyard stop switch will stop the engine immediately. However, a boat will continue to coast for some distance depending upon the velocity and degree of any turn at shutdown. While the boat is coasting, it can cause injury to anyone in the boat's path as seriously as it would when under power.

# IMPORTANT SAFETY INFORMATION

The lanyard stop switch stops the engine whenever the operator moves far enough away from the operator's position to activate the switch. This occurs if:

- The operator accidentally falls overboard, or
- The operator moves within the boat away from the operator's position.

Falling overboard and accidental ejections are more likely to occur in certain types of boats such as:

- Low-sided inflatables
- Bass boats
- High performance boats
- Light, sensitive-handling fishing boats operated by a hand tiller

Falling overboard and accidental ejections are also likely to occur as a result of poor operating practices such as:

- Sitting on the back of the seat or gunwale at planing speeds
- Standing at planing speeds
- Sitting on elevated fishing boat decks
- Riding in forward seating (such as in a bow rider) at planing speeds in rough water
- Operating at planing speeds in shallow or obstacle filled waters
- Releasing a steering wheel or tiller handle that is pulling in one direction
- Drinking alcohol or consuming drugs
- Performing high-speed boat maneuvers

Accidental or unintended activation of the switch during normal operation is also a possibility. This could cause any, or all, of the following potentially hazardous situations:

- Occupants could be thrown forward due to unexpected loss of forward motion - a particular concern for passengers in the front of the boat who could be ejected over the bow and possibly struck by the boat.
- Loss of power and directional control in heavy seas, strong current, or high winds.
- Loss of control when docking.

To avoid accidental switch activation, the operator should always be aware of their position in relation to the lanyard stop switch and should:

- Never move away from the operating position while the boat is in motion.
- Never move away from the operating position while the boat is stationary without first disconnecting the lanyard from their person.

# IMPORTANT SAFETY INFORMATION

## Keep the Lanyard Stop Switch and Lanyard Cord in Good Operating Condition

Before each use, check to ensure that the lanyard stop switch works properly. Start the engine and stop it by pulling the lanyard cord. If the engine does not stop, have the switch repaired before operating the boat.

Before each use, visually inspect the lanyard cord to ensure it is in good working condition and that there are no breaks, cuts, or wear to the cord. Check that the clips on the ends of the cord are in good condition. Replace any damaged or worn lanyard cords.

## Staying Safe Around the Outboard

### **⚠ CAUTION**

**Prevent injuries from slips and falls while at or near the back of the boat. Surfaces may be uneven or slippery. Keep clear and avoid using any part of the outboard engine as a stabilizer for balance support or as a handhold, foothold, or ladder.**

Even when it is not operating, an outboard engine can present hazards to people in the boat and in the water.

- Always ensure that all passengers stay clear of the engine, whether the boat is in motion or stationary and whether the engine is operating or is shut off.
- Never use the outboard as a seat.
- Never use any portion of the outboard as a step.
- Never climb on any part of the outboard or use any portion of it as a handhold.

## Safe Operating Practices

### Passenger Safety - Pontoon Boats and Deck Boats

Whenever the boat is in motion, observe the location of all passengers. Do not allow any passengers to stand or use seats other than those designated for traveling faster than idle speed. A sudden reduction in boat speed, such as plunging into a large wave or wake, a sudden throttle reduction, or a sharp change of boat direction, could throw them over the front of the boat. Falling over the front of the boat between the two pontoons will position them to be run over by the outboard.

# IMPORTANT SAFETY INFORMATION

## Boats with an Open Front Deck

### **⚠ WARNING**

**Sitting or standing in an area of the boat not designed for passengers at speeds above idle can cause serious injury or death. Stay back from the front end of deck boats or raised platforms and remain seated while the boat is in motion.**

No one should ever be on the deck in front of the fence while the boat is in motion. Keep all passengers behind the front fence or enclosure.

Persons on the front deck could easily be thrown overboard or persons dangling their feet over the front edge could get their legs caught by a wave and pulled into the water.

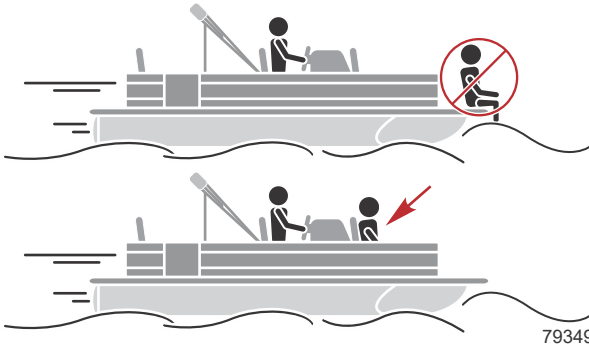

## Boats with Front-Mounted, Raised Pedestal Fishing Seats

Elevated fishing seats are not intended for use when the boat is traveling faster than idle or trolling speed. Sit only in seats designated for traveling at faster speeds.

Any unexpected, sudden reduction in boat speed could result in the elevated passenger falling over the front of the boat.

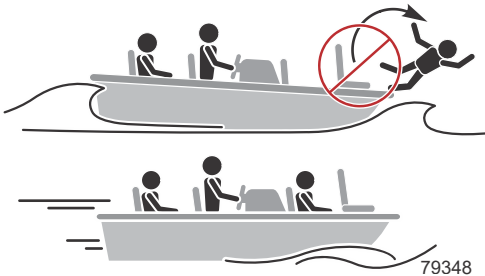

# IMPORTANT SAFETY INFORMATION

## Protecting People in the Water

### While the Boat is in Operation

People in the water cannot take quick action to avoid a boat heading in their direction.



Approach slowly and exercise extreme caution when boating in areas where people may be in the water.

When a boat is moving and the gear shift is in neutral, there is sufficient force by the water on the propeller to cause the propeller to rotate. This neutral propeller rotation can cause serious injury.

### While the Boat is Stationary

#### **⚠ WARNING**

**A spinning propeller, a moving boat, or any solid device attached to the boat can cause serious injury or death to swimmers. Stop the engine immediately whenever anyone in the water is near the boat.**

Shift into neutral and shut down the engine before allowing people in the water near the boat.

## Safe Boating Recommendations

To safely enjoy the waterways, boat operators must be familiar with local and all other governmental boating regulations and restrictions. Boaters should also consider the following suggestions.

- **Know and obey all nautical rules and laws of the waterways.**
  - All powerboat operators are advised to complete a boating safety course. In the U.S., the U.S. Coast Guard Auxiliary, the Power Squadron, the Red Cross, and the state or provincial boating law enforcement agency provide courses. For more information, visit the Boat U.S. Foundation website at <https://boatus.org/>.
  - Some locations (states, territories, etc.) *require* a boating license or certificate. Always confirm licensing and certification requirements prior to boating in a new location.
- **Perform safety checks and required maintenance.** Follow a regular schedule and ensure that all repairs are properly made.

# IMPORTANT SAFETY INFORMATION

- **Check onboard safety equipment.** Regulating bodies in most areas *require* specific safety equipment on every powered boat. Even if not required, consider carrying the following on board, and always check the condition before each outing:
  - Approved fire extinguishers
  - Paddle or oar
  - Two-way radio
  - Weather radio
  - Compass and map or chart of the area
  - Signal devices: flashlight, rockets or flares, flag, and whistle or horn
  - Drinking water
  - First aid kit and instructions
  - Waterproof storage containers
  - Anchor and extra anchor line
  - Spare operating equipment, batteries, bulbs, and fuses
  - Manual bilge pump and extra drain plugs
  - Tools necessary for minor repairs
- **Watch for signs of weather change and avoid foul weather and rough-sea boating.**
- **Tell someone of the boating plans, including the expected route and estimated time of return.**
- **Passenger boarding:** Stop the engine whenever passengers are boarding, unloading, or are near the back (stern) of the boat. Shifting the drive unit into neutral is not sufficient.
- **Use personal flotation devices (PFDs).**
  - U.S. federal law *requires* that there be a U.S. Coast Guard-approved life jacket (personal flotation device), correctly sized and readily accessible for every person onboard, plus a type 4 throwable cushion or ring. It is strongly advised that everyone wear a life jacket at all times while in the boat.
  - U.S. federal law *requires* children 13 years of age and younger to wear a U.S. Coast Guard-approved personal flotation device while the boat is underway.
  - Use of personal flotation devices may be *mandatory* in areas outside of the U.S. Always check local laws and regulations before embarking.
  - Inspect the condition of all PFDs prior to embarking.
- **Prepare other boat operators.** Instruct at least one person onboard on the basics of starting and operating the engine and boat handling in case the driver becomes disabled or falls overboard.

# IMPORTANT SAFETY INFORMATION

- **Do not overload the boat.** Most boats are rated and certified for maximum load (weight) capacities (refer to the boat's capacity plate). Know the boat's operating and loading limitations. Know if the boat will float if it is full of water. When in doubt, contact a Mercury Marine Authorized Dealer or the boat manufacturer.
- **Ensure that everyone in the boat is properly seated.** Do not allow anyone to sit or ride on any part of the boat that was not intended for such use. This includes:
  - Backs of seats
  - Gunwales
  - Transom
  - Bow
  - Decks
  - Raised fishing seats
  - Any rotating fishing seat

Passengers should not sit or ride anywhere that sudden unexpected acceleration, sudden stopping, unexpected loss of boat control, or sudden boat movement could cause them to be thrown overboard or into the boat. Ensure that all passengers have a proper seat and are in it before any boat movement.

- **Never operate a boat while under the influence of alcohol or drugs. It is the law.** Alcohol or drugs can impair human judgment and greatly reduce the ability to react quickly.
- **Know the boating area and avoid hazardous locations.**
- **Be alert.** The operator of the boat is responsible by law to maintain a proper lookout by sight and hearing. The operator must have an unobstructed view, particularly to the front. No passengers, load, or fishing seats should block the operator's view when the boat is above idle or planing transition speed. Watch out for others, the water, and the wake.
- **Never drive the boat directly behind a water-skier.** A boat traveling at 40 km/h (25 mph) will overtake a fallen skier who is 61 m (200 ft) in front of the boat in five seconds.
- **Observe safe practices for using the boat for skiing, wake-boarding, or similar activity.**
  - A minimum of two persons should be onboard the boat whenever a skier is in the water: one to drive the boat and one to act as a spotter (facing the skier at all times).
  - Always keep a fallen or down skier on the operator's side of the boat while returning to attend to the skier. The operator should always have the down skier in sight and never back up to the skier or anyone in the water.

# IMPORTANT SAFETY INFORMATION

- Some U.S. states and Canadian provinces require a "skier down" flag, have restrictions on spotter age, have rearview mirror requirements, and so forth. Know and obey all federal, state (provincial), and local laws and regulations.
- **Report accidents.**
  - In the U.S., boat operators are *required* by law to file a boating accident report with their state boating law enforcement agency when their boat is involved in certain boating accidents. A boating accident must be reported if:
    - i. There is loss of life or probable loss of life.
    - ii. There is personal injury requiring medical treatment beyond first aid.
    - iii. There is damage to boats or other property where the damage value exceeds \$2,000.00 (lower amounts in some states and territories).
    - iv. There is complete loss of the boat.Seek further assistance from local law enforcement.
  - Accident reporting requirements may vary in areas outside the U.S.

## Wave and Wake Jumping

### **⚠ WARNING**

**Wave or wake jumping can cause serious injury or death from occupants being thrown within or out of the boat. Avoid wave or wake jumping whenever possible.**

Operating recreational boats over waves and wake is a natural part of boating. However, when this activity is done with sufficient speed to force the boat hull partially or completely out of the water, certain hazards arise, particularly when the boat re-enters the water.



The primary concern is the boat changing direction while in the midst of the jump. In such case, the landing may cause the boat to spin or veer violently in a new direction. Such a sharp change in direction can cause occupants to be thrown out of their seats, or out of the boat.

## IMPORTANT SAFETY INFORMATION

There is another less common hazardous result from allowing a boat to launch off a wave or wake. If the bow of the boat pitches down far enough while airborne, upon water contact it may penetrate under the water surface and submarine for an instant. This will bring the boat to a nearly instantaneous stop and can send the occupants flying forward. The boat may also steer sharply to one side.

### Impact with Underwater Hazards

#### **⚠ WARNING**

**Operating a boat or engine with impact damage can result in product damage, serious injury, or death. If the vessel experiences any form of impact, have a Mercury Marine Authorized Dealer inspect and repair the vessel or power package.**

This outboard is equipped with a hydraulic trim and tilt system that also contains a shock absorbing feature. This feature helps the outboard withstand damage in the case of impact with an underwater object at low to moderate speeds. At higher speeds, the force of the impact may exceed the system's ability to absorb the energy of the impact and cause serious product damage.

No impact protection exists while in reverse. Use extreme caution when operating in reverse to avoid striking underwater objects.

Reduce speed and proceed with caution when driving a boat in shallow water areas or in areas where underwater obstacles may exist that could be struck by the outboard or the boat bottom. **The most significant action that can help reduce injury or impact damage from striking a floating or underwater object is to control the boat speed. Under these conditions, boat speed should be kept to the minimum planing speed, typically 24 to 40 km/h (15 to 25 mph).**

#### **⚠ WARNING**

**Avoid serious injury or death from all or part of an outboard or drive unit coming into the boat after striking a floating or underwater object. When operating in waters where objects may be at the surface or just under the surface of the water, reduce speed and keep a vigilant lookout.**

**Examples of objects that can cause engine damage are dredging pipes, bridge supports, wing dams, trees, stumps, and rocks.**



## IMPORTANT SAFETY INFORMATION

Striking a floating or underwater object could result in any of a number of situations. Some of these situations could yield the following:

- Part of the outboard or the entire outboard could break loose and fly into the boat.
- The boat could move suddenly in a new direction. A sharp change in direction can cause occupants to be thrown out of their seats or out of the boat.
- The boat's speed could rapidly reduce. This will cause occupants to be thrown forward or even out of the boat.
- The outboard or boat could sustain impact damage.

After striking a submerged object, stop the engine as soon as possible and inspect it for any broken or loose parts. If damage is present or suspected, the outboard should be taken to an authorized dealer for a thorough inspection and necessary repair.

The boat should also be checked for any hull fractures, transom fractures, or water leaks. If water leaks are discovered after an impact, immediately activate the bilge pump.

Operating a damaged outboard could cause additional damage to other parts of the outboard or could affect control of the boat. If continued running is necessary, do so at greatly reduced speeds.

# GENERAL INFORMATION

## Specifications

Parameter		Specification
Rated Power	350hp Verado	257 kW (350 hp)
	400hp Verado, 400R	294 kW (400 hp)
	425hp Verado	313 kW (425 hp)
Full throttle range	350hp, 400hp Verado	5800–6400 RPM
	400R, 425hp Verado	6000–6600 RPM
Idle speed in neutral gear*		650 RPM
Idle charge compensation**		650–775 RPM
Troll control limit		550–1000 RPM
Number of cylinders		10
Piston displacement		5.7 L (349 cid)
Spark plug	Recommended model	NGK LKAR7C-9
	Gap	0.9 mm (0.035 in.)
	Hex size	14 mm
Gearcase type	350hp, 400hp, 425hp Verado	163 mm (6.4 in.)
	350hp Verado, 400R	137 mm (5.44 in.) HD or Sport Master 137 mm (5.44 in.)
Gearcase capacity	163 mm (6.4 in.) Right-hand	1580 mL (53.4 fl oz)
	163 mm (6.4 in.) Left-hand	1380 mL (46.7 fl oz)
	Sport Master (SM) Right-hand, Left-hand	620 mL (21.0 fl oz)
	137 mm (5.44 in.) HD Right-hand, Left-hand	820 mL (27.7 fl oz)
Overall gear ratio—forward	163 mm (6.4 in.) Gearcase	2.08:1
	137 mm (5.44 in.) HD or SM gearcase (350hp Verado)	1.75:1
	137 mm (5.44 in.) HD or SM gearcase (400R)	1.6:1
Recommended fuel		Refer to <b>Fuel and Oil</b>
Recommended oil		Refer to <b>Fuel and Oil</b>
Engine oil capacity with oil filter replacement		9.5 L (10.0 US qt)

# GENERAL INFORMATION

Parameter	Specification
Required battery type	12-volt absorbed glass mat (AGM) battery
Battery rating	Refer to <b>Engine Battery Specifications</b>

\*Engine at normal operating temperature.

\*\*The idle speed may automatically increase up to 775 RPM to compensate for a low battery charge condition. The increased idle speed will charge the battery at a higher rate. Activating the troll control (optional accessory) will override this feature.

## Engine Battery Specifications

**IMPORTANT: This engine requires a 12-volt absorbed glass mat (AGM) or Lithium-Ion marine cranking battery that meets the minimum ratings.**

- Do not use flooded (wet cell) lead acid batteries or gel cell lead acid batteries for cranking marine engines.
- Lithium-Ion batteries must meet the requirements in **Lithium-Ion Cranking Battery Requirements**
- Each engine must be equipped with its own cranking battery.
- Do not use an engine cranking battery that does not meet the specified ratings. If a battery that does not meet the ratings is used, the electrical system may perform poorly.
- If the boat application requires additional battery loads for boat accessories or marine electronics, install an auxiliary battery or batteries.

Required 12-volt Absorbed Glass Mat (AGM) Battery Ratings		
USA (SAE) cranking battery rating:	With dedicated house battery	1000 minimum marine cranking amps (MCA) with a minimum reserve capacity of 100 minutes RC25 rating
	Cranking battery only	1000 minimum marine cranking amps (MCA) with a minimum reserve capacity of 135 minutes RC25 rating
International (EN) cranking battery rating:		800 minimum cold cranking amps (CCA) with a minimum of 65-amp hours (Ah)

**NOTE:** Battery manufacturers may rate and test their batteries to different standards. MCA, CCA, Ah, and reserve capacity (RC) are the ratings recognized by Mercury Marine. Manufacturers that use standards different than these, such as equivalent MCA, do not meet Mercury Marine battery requirements.

# GENERAL INFORMATION

## Battery Installation Requirements

### **⚠ WARNING**

**Failure to properly secure the battery leads can result in a loss of power to the Digital Throttle and Shift (DTS) system, leading to serious injury or death due to loss of boat control. Secure the battery leads to the battery posts with hex nuts to avoid loose connections.**

**IMPORTANT: Boating industry standards (BIA, ABYC, etc.), federal standards, and Coast Guard regulations must be adhered to when installing the battery. Ensure that the battery cable installation meets the pull test requirements and that the positive battery terminal is properly insulated in accordance with regulations.**

**It is recommended (required in some states) that the battery be installed in an enclosed case. Refer to local regulations.**

<b>Description</b>	<b>Nm</b>	<b>lb-in.</b>	<b>lb-ft</b>
Battery hex nuts	13.5	120	–

## Lithium-Ion Cranking Battery Requirements

<b>Description</b>	<b>Specification</b>
Chemistry/format	Lithium iron phosphate designed for marine cranking use
Minimum cranking amps	800 A for 8 second minimum at 20 °F (-7 °C)
Peak charge acceptance	165 A 20-130 °F (-7-55 °C) for one minute
Max charge/alternator size	150 A 20-130 °F (-7-55 °C)
Max charge voltage/alternator output	14.8 V
Reserve Capacity (RC25 at 80 °F)	135 minutes
Ingress Protection (IP) rating	IP67 or greater

# GENERAL INFORMATION

## Component Identification

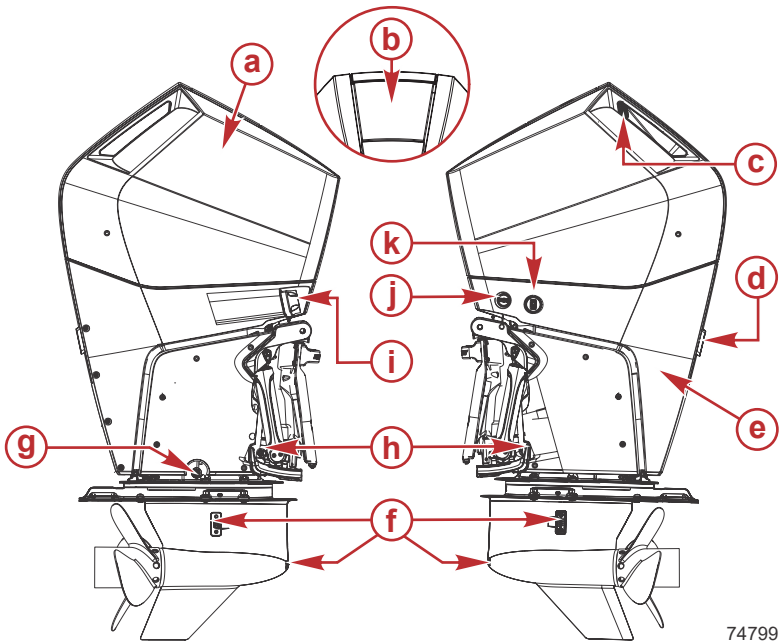

74799

- a** - Top cowl
- b** - Service access door
- c** - Service access door release button
- d** - Exhaust relief
- e** - Lower cowl
- f** - Cooling water intake holes
- g** - Engine oil drain
- h** - Manual tilt release (on trim cylinders)
- i** - Rigging ingress
- j** - Engine flush port
- k** - Auxiliary tilt switch

# GENERAL INFORMATION

## Gearcase Identification

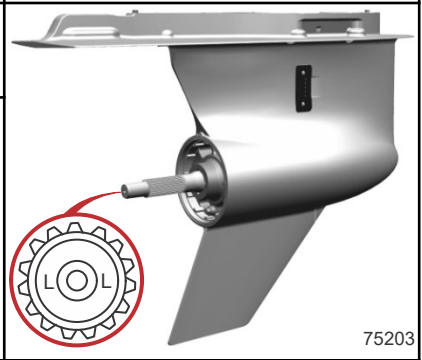
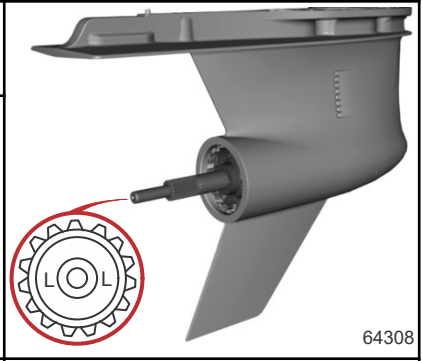
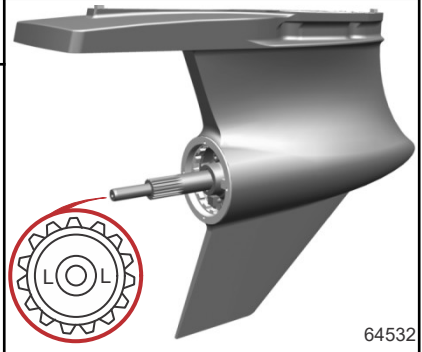
Diameter or Type	Identification Features	Illustration
163 mm (6.4 in.)	Water intake—nine per side, six torpedo low water	 <p>75203</p>
	Left-hand rotation gearcase—LL stamped on the end of propeller shaft	
137 mm (5.4 in.)	Water intake—eight per side, eight torpedo low water	 <p>64308</p>
	Left-hand rotation gearcase—LL stamped on the end of propeller shaft	
Sport Master	Water intake—three torpedo low water	 <p>64532</p>
	Left-hand rotation gearcase—LL stamped on the end of propeller shaft	

## Propeller Selection

**IMPORTANT: To ensure proper fit and performance, use only Mercury or Quicksilver branded propellers and mounting hardware.**

# GENERAL INFORMATION

The propeller is one of the most important components in the propulsion system. An improper propeller choice can significantly affect boat performance and could result in damage to the outboard engine. Damage to an engine resulting from the use of an improper propeller is not covered by the Mercury Marine Limited Warranty.

## About Propellers

Propellers are designated by the diameter, pitch (the distance the propeller travels through water in a single rotation), number of blades (three and four blade propellers are most common), and material (e.g., aluminum or stainless steel). The diameter and pitch are stamped (cast) into the side or the end of the propeller hub. The first number represents the diameter of the propeller and the second number represents the pitch. For example, 14x19 indicates a propeller with a 14 inch diameter and 19 inches of pitch.

Mercury Marine offers a full selection of aluminum and stainless steel propellers specifically designed for each outboard model. For information about Mercury Marine's line of propellers, visit <https://www.mercurymarine.com/us/en/propellers>.

## Original Equipment Propellers

In general, the original equipment propeller will be the best-suited propeller for a given engine.

- Propellers installed by boat builders (OEMs) are selected for each particular boat hull and engine combination. OEMs have the highest level of knowledge of how hull design affects propeller selection.
- Propellers installed at the boat dealer are also selected according to boat hull and engine combination. Dealers will have knowledge of propeller selection criteria not typically held by the consumer.
- A damaged propeller should always be replaced with the same model propeller.

## Upgrading a Propeller

Customers considering upgrading their propeller for better performance are advised to contact a Mercury Marine Authorized dealer, who will be familiar with a variety of boat hull and engine applications.

## Required Propellers

Some engines require the use of a particular propeller and a particular propeller hub. Such requirements may be listed in **General Information - Specifications**. Be aware that any published propeller requirement is subject to change without notice. It is always best to consult a Mercury Marine Authorized dealer before purchasing a new propeller.

## Recording the Serial Number

Record the serial number and model number for future reference. An **Identification Records** table is available for this purpose, at the back of this manual.

# GENERAL INFORMATION

A decal containing serial number and model number is located on the outboard's transom bracket.

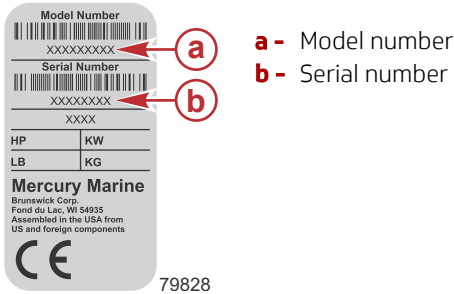

## Selecting Outboard Accessories

**IMPORTANT: Check with an authorized dealer before installing accessories. The misuse of approved accessories or the use of nonapproved accessories can damage the product.**

Genuine Mercury Precision or Quicksilver accessories have been specifically designed and tested for each Mercury Marine outboard. These accessories are available from Mercury Marine dealers.

Some accessories not manufactured or sold by Mercury Marine are not designed to be safely used with this outboard or outboard operating system and may void the limited warranty. Read the installation, operation and maintenance manuals for all selected accessories.

# GENERAL INFORMATION

Notes:

# TRANSPORTING

## Aquatic Invasive Species (AIS)



**STOP AQUATIC HITCHHIKERS!™**  
**Be A Good Steward. Clean. Drain. Dry.**

For additional information, visit [StopAquaticHitchhikers.org](http://StopAquaticHitchhikers.org).

### About AIS

AIS and their spread can detrimentally impact the boating experience and the future of the boating lifestyle. Reducing the spread of AIS has led to significant national efforts to inspect boats moving between water bodies or across state and federal boundaries and could lead to delayed or denied access if AIS are suspected or found on board.

AIS include plant life such as Eurasian watermilfoil and water hyacinth, and animals such as spiny water flea, quagga, and zebra mussels. AIS may vary in size from microscopic, to easily visible to the naked eye, and can live in residual water or mud. These species damage ecosystems and negatively impact fishing by depleting natural food resources, altering the water environment, and changing the structure of the ecosystem.

The impact of AIS has already resulted in the limiting of boating access to many waterways throughout North America, the closure of public boat ramps, and the reduction of availability for fishing and boating across the United States. Many federal, state, and local agencies have enacted laws and regulations for inspections, permits, launch availability, and water access for vessels entering public waterways.

Boats and associated equipment are major contributors to the spread of AIS. Boats that have come into contact with AIS can become a means of transportation through attachment and entrapment.

### Boat Cleaning and AIS

Water passes in and out of the space under the engine's lower cowls during normal operation of the boat. When flushing and cleaning the boat to control the spread of AIS, pay attention to this space by directing flushing water into the spaces under the lower cowl.

The engine cooling system can be flushed by operating the engine with the appropriate flushing attachment and introducing heated water to the engine.

### Region-Specific Information

For more information about the control of AIS in a specific region, please contact the local area wildlife conservation office or local governmental natural resources office.

# TRANSPORTING

## Trailing Boat/Outboard

If the boat trailer provides sufficient ground clearance, the outboard may be tilted down to the vertical operating position with no additional support required.

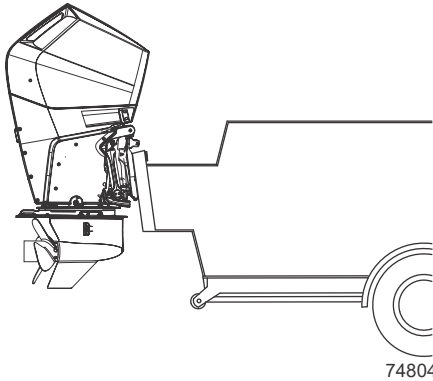

If additional ground clearance is required, the outboard should be tilted up and supported using the outboard's tilt support bracket in addition to using an accessory transom support device. Refer to **Features - Power Trim and Tilt**.

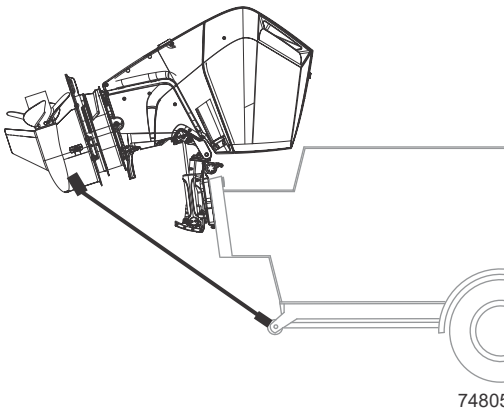

Additional clearance may be required for railroad crossings, driveways, and trailer bouncing. Contact a Mercury Marine authorized dealer for recommendations.

**IMPORTANT: Do not rely on the power trim/tilt system to maintain proper ground clearance for trailering. The power trim/tilt system is not intended to support the outboard for trailering.**

# FUEL AND OIL

## Fuel Requirements

**IMPORTANT: Use of improper gasoline can damage an engine. Engine damage resulting from the use of improper gasoline is considered misuse of the engine and will not be covered under the Limited Warranty or legal guarantee (if applicable).**

## Fuel Ratings

Mercury outboard engines will operate satisfactorily with any major brand of unleaded gasoline that meets the following specifications:

- **USA and Canada** - A posted pump octane rating of 87 (R+M)/2, minimum, for most models. Premium gasoline 91 (R+M)/2 octane is also acceptable for most models. **Do not** use leaded gasoline.
- **Outside USA and Canada** - A posted pump octane rating of 91 RON, minimum, for most models. Premium gasoline (95 RON) is also acceptable for all models. **Do not** use leaded gasoline.

## Using Reformulated (Oxygenated) Gasoline (USA Only)

Reformulated gasoline is required in certain areas of the USA and is acceptable for use in Mercury Marine engines. The only oxygenate currently in use in the USA is alcohol (ethanol, methanol, or butanol).

## Gasoline Containing Alcohol

### Bu16 Butanol Fuel Blends

Fuel blends of up to 16.1% butanol (Bu16) that meet the published Mercury Marine fuel rating requirements are an acceptable substitute for unleaded gasoline. Contact the boat manufacturer for specific recommendations on the boat's fuel system components (fuel tanks, fuel lines, and fittings).

### Methanol and Ethanol Fuel Blends

**IMPORTANT: The fuel system components on Mercury Marine engines will withstand up to 10% alcohol (methanol or ethanol) content in the gasoline. Some boat fuel systems may not be capable of withstanding the same percentage of alcohol. Contact the boat manufacturer for specific recommendations for boat-specific fuel system components (fuel tanks, fuel lines, and fittings).**

Be aware that gasoline containing methanol or ethanol may cause increased:

- Corrosion of metal parts
- Deterioration of rubber or plastic parts
- Fuel permeation through the rubber fuel lines
- Likelihood of phase separation (water and alcohol separating from the gasoline in the fuel tank)

# FUEL AND OIL

## ⚠ WARNING

**Fuel leakage is a fire or explosion hazard, which can cause serious injury or death. Periodically inspect all fuel system components for leaks, softening, hardening, swelling, or corrosion, particularly after storage. Any sign of leakage or deterioration requires replacement before further engine operation.**

**IMPORTANT:** When using gasoline that contains or might contain methanol or ethanol, increase the frequency of inspection for leaks and abnormalities.

**IMPORTANT:** When operating a Mercury Marine engine on gasoline containing methanol or ethanol, do not store the gasoline in the fuel tank for long periods. Cars normally consume these blended fuels before they can absorb enough moisture to cause trouble; boats often sit idle long enough for phase separation to take place. Internal corrosion may occur during storage if alcohol has washed protective oil films from internal components.

## Fuel Additives

To minimize carbon deposit buildup in the engine, add Mercury or Quicksilver Quickleen Engine and Fuel System Cleaner to the engine's fuel tank periodically throughout the boating season. Use the additive as directed on the container.

Description	Where Used	Part No.
Quickleen Engine & Fuel System Cleaner	Fuel tank	8M0047931

## Fuel Demand Valve

Some boat fuel systems incorporate a fuel demand valve between the fuel tank and the engine and others do not. This engine can be operated with or without a fuel demand valve.

The fuel demand valve has a manual release. The manual release can be used (pushed in) to open (bypass) the valve in case of a fuel blockage in the valve.

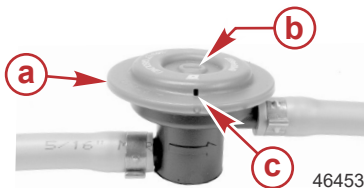

- a** - Fuel demand valve - installed in the fuel hose between the fuel tank and engine
- b** - Manual release
- c** - Vent/water drain holes

## Low Permeation Fuel Hose Requirement

Required for outboards manufactured for sale, sold, or offered for sale in the United States.

# FUEL AND OIL

- The Environmental Protection Agency (EPA) requires that any outboard manufactured after January 1, 2009, must use low permeation fuel hose for the primary fuel hose connecting the fuel tank to the outboard.
- Low permeation hose is USCG Type B1-15 or Type A1-15, defined as not exceeding 15 g/m<sup>2</sup>/24 h with CE 10 fuel at 23 °C as specified in SAE J 1527 - marine fuel hose.

## Filling the Fuel System

Turn the ignition key switch to the **RUN** position for approximately six seconds to operate the fuel pumps. Start and operate the engine to purge any remaining air from the fuel system. The engine may run rough while the air is purging through the fuel injectors. Purging air may take longer if the boat-mounted fuel filter is installed farther away from the engine. Increasing the throttle during engine operation will purge air from the fuel system more quickly.

## Engine Oil Recommendations (Non-Racing Models)

**IMPORTANT: Nondetergent oils, multiviscosity oils (other than Mercury or Quicksilver NMMA™ FC-W® certified oil or a major brand NMMA™ FC-W® certified oil), low quality oils, and oils that contain solid additives are not recommended.**

Mercury or Quicksilver NMMA™ FC-W® or NMMA™ FC-W® catalyst compatible certified SAE® 25W-40 Mineral Marine 4-Stroke Engine Oil or SAE® 25W-40 Synthetic Blend Marine 4-Stroke Engine Oil is recommended for general all-temperature use.

If the recommended Mercury or Quicksilver NMMA™ FC-W® certified oils are not available, a major outboard manufacturer's brand of NMMA™ FC-W® certified 4-Stroke outboard oil of similar viscosity may be used.

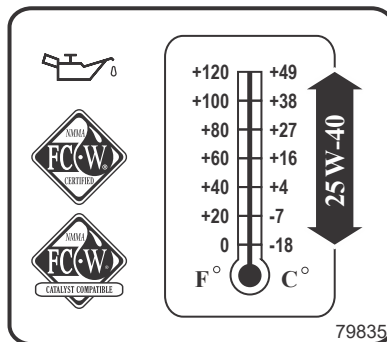

## Engine Oil Recommendations—400R Models

Mercury Racing 25W-50 NMMA™ certified FC-W® Marine Synthetic Blend Marine Engine Oil is the preferred choice for general all-temperature use.

# FUEL AND OIL

In lieu of the recommended oil, the following may be used (listed in order of preference):

- Mercury or Quicksilver NMMA™ FC-W® or NMMA™ FC-W® catalyst compatible certified SAE® 25W-40 Synthetic Blend Marine 4-Stroke Engine Oil.
- Mercury or Quicksilver NMMA™ FC-W® or NMMA™ FC-W® catalyst compatible certified SAE® 25W-40 Mineral Marine 4-Stroke Engine Oil.
- If the recommended Mercury Racing FC-W® certified oils are not available, a major outboard manufacturer's brand of NMMA™ FC-W® certified 4-Stroke outboard oil of the same viscosity may be used.

**IMPORTANT: Nondetergent oils, multiviscosity oils (other than Mercury or Quicksilver NMMA™ FC-W® certified oil or a major brand NMMA™ FC-W® certified oil), low quality oils, and oils that contain solid additives are not recommended.**

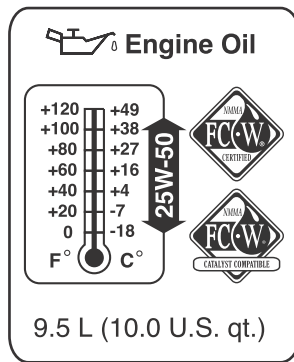

74817

## Checking and Adding Engine Oil

Follow the instructions below to check the engine oil level, and to add engine oil if required. Refer to **Maintenance - Changing Engine Oil and Filter** for additional details.

**NOTE:** Due to internal condensation, milky-colored oil may be observed during extended idle or low speed operation, especially in cold ambient conditions. Such milky oil/minor water accumulation is typically eliminated via 10–15 minutes of high speed or cruise speed operation, prior to overnight or extended shutdown.

## Electronic Oil Level Check

The engine oil level may be checked electronically while the engine is idling in neutral as follows:

1. Confirm the boat is not in shallow water and that there is no risk of bottoming out the propeller when trimming the engine.
2. Ensure that the joystick and Skyhook are not active, if equipped.

# FUEL AND OIL

3. In the VesselView display, navigate to **MERCURY** -> **MENU** -> **ENGINE DATA** -> **CHECK OIL LEVEL**.
4. Select **Check Oil Level**.



75289

5. Confirm the conditions on the OIL - LEVEL CHECK pop-up and select **Check oil level** to proceed.

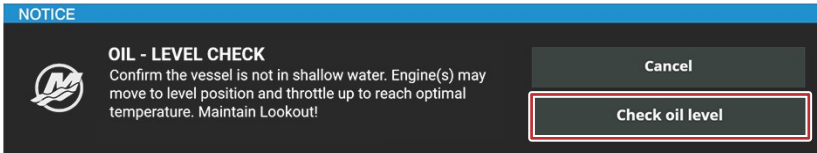

75290

- Do not trim the engine, shift out of neutral, activate the joystick/Skyhook, or increase engine speed while the oil level check is in process.
- The electronic control unit (ECU) will automatically trim the engine to the level position.
- The engine speed will slightly increase.

The oil level check may take up to one minute to complete and will indicate **Checking** until one of the following results appears on the display.

Overview	Port	Port Center	Starboard Center	Starboard
RPM	680	680	680	680
Oil Level	🔄 Checking	🔄 Checking	🔄 Checking	🔄 Checking
Engine Hours	98 Hr	102 Hr	101 Hr	99 Hr

75291

## Example: Oil level check in progress

Oil Level results:

- **High:** The oil level is high.
  - Change the engine oil and filter.
  - Refer to **Maintenance - Changing Engine Oil and Filter** for details.

# FUEL AND OIL

- **Good:** No action is required. The oil level is in a safe operating range.

Overview	Port	Port Center	Starboard Center	Starboard
RPM	1280	1280	1280	1280
Oil Level	✓ Good	✓ Good	✓ Good	✓ Good
Engine Hours	98 Hr	102 Hr	101 Hr	99 Hr

75292

## Example: Oil level check successfully completed

- **Low:** The oil level is low (bottom of dipstick crosshatch).
  - a. Turn the engine off.
  - b. Add 3.3 liter (3.5 US qt) of the recommended oil.
- **Critically Low:** The oil level is critically low (below dipstick crosshatch).
  - a. Turn the engine off.
  - b. Add 3.8 liter (4.0 US qt) of the recommended oil.
  - c. Use the dipstick to manually check the oil.
  - d. If necessary, add oil to reach the middle of the crosshatch/safe operating range. Refer to **Manual Oil Level Check**.
- **Unavailable:** Unable to complete the oil level check, likely due to trimming, shifting, increasing speed, or activating the joystick/Skyhook before the oil level measurement is complete.
  - a. Select **Dismiss** on the OIL - DATA UNAVAILABLE pop-up and repeat the measurement, but avoid trimming, shifting, increasing speed, or activating joystick/Skyhook.
  - b. If the result is still **Unavailable**, turn the engine off and use the dipstick to manually check the oil. Refer to **Manual Oil Level Check**.
  - c. Once the oil level is manually validated as OK, select **Oil Level is OK** on the OIL - DATA UNAVAILABLE pop-up.

### NOTICE



#### OIL - DATA UNAVAILABLE

Manually check and verify that oil levels are OK. Engine(s) must be off and at level position when checking engine oil. For additional information see owners manual.

Dismiss

Oil Level is OK

75293

**NOTE:** To ensure that the latest data is available, the Oil Level results will indicate **Data Expired** 10 minutes after completion of the **Electronic Oil Level Check**. Repeat the **Electronic Oil Level Check** procedure to obtain current results.

# FUEL AND OIL

## Manual Oil Level Check

### **IMPORTANT: Do not overfill.**

To avoid overfilling, the targeted level when adding oil should be 1/2 to 2/3 above the bottom of the dipstick crosshatch or ADD mark. The outboard must be in a vertical (not tilted) position when checking the engine oil. For accurate readings, check the oil only when the engine has not run for at least an hour.

The engine oil level may be checked manually via the oil dipstick as follows:

1. With the engine off, trim/tilt the outboard to the vertical (not tilted) position. Refer to **Features - Power Trim and Tilt**.
2. Press the service access door release button. The service access door will open.



- a** - Service access door release button
- b** - Service access door in open position

3. Remove the dipstick, wipe it clean, and install it fully into the dipstick tube.

# FUEL AND OIL

**NOTE:** A quick reference decal that lists the type of oil to use is located above the oil fill cap.

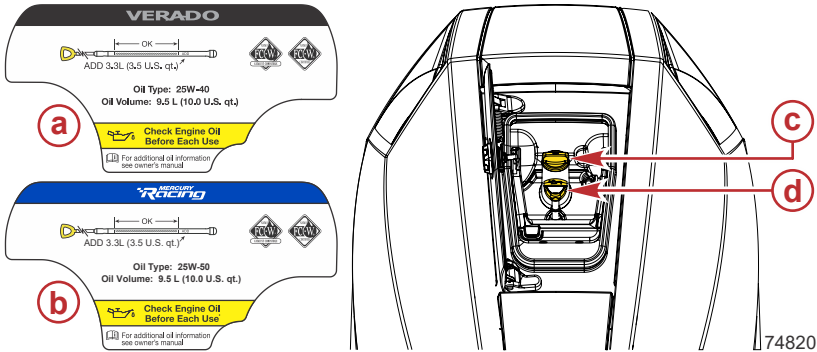

- a** - Verado Decal
- b** - Racing Decal
- c** - Oil fill cap
- d** - Dipstick

4. Remove the dipstick and observe the oil level. The oil level should be within the safe operating range.
5. If the oil level is below the ADD mark, or is not visible on the dipstick, remove the oil fill cap and add 3.3 liter (3.5 US qt) of the recommended oil.
6. Allow a few minutes for the oil to drain into the sump and insert the oil dipstick.
7. Remove the dipstick and observe the oil level. Add oil as necessary to reach the target oil level (1/2 to 2/3 above the bottom of the dipstick crosshatch or ADD mark).

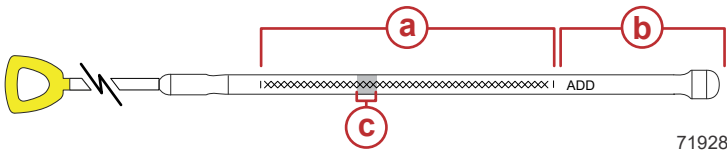

- a** - Safe operating range
- b** - Add 3.3 liter (3.5 US qt) of oil
- c** - Target oil level (1/2 to 2/3 above bottom of crosshatch)

8. Install the dipstick and oil fill cap hand-tight.
9. Close the service access door.

# DIGITAL THROTTLE AND SHIFT CONTROLS

## Electronic Remote Control (ERC)

Electric steering requires a Digital Throttle and Shift (DTS) electronic remote control (ERC). Because it is electronic, an ERC is capable of several features beyond the basic remote control functions of throttle and shift. These additional features are described in **Digital Throttle and Shift (DTS) Features**.

There are several DTS ERCs that can be used with electric steering, depending on the number of engines and the desired features. The following images show the current Mercury ERCs that will function with electric steering.



**Panel mount ERC - ES**



**Single-engine console ERC - ES**



**Dual-engine console ERC - no trim**



**Dual-engine console ERC - with trim**

# DIGITAL THROTTLE AND SHIFT CONTROLS



**Dual-engine console ERC -  
premier**



**Triple-engine console ERC -  
standard**



**Triple-engine console ERC -  
premier**



**Quad-engine console ERC -  
standard**



**Quad-engine console ERC -  
premier**



**Five or six-engine console ERC**

The basic styles of ERC are panel mount (single-engine only), single-handle console (single-engine only), and dual-handle console (two or more engines).

# DIGITAL THROTTLE AND SHIFT CONTROLS

## Panel Mount ERC

Panel mount ERCs control a single engine. There are several variations, but only one of these can be used with electric steering (ES).



Ref	Control/LED	Function
a	Neutral ( <b>N</b> ) LED	Illuminates when the engine is in the neutral gear position. The light flashes when the engine is in throttle-only mode.
b	Brightness (+ and -)	Increases and decreases the brightness settings for the lights on the ERC and Mercury helm components.
c	<b>THROTTLE ONLY</b>	Allows the boat operator to increase engine RPM without shifting into gear. Refer to <b>Throttle-Only Mode</b> .
d	<b>QUICK STEER</b> (if equipped)	Decreases the number of steering helm turns, lock-to-lock, for quicker response during docking. This feature also limits engine speed. Refer to <b>Quick Steer</b> .
e	<b>ACTIVE TRIM</b> (if equipped)	The <b>ACTIVE TRIM</b> button turns the Active Trim feature <b>ON</b> or <b>OFF</b> . Refer to <b>Active Trim</b> .
	Profile ▲ and ▼	Changes the selected Active Trim profile.
f	Active Trim LEDs ( <b>1, 2, 3, 4, 5</b> )	Indicates the currently selected Active Trim profile. <b>NOTE:</b> If the LED indicators are flashing, Active Trim is in setup mode.
	Lanyard stop switch (emergency stop)	In conjunction with the lanyard cord, shuts off the engine when the operator moves away from the ERC.

## DIGITAL THROTTLE AND SHIFT CONTROLS

Ref	Control/LED	Function
g	<b>START/STOP ENGINE</b>	Starts or stops the engine.
h	<b>UP ▲</b> and <b>DN ▼</b> — trim control	Raises and lowers the engine/drive for best efficiency, or for conditions such as shallow water or trailering. Some boats are equipped with separately-mounted trim controls.
i	Mechanical lock bar	Pressing the mechanical lock bar allows the engine to shift. The mechanical lock bar must always be pressed when moving the control handle out of the neutral position.

# DIGITAL THROTTLE AND SHIFT CONTROLS

## Single-Handle Console ERC

Single-handle console ERCs control a single engine. There are several variations, but only one of these can be used with electric steering (ES).



Ref	Control/LED	Function
a	Neutral ( <b>N</b> ) LED	Illuminates when the engine is in the neutral gear position. The light flashes when the engine is in throttle-only mode.
b	Brightness (+ and -)	Increases and decreases the brightness settings for the lights on the ERC and Mercury helm components.
c	<b>TRANSFER</b>	Allows boat control to be transferred to a different helm. (The LED will be ON at the active helm.) Refer to <b>Helm Transfer</b> .
d	<b>THROTTLE ONLY</b>	Allows the boat operator to increase engine RPM without shifting into gear. Refer to <b>Throttle-Only Mode</b> .
e	<b>QUICK STEER</b> (if equipped)	Decreases the number of steering helm turns, lock-to-lock, for quicker response during docking. This feature also limits engine speed. Refer to <b>Quick Steer</b> .
f	<b>ACTIVE TRIM</b> (if equipped)	The <b>ACTIVE TRIM</b> button turns the Active Trim feature <b>ON</b> or <b>OFF</b> . Refer to <b>Active Trim</b> .
	Profile ▲ and ▼	Changes the selected Active Trim profile.
	Active Trim LEDs (1, 2, 3, 4, 5)	Indicates the currently selected Active Trim profile. <b>NOTE:</b> If the LED indicators are flashing, Active Trim is in setup mode.
g	<b>START/STOP ENGINE</b>	Starts or stops the engine.

# DIGITAL THROTTLE AND SHIFT CONTROLS

<b>Ref</b>	<b>Control/LED</b>	<b>Function</b>
h	<b>UP ▲</b> and <b>DN ▼</b> — trim control	Raises and lowers the engine/drive for best efficiency, or for conditions such as shallow water or trailering. Some boats are equipped with separately-mounted trim controls.
i	Mechanical lock bar	Pressing the mechanical lock bar allows the engine to shift. The mechanical lock bar must always be pressed when moving the control handle out of the neutral position.

## Dual-Handle Console ERC

Dual-handle console ERCs control two, three, four, five, or six-engines. Dual-engine ERCs are available with or without integral trim switches.

# DIGITAL THROTTLE AND SHIFT CONTROLS

Premier ERCs have an integral, supplemental display, and are available for dual, triple, or quad-engine configurations. Refer to **ERC Supplemental Display** for details.



71950

**Dual-handle, quad-engine premier ERC shown, others similar**

Ref	Control/LED	Function
a	Neutral ( <b>N</b> ) LEDs (one on each handle)	Illuminate when the engine is in the neutral gear position. The lights flash when the engine is in throttle-only mode.
b	Brightness (+ and -)	Increases and decreases the brightness settings for the lights and display (if equipped) on the ERC and Mercury helm components.
c	<b>1 LEVER</b>	Enables the throttle and shift functions of all engines to be controlled by the port lever. Refer to <b>Single-Lever Mode</b> .
d	<b>TRANSFER</b>	Allows boat control to be transferred to a different helm. (The LED will be ON at the active helm.) Refer to <b>Helm Transfer</b> .
e	<b>THROTTLE ONLY</b>	Allows the boat operator to increase engine RPM without shifting into gear. Refer to <b>Throttle-Only Mode</b> .
f	<b>ACTIVE TRIM</b> (if equipped)	The <b>ACTIVE TRIM</b> button turns the Active Trim feature <b>ON</b> or <b>OFF</b> . Refer to <b>Active Trim</b> .
	Profile ▲ and ▼	Changes the selected Active Trim profile.
	Active Trim LEDs ( <b>1, 2, 3, 4, 5</b> )	Indicates the currently selected Active Trim profile. <b>NOTE:</b> If the LED indicators are flashing, Active Trim is in setup mode.

# DIGITAL THROTTLE AND SHIFT CONTROLS

Ref	Control/LED	Function
g	<b>START/STOP</b> individual engines	Press to start or stop the indicated engine, as equipped: <b>P</b> (port), <b>PC</b> (port center), <b>C</b> (center), <b>SC</b> (starboard center), <b>S</b> (starboard)
h	Display and display buttons (premier ERCs only)	Refer to <b>ERC Supplemental Display</b> for details.
i	<b>START/STOP - ALL ENGINES</b>	Starts or stops all engines. If some, but not all engines are running, pressing this button will stop all running engines. Refer to <b>Start/Stop All Engines</b> .
j	<b>UP ▲ and DN ▼</b> —trim control (if equipped)	Raises and lowers the engines/drives for best efficiency, or for conditions such as shallow water or trailering. <b>NOTE:</b> Trim switches for the individual engines are located on the front (bow side) of the ERC. Some boats are equipped with separately-mounted trim controls.

## ERC Supplemental Display

The ERC supplemental display will show the faults and the status of various features. Warnings for advanced features, such as Skyhook and Active Trim, will appear on the ERC supplemental display. Visit [mercurymarine.com](http://mercurymarine.com) for additional details.



- a** - Port engine gear indicator
- b** - Active Trim status
- c** - Starboard engine gear indicator
- d** - Display
- e** - ENTER button
- f** - Up/down selection buttons
- g** - Menu button

71958

## Electronic Remote Control (ERC) Operation

Operation of the shift and throttle is controlled by the movement of the control handle.

- Push the control handle forward from neutral to the first detent for forward gear.
- Continue pushing forward to increase speed.

# DIGITAL THROTTLE AND SHIFT CONTROLS

- Pull the control handle from the forward position to the neutral position to decrease speed and eventually stop.
- Pull the control handle back from neutral to the first detent for reverse gear.
- Continue pulling back to increase speed in reverse.

**NOTE:** On panel mount and single-handle console ERCs, press the mechanical lock bar when moving the control handle out of the neutral position.



## ERC Handle Friction and Detent Adjustment

The control handle friction adjustment screw can be used to increase or decrease the tension on the control handle. This will help prevent unwanted motion of the handle in rough water.

The detent adjustment screw can be used to increase or decrease the effort it takes to move the control handle out of the detent position.

**NOTE:** The control handle friction and detent adjustment screws may require periodic maintenance adjustment.

1. Remove the access cover from the front of the ERC to expose the adjustment screws.
2. Using a hex wrench, turn the desired screw clockwise to increase tension or counterclockwise to decrease tension.
3. Install the access cover after the desired tension is achieved.



**Panel mount ERC (ERC shown not installed, access cover removed)**

- a** - Handle friction adjustment screw
- b** - Detent adjustment screw

# DIGITAL THROTTLE AND SHIFT CONTROLS



## Single-handle console ERC

- a** - Access cover
- b** - Detent adjustment screw
- c** - Handle friction adjustment screw

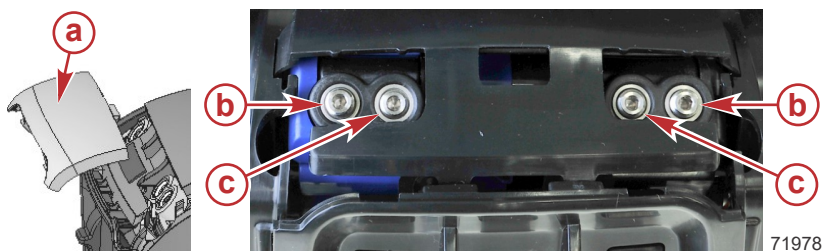

## Dual-handle console ERC

- a** - Access cover
- b** - Detent adjustment screws
- c** - Handle friction adjustment screws

# DIGITAL THROTTLE AND SHIFT CONTROLS

## Zero Effort Controls

Zero Effort controls allow the operator to control the shifting and throttle with separate control handles. Zero Effort controls are available in single, and multiple engine applications including shadow mode operation.



58266

## Foot Throttle

### Foot Throttle Requirements for Operation

Engine speed is controlled from idle to WOT by either the foot throttle or the remote control handle. Foot throttle operation requires the DTS system be set up with a dash-mounted switch that can turn the foot throttle control off or on. This will allow the boat operator to select the throttle operation through the electronic remote control assembly or through the foot control assembly.

# DIGITAL THROTTLE AND SHIFT CONTROLS

## DTS Foot Throttle Operation

DTS foot throttle operation is generally used on boats that can reach significant speeds. The use of a foot throttle allows the operator to keep both hands on the steering wheel at all speeds, which allows the operator greater control of the boat.

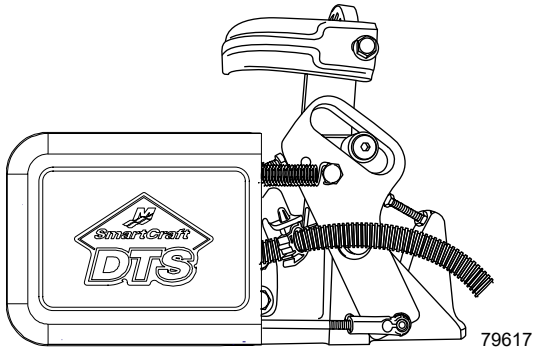

**Foot throttle**

## Switching Between Hand and Foot Control Operation

Engine speed is controlled from idle to WOT by either the foot throttle or the remote control handle.

The default settings when the engine is started are:

- Throttle control at the remote control handle.
- The hand throttle indicator light is on.

To transfer throttle control from the foot control to the remote control handle:

1. Place the throttle control handle in neutral or in the forward or reverse detent position.

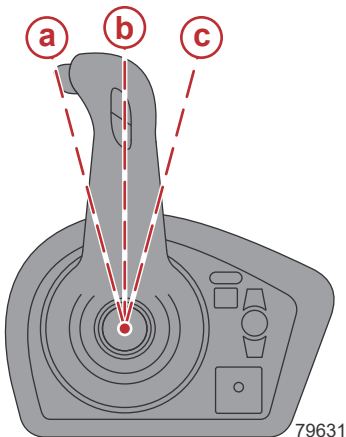

- a** - Forward detent position
- b** - Neutral detent position
- c** - Reverse detent position

# DIGITAL THROTTLE AND SHIFT CONTROLS

2. Push the dash-mounted **HAND THROTTLE** button.
  - The hand throttle indicator light will illuminate.
  - Throttle control will be available at the remote control handle.



- a** - Hand throttle button (dash-mounted)  
**b** - Hand throttle indicator light

**NOTE:** If the transfer fails, the hand throttle light will blink twice.

To return throttle control to the foot throttle from the remote control handle:

1. Place the throttle control handle in neutral or in the forward/reverse detent position.
2. Push the dash-mounted **HAND THROTTLE** button.
  - The hand throttle indicator light will be off.
  - Throttle control will be available at the foot throttle.

**NOTE:** If the transfer fails, the hand throttle light will blink twice.

## Active Trim

### Introduction to Active Trim

Active Trim is Mercury Marine's patented GPS-based automatic trim system. This intuitive, hands-free system continually adjusts engine or drive trim for changes in operating conditions to improve performance, fuel economy, and ease of operation. It responds to boat maneuvers with precision and delivers a better overall driving experience. No knowledge of trimming an engine or drive is needed to take advantage of Active Trim.

- As the boat accelerates, the engine or drive will trim out.
- As the boat decelerates, for example, while making a turn, the engine or drive will trim in.
- Active Trim can be overridden at any time by using the regular, manual trim buttons.
- Active Trim allows the boat operator to compensate for changes in boat load, driver preferences, and weather conditions while maintaining full automatic control.

### Modes of Operation

The Active Trim system has four modes of operation:



#### 1. Idle speeds

Maintains the existing trim position.

# DIGITAL THROTTLE AND SHIFT CONTROLS



## 2. Acceleration (hole shot)

Tucks the engine or drive under to minimize bow rise and improve time-to-plane.



## 3. Planing speeds

Progressively trims the engine or drive based on GPS speed to maintain the most efficient running attitude.

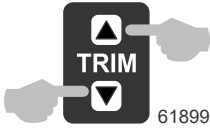

## 4. Override

When the boat operator uses manual trim, the Active Trim system is immediately overridden, returning full control to the operator.

### Setup and Configuration

Contact a Mercury Marine authorized dealer for setup and configuration instructions.

### Active Trim ERC Controls

**IMPORTANT: Authorized Mercury dealers have the ability to disable the Active Trim feature. In this case, the Active Trim buttons and lights on the ERC will not function.**

# DIGITAL THROTTLE AND SHIFT CONTROLS

Use the buttons and lights on the ERC to control the Active Trim feature.

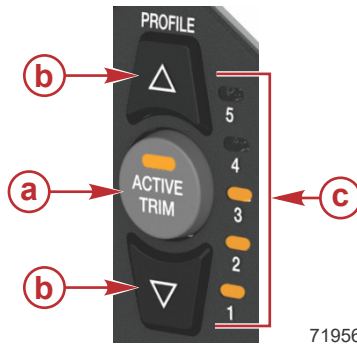

71956

**Active Trim controls on the ERC**

Ref	Control/LED	Function
	<b>ACTIVE TRIM</b> button	Turns the Active Trim feature on or off.
a	System status light	Provides Active Trim status information: <ul style="list-style-type: none"> <li>• A constant amber light indicates that the system is working normally.</li> <li>• A flashing amber light indicates that the Active Trim system is not controlling trim (user override). Press the <b>ACTIVE TRIM</b> button to resume Active Trim control.</li> <li>• A flashing red light indicates a problem with the system. Refer to <b>Active Trim Red Status Light</b>.</li> </ul>
b	<b>PROFILE</b> select buttons (▲ and ▼)	Up (▲) - Changes the adjustable trim profile to a more aggressive trim curve (more trim angle). Down (▼) - Changes the adjustable trim profile to a less aggressive trim curve (less trim angle).
c	Selected profile indicator LEDs (1, 2, 3, 4, 5)	Indicates the adjustable profile currently engaged. 1 is the least aggressive trim profile; 5 is the most aggressive. <b>NOTE:</b> If the LED indicators are flashing, Active Trim is in setup mode.

## Active Trim Operation

- Active Trim automatically controls trim to maintain the optimum engine or drive position based on engine RPM and boat speed.
- Active Trim progressively trims out the engine or drive to maintain an efficient running attitude.

# DIGITAL THROTTLE AND SHIFT CONTROLS

- Active Trim will maintain the last known trim position when operating at speeds in excess of 80 km/h (50 mph).
- Operation above 80 km/h (50 mph) may require trim adjustments using the panel-mounted or control handle trim position switch.
- Active Trim will gradually return the engine or drive to the down position during deceleration.
- Active Trim will only function when the engine or drive is in the normal trim range.

## GPS

Active Trim uses a GPS signal to determine boat speed. The Active Trim system will not automatically control trim until the GPS unit has acquired a signal.

### Resume Functionality

If the boat operator overrides the Active Trim system at planing speeds using the trim button, or exceeds 80 km/h (50 mph), the system will stop controlling the trim. Active Trim will resume automatically under the following conditions:

- Override occurred above 80 km/h (50 mph) and the boat then decelerates to below 80 km/h (50 mph).
- Override occurred above 80% of the rated engine RPM and the boat then decelerates to below 80% of the rated engine RPM.
- Override occurred in the cruising speed range and then the boat decelerates to idle. Active Trim will become active on the next acceleration.

### Shallow Water Operation

Active Trim cannot detect water depth and will not trim up automatically in shallow water. The boat operator will need to override Active Trim by trimming the engine or drive manually or pressing the **Active Trim** button.

### Trailer Position

Placing the engine or drive in trailer position (over 50% of the adapted trim range) will prevent Active Trim from engaging. Any time the engine or drive is trimmed above its normal range—to navigate shallow water, launch the boat from a trailer, or load the boat onto a trailer, for example—the engine or drive must be manually trimmed down before Active Trim will function. This safety feature is meant to prevent the engine or drive from automatically trimming down and hitting something.

### Selecting the Correct Profile

With so many available trim profiles, it can be difficult to determine which profile is the correct one. In making this determination, it is important to understand what trim is, how it affects boat operation, and how boat loading can influence the required trim angle. Armed with a clear understanding of these concepts, selecting the correct trim profile becomes simple.

# DIGITAL THROTTLE AND SHIFT CONTROLS

## What Trim Is

The trim angle of an outboard or sterndrive is the angle between the boat bottom and the propeller shaft formed by moving the engine or sterndrive closer to the boat transom. This movement is called trimming in or down. Moving the engine or sterndrive further away from the transom is called trimming out or up. When a boat is cruising on plane and the trim is adjusted so that the propeller shaft is parallel to the surface of the water, that is said to be running at zero trim.

The term "trim" is generally used when referring to adjusting the outboard or sterndrive within the first 20° range of travel. This is the range used while operating the boat on plane. The term "tilt" is generally used when referring to adjusting the outboard or sterndrive further up or out of the water.

## How Trim Affects Boat Operation

The trim angle of the outboard or sterndrive has a distinct effect on the planing angle of the boat, which in turn significantly alters the top speed and handling. The engine or drive should be trimmed in for best start-up acceleration and shortest time to plane. The engine or drive should then be trimmed out for peak performance. Active Trim automatically handles this transition.

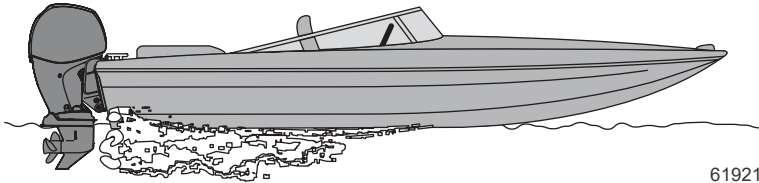

### Engine or drive properly trimmed

If the engine or drive is trimmed in too far, the bow drops and the boat runs too wet. In this condition, top speed drops, fuel economy decreases, the boat may oversteer in one direction or the other (bow steering), and steering torque will increase (to the right with a right-hand rotation propeller). Occasionally, extreme trim down can cause a boat to list to the left (with a right-hand propeller).

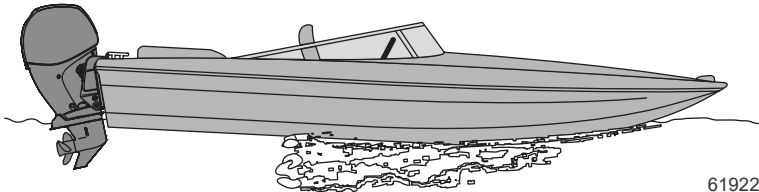

### Engine or drive trimmed in (bow too low)

# DIGITAL THROTTLE AND SHIFT CONTROLS

If the engine or drive is trimmed out too far, the propeller may lose its hold on the water, fast V-bottom boats may start to walk from side to side (chine walking), steering torque will increase in the opposite direction to that when trimmed in, and getting on plane may be difficult or labored. Porpoising of the boat may also occur.

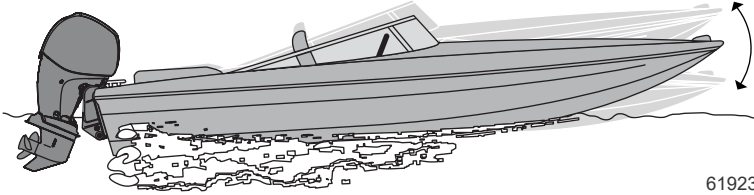

## Engine or drive trimmed out (bow too high); porpoising

### Boat Loading and Trim

Under normal loading and operating conditions while on plane, the boat bottom is roughly parallel to the surface of the water. Changing the loading of the boat will not change the trim angle as previously defined, but it will change the running attitude of the boat with respect to the surface of the water. Adding weight toward the stern of the boat will cause the bow to rise. Similarly, adding weight toward the bow of the boat will cause the bow to lower.

Changing the trim angle can compensate for a change in the running attitude of the boat. Increasing the trim angle will raise the bow of the boat, compensating for bow heavy loading. Decreasing the trim angle will lower the bow of the boat, compensating for stern heavy loading.

### Choosing an Active Trim Profile

If Active Trim is configured properly, the normal setting for running on plane will be profile 2, 3, or 4. This allows the operator the flexibility to change the trim angle to compensate for variations in boat loading or other operating conditions. Selecting a higher number profile will raise the bow and selecting a lower number profile will lower the bow.

Use the preceding descriptions of trim in and trim out to help determine whether or not the boat is trimmed properly (refer to **How Trim Affects Boat Operation**). In general, this means increasing the trim profile until the bow begins to porpoise (rise and fall), and then backing off one level.

### Active Trim Red Status Light



A flashing red light can indicate different things, depending on if it is a single or a double flash sequence.

# DIGITAL THROTTLE AND SHIFT CONTROLS

## Single Flashing Red

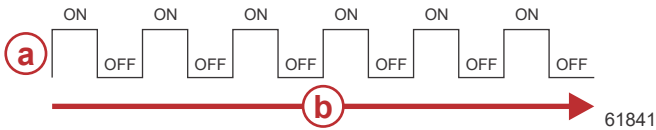

- a** - Light (on or off)
- b** - Interval

Fault Condition	Description	Notes
GPS signal intermittent	GPS signal has achieved fix, but is dropping out intermittently.	Indicates loss of GPS signal.
GPS signal unavailable	GPS has not achieved fix since key on.	Indicates obstructed GPS antenna or weak signal.

## Double Flashing Red

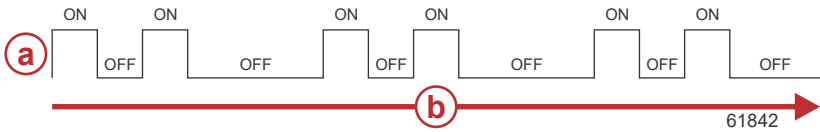

- a** - Light (on or off)
- b** - Interval

Fault Condition	Description	Notes
Trim up or trim down not achieved	The engine did not achieve its trim setpoint while attempting to trim up or down.	Indicates a problem with hydraulic pump operation, fuse, connection, trim sensor, or trim down circuit.

## Engine Synchronization (Multiple Engines)

Digital Throttle and Shift (DTS) engines have an automatic engine synchronization feature that engages automatically at key-up. Sync mode monitors the position of both ERC levers. If both levers are within 10% of one another, all engines synchronize to the starboard engine's RPM. The SmartCraft system will automatically disengage sync at the last 10% of the lever range to allow each engine the ability to reach the maximum available RPM. Sync mode cannot engage until its minimum RPM is met.

# DIGITAL THROTTLE AND SHIFT CONTROLS

## Helm Transfer

Some boats are designed to allow control from more than one location. These locations are commonly referred to as helms or stations. Helm transfer is a term used to describe the method of transferring control from one helm (or station) to another helm.

### **⚠ WARNING**

**Avoid serious injury or death from loss of boat control. The boat operator should never leave the active station while engine is in gear. Helm transfer should only be attempted while both stations are manned. One-person helm transfer should only be performed while engine is in neutral.**

The helm transfer function allows the boat operator to select which helm is in control of the boat. Before a transfer can be initiated, the ERC levers at the active helm and at the helm intended for the transfer must be in the neutral position.

**NOTE:** Attempting to transfer helm control when the ERC levers are not in neutral will cause a beep to sound. The helm transfer will not succeed until the levers at the helms are moved to neutral and the transfer is requested again.

Some fault codes may appear on the Mercury-approved multifunction display if other control or navigation functions are attempted after the helm transfer procedure is started. To remove the fault codes it may be necessary to cycle the key switch off and on, and then restart the helm transfer procedure. Ensure that other control and navigation inputs are performed after the helm transfer is complete to avoid setting fault codes.

### **NOTICE**

**The ERC levers must be in neutral to perform a helm transfer. While in neutral your vessel could drift and collide with objects nearby resulting in damage. Keep an adequate look out while performing the helm transfer.**

To avoid damage, use extra care when attempting a helm transfer while the boat is close to docks, piers, or other fixed items or when near other boats.

## Transfer Light and Single-Helm Boats

**IMPORTANT:** On boats with a single-helm, the TRANSFER light is constantly on, whenever the ignition key switch is on. This is normal.

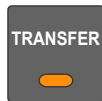

72258

## Requesting Helm Transfer

To request the transfer of boat control from one helm to another:

# DIGITAL THROTTLE AND SHIFT CONTROLS

1. All of the ignition keys must be in the **ON** position.
2. All of the boat's ERC levers must be in the neutral position.
3. At the helm to be made active, press the **TRANSFER** button once. The transfer light turns on and one beep will sound confirming the impending transfer.

**NOTE:** *If all ERC levers are not in neutral, the neutral lights will flash. Move all ERC levers to neutral and the neutral light will stop flashing.*

**NOTE:** *Any movement of the joystick (if equipped) or ERC levers after pressing the transfer button terminates the helm transfer request. A single beep sounds and the transfer button light turns off signaling the end of the transfer request.*



4. With the transfer light and neutral light on, press the **TRANSFER** button a second time to complete the helm transfer.
  - If the helm transfer is not completed in 10 seconds:
    - The request is automatically cancelled and a double beep sounds.
    - Control remains at the existing active helm. Press the transfer button again to restart helm transfer.
  - When the helm transfer is complete, another beep sounds.
    - The transfer light stays on at the active helm location.
    - The helm where the transfer request was initiated is now active and controls the boat.

## Helm Transfer and Autopilot

Transferring control from an active helm to an inactive helm (from one station to another station) affects the functionality of autopilot modes. Some of the effects are listed.

- Auto heading mode will disengage when the ERC levers are moved to the neutral position. Engage auto heading at the selected active helm.
- Requesting a helm transfer places the autopilot into standby mode. Any required inputs will need to be entered at the selected active helm.
- Skyhook will disengage when the transfer button is pressed the second time. Skyhook must be engaged at the selected active helm.
- If auto heading is activated, the helm transfer functionality is disabled. Turn this feature off and resume the transfer. At the selected active helm, engage auto heading.
- If route mode is activated, the helm transfer functionality is disabled. Turn this feature off and resume the transfer. At the selected active helm, engage route mode.

# DIGITAL THROTTLE AND SHIFT CONTROLS

- Route mode (waypoint sequencing) control of the route and display of route data on the chartplotter does not automatically transfer to the chartplotter at the active helm. Turn on the chartplotter at the selected active helm, input the waypoint route to be tracked, and engage route mode.

**IMPORTANT: If faults are encountered while attempting to complete a helm transfer, all controlling modules for the engine and the joystick piloting system must be turned off. To turn these controlling modules off, turn both engines off and place both engine ERC handles in reverse full throttle for three seconds.**

## Quick Steer

Quick Steer is available on boats equipped with single-outboard Electric Steering. Electric steering versions of the panel mount and single-handle console ERCs have a button to enable the Quick Steer feature. This feature is meant to provide rapid steering and more precise throttle control when operating in tight quarters, such as when docking.



- Quick Steer decreases the number of steering turns, lock-to-lock, at the helm to approximately quarter-turn each direction, while still providing full steering capacity.
- Quick Steer limits engine speed.

## Single-Lever Mode (Multiple Engines)

Dual-handle console ERCs feature the ability to command all engines with a single-lever. This feature simplifies engine management. Single-lever mode has no affect on the joystick function (if equipped).



### To engage single-lever mode:

1. Place both ERC levers in neutral.
2. Press **1 LEVER**. The single-lever light will turn on.
3. Place the port ERC lever into gear.
4. The RPM on all engines will increase and decrease in sync, while all drives remain in gear.

### To disengage single-lever mode:

1. Place both ERC levers in neutral.
2. Press **1 LEVER**. The single-lever light will turn off.

# DIGITAL THROTTLE AND SHIFT CONTROLS

## Start/Stop All Engines

Dual-handle console ERCs have a **START/STOP ALL ENGINES** button, which allows starting or stopping all engines with a single button push. The exact behavior of the engines depends on:

- How many engines are running when the button is pressed (none, all, or some)
- Whether a particular engine's key switch is on or off.
- What other actions the operator takes immediately after pressing the **START/STOP ALL ENGINES** button



## Engine Indicator LEDs

LEDs on the **START/STOP ALL ENGINES** button and the individual engine **START/STOP** buttons (on the aft end of the ERC) indicate the status of all engines.

## No Engines Running - Start Engines

When no engines are running (and no engine status LEDs are lit), press the **START/STOP ALL ENGINES** button to start all engines.

1. The LED on the **START/STOP ALL ENGINES** button turns on.
2. The engines will start according to the following sequence (as equipped):
  - a. Starboard outer engine - the LED on the starboard outer (**S**) button will light when the engine starts.
  - b. Port outer engine - the LED on the port outer (**P**) button will light when the engine starts.
  - c. Starboard inner engine - the LED on the starboard inner (**C** or **SC**) button will light when the engine starts.
  - d. Port inner engine - the LED on the port inner (**PC**) button will light when the engine starts.

Certain conditions will cause an engine to be skipped in the starting sequence. The starting sequence will ignore an engine and continue with any remaining engines, if:

- SmartStart times out (around 8 seconds) for an engine
- The ignition key switch is off for an engine (the starting sequence will proceed with no delay)

## All Engines Running - Stop Engines

When all engines are running (and all engine status LEDs are lit), press the **START/STOP ALL ENGINES** button to stop all engines. All engine status LEDs (individual and the **ALL ENGINES** LED) will turn off.

# DIGITAL THROTTLE AND SHIFT CONTROLS

## Some (Not All) Engines Running - Stop Engines

When some but not all engines are running (and the corresponding engine status LEDs are lit), press the **START/STOP ALL ENGINES** button to stop all running engines. All engine status LEDs (individual and the **ALL ENGINES** LED) will turn off.

## Interrupting the Start All Process

Pressing any **START/STOP** button or turning an ignition key switch during engine start up is not recommended.

## Throttle and Shift Operation with Three or Four Engines

### Triple-Engine Throttle and Shift Operation

Movement of the handles on the remote control allows the boat operator to control the engine throttle speed and gear shift positions of all three engines.

The throttle and shift function is dependent on what engines are running. Refer to the following table.

Port Engine	Center Engine	Starboard Engine	Control Handle Function
Running	Running	Running	Port engine throttle and shift = controlled by port control handle
			Starboard engine throttle and shift = controlled by starboard control handle
			Center engine throttle = shadows the engine with the lowest throttle setting until the port and starboard engine are within 10% of one another at which point all engines synchronize to the starboard engine's RPM.
			Center engine shift = neutral unless both engines are in the same gear
Running	Running	Off	Port and center engine throttle and shift = controlled by port control handle
Off	Running	Running	Starboard and center engine throttle and shift = controlled by starboard control handle
Running	Off	Running	Port engine throttle and shift = controlled by port control handle
			Starboard engine throttle and shift = controlled by starboard control handle

# DIGITAL THROTTLE AND SHIFT CONTROLS

Port Engine	Center Engine	Starboard Engine	Control Handle Function
Running	Off	Off	Port engine throttle and shift = controlled by port control handle
Off	Off	Running	Starboard engine throttle and shift = controlled by starboard control handle
Off (ignition key switch turned <b>ON</b> )	Running	Off (ignition key switch turned <b>ON</b> )	Center engine throttle and shift = neutral/idle unless both control handles are in the same gear

Turning off one of the outer engines while underway will cause the center engine to go into forced neutral/idle. Operation to the center engine can be restored by moving the control handle of the functioning outer engine back into neutral position and then engaging. The center engine speed and gear shift will then be controlled by the functioning outer engine.

Turning off the center engine while underway will have no effect on the operation of the outer engines.

If a failure should occur while underway which causes one of the outer engines into forced neutral/idle condition, the center engine will also be forced to neutral/idle. Operation to the center engine can be restored by moving the control handle of the functioning outer engine back into neutral and then engaging.

## Quad-Engine Throttle and Shift Operation

Movement of the handles on the remote control allows the boat operator to control the engine throttle speed and gear shift positions of all four engines.

The throttle and shift function is dependent on what engines are running. Refer to the following table.

Port Outer Engine	Port Inner Engine	Starboard Inner Engine	Starboard Outer Engine	Control Handle Function
Running	Running	Running	Running	Port inner and outer engines throttle and shift = controlled by port control handle
				Starboard inner and outer engines throttle and shift = controlled by starboard control handle

# DIGITAL THROTTLE AND SHIFT CONTROLS

<b>Port Outer Engine</b>	<b>Port Inner Engine</b>	<b>Starboard Inner Engine</b>	<b>Starboard Outer Engine</b>	<b>Control Handle Function</b>
Running	Running	Off	Off	Port inner and outer engine throttle and shift = controlled by port control handle
Off	Off	Running	Running	Starboard inner and outer engine throttle and shift = controlled by starboard control handle
Off (ignition key switch turned <b>ON</b> )	Running	Running	Running	Port inner engine throttle and shift = controlled by port control handle
Running	Running	Running	Off (ignition key switch turned <b>ON</b> )	Starboard inner engine throttle and shift = controlled by starboard control handle
Off (ignition key switch turned <b>OFF</b> )	Running	Running	Running	Port inner engine throttle and shift = controlled by starboard control handle
Running	Running	Running	Off (ignition key switch turned <b>OFF</b> )	Starboard inner engine throttle and shift = controlled by port control handle
Running	Off	Off	Running	Port outer engine throttle and shift = controlled by port control handle
				Starboard outer engine throttle and shift = controlled by starboard control handle

# DIGITAL THROTTLE AND SHIFT CONTROLS

Port Outer Engine	Port Inner Engine	Starboard Inner Engine	Starboard Outer Engine	Control Handle Function
Off (ignition key switch turned <b>ON</b> )	Running	Running	Off (ignition key switch turned <b>ON</b> )	Port inner engine throttle and shift = controlled by port control handle
				Starboard inner engine throttle and shift = controlled by starboard control handle

Turning off the starboard outer engine while underway will cause the starboard inner engine to go into forced neutral/idle. Operation to the inner engine can be restored by turning the starboard outer engine ignition key to the **ON** position and moving the starboard control handle back into neutral position and then engaging. The inner engine speed and gear shift will then be controlled by the starboard control handle.

Turning off the port outer engine while underway will cause the port inner engine to go into forced neutral/idle. Operation to the inner engine can be restored by turning the port outer engine ignition key to the **ON** position and moving the port control handle back into neutral position and then engaging. The inner engine speed and gear shift will then be controlled by the port control handle.

Turning off one of the inner engines while underway will have no effect on the operation of the outer engines.

If a failure should occur while underway which causes the starboard outer engines into forced neutral/idle condition, the inner starboard engine will also be forced to neutral/idle. Operation to the inner engine can be restored by moving the starboard control handle back into neutral and then engaging.

If a failure should occur while underway which causes the port outer engines into forced neutral/idle condition, the inner port engine will also be forced to neutral/idle. Operation to the inner engine can be restored by moving the port control handle back into neutral and then engaging.

## Throttle-Only Mode

Placing the ERC in throttle-only mode will avoid unintended gear engagement. The engines or drives will turn using the steering wheel or the joystick and the RPM of the engines can be increased while in throttle-only mode, but the gear position will remain in neutral.



72259

### To engage throttle-only mode:

1. Place both ERC levers into neutral.

# DIGITAL THROTTLE AND SHIFT CONTROLS

2. Press **THROTTLE ONLY**. The throttle-only light will turn on and the neutral lights will blink.
3. Place either ERC lever into forward or reverse detent position. The warning horn will beep each time the levers are moved into or out of gear while in throttle-only mode, but the drive will remain in neutral.

**NOTE:** *Throttle-only mode also affects the joystick, if equipped. The drives will move and the RPM can be increased, but the gear position will remain in neutral.*

4. The RPM of the engines can be increased.

## **To disengage throttle-only mode:**

1. Place both ERC levers into neutral. Throttle-only mode will not disengage unless the ERC levers are in neutral.

**NOTE:** *Pressing **THROTTLE ONLY** while the ERC levers are in gear will only turn off the throttle-only light. The engines will remain in throttle-only mode until the operator returns the levers to the neutral position.*

2. Press **THROTTLE ONLY**. The throttle-only light will turn off.
3. The neutral lights stop flashing and remain illuminated. Either the ERC levers or the joystick (if equipped) can now be used to control the boat's movement.

# FEATURES

## Adaptive Speed Control

This outboard package utilizes adaptive speed control which automatically adjusts the engine load (throttle) to maintain engine speed (RPM). For example, when the boat operator steers into a hard turn, which results in increased load on the engine and a loss of RPM, the propulsion control module (PCM) will open the throttle to maintain RPM through the turn, without the need for the operator to increase the remote control throttle handle. Another example is when cruising or utilizing the boat for tow sports, engine speed will remain constant, regardless of load changes due to waves, trim position, turning or load changes from tow sports. Adaptive speed control is active from idle RPM up to max rated RPM, however, can only maintain engine speed when the throttle is less than wide open.

## Warning System

### Warning Horn Signals

When the key switch is turned to the **ON** position, the warning horn will sound briefly to indicate it is functional. This is normal.

There are two types of warning horn signals to alert the operator of an active problem within the engine's operating system.

1. **Continuous six second beep:** Indicates a critical engine condition. Depending on the condition, the Engine Guardian system may engage and protect the engine by limiting its power. Return to port immediately and contact an authorized dealer.
2. **Intermittent short beeps for six seconds:** Indicates a noncritical engine condition. This condition does not require immediate attention. Continue boating. Depending on the nature of the problem, the engine's power may be limited by the Engine Guardian system to protect the engine (refer to **Engine Guardian System**). Contact a Mercury Marine authorized dealer at the first convenience.

In either of the preceding scenarios, the horn will sound only one time. The horn signal will sound again upon shut down and restart, if the fault that triggered the signal is still present.

A few of the noncritical conditions indicated by the intermittent short beeps for six seconds can be corrected by the operator. These operator correctable conditions include:

- Water in the boat-mounted fuel filter. Replace the filter. Refer to **Maintenance - Boat-Mounted Fuel Filter**.
- Cooling system (water pressure or engine temperature) problem. Stop the engine and check the water intake holes in the lower unit for obstruction.
- Low engine oil level. Refer to **Fuel and Oil - Checking and Adding Engine Oil**.

# FEATURES

## Engine Guardian System

The Engine Guardian system monitors the critical sensors on the engine for any early indications of problems. Engine Guardian is functional whenever the engine is operating, so there is never a concern about whether or not the engine is protected. The system will respond to a problem by sounding the warning horn for six seconds or reducing engine power in order to provide engine protection.

- If Engine Guardian has been activated, reduce the engine speed.
- The system must be reset before the engine will operate at higher speeds. Moving the throttle lever back to the idle position will reset the Engine Guardian system.
- If the Engine Guardian system determines that the reset has not corrected the problem, Engine Guardian will remain activated, continuing to limit the throttle. The problem must be corrected before Engine Guardian will allow the engine to reach a normal operating speed.

## Overspeed Rev Limit

The overspeed rev limit is set at an RPM greater than the operating range. In the event that the engine is operated at an RPM greater than or equal to the overspeed limit, the PCM does not allow the engine to maintain the power requested by the operator. Refer to **General Information - Specifications** to determine this engine's RPM limit.

Upon reaching the beginning of the overspeed rev limit, Engine Guardian will cut fuel to one bank of cylinders. If the operator does not reduce engine speed, Engine Guardian will cut the fuel to all cylinders until the engine speed has dropped below the rev limit. There is no audible warning while Engine Guardian overspeed limit is active.

## Exhaust Gas Over Temperature

When the Engine Guardian system detects the exhaust gas temperature is high (fault code 2124-20), the warning horn will beep and the engine RPM will be limited. SmartCraft gauges that have the ability display text will alert the operator with a short text, long text, and the action that the operator should follow. This Guardian warning and engine power reduction can possibly be corrected by inspecting the gearcase water inlets for blockage.

SmartCraft Displayed Text	
Short text	Critical - Overtemp
Long text	Engine exhaust manifold is overheating
Action	Stop engine and check for plugged exhaust water strainer. If condition persists return to port immediately. Service engine before next use.

1. Stop the engine.
2. Check the gearcase water inlets for blockage.

# FEATURES

3. If there is no blockage and the condition persists, return to port immediately.

## SmartCraft Product

A Mercury SmartCraft System instrument package can be purchased for this outboard. A few of the functions the instrument package will display are engine RPM, coolant temperature, oil pressure, water pressure, battery voltage, fuel consumption, and engine operating hours.

The SmartCraft instrument package will also aid in Engine Guardian diagnostics. The SmartCraft instrument package will display critical engine alarm data and potential problems.

## Power Trim and Tilt

Power trim allows the operator to easily adjust the position of the outboard by pressing the trim switch. Moving the outboard in closer to the boat transom is called trimming in or down. Moving the outboard further away from the boat transom is called trimming out or up.

**Trim** refers to the adjustment of the outboard within the first 20° range of travel. This is the range used while operating the boat on plane.

**Tilt** refers to adjusting the outboard further up out of the water. The outboard can be tilted up past the trim range for shallow water operation or loading the boat onto a trailer. With the engine turned off and the ignition switch turned on, the outboard can be tilted out of the water.

- Below 2000 RPM the engine can be trimmed or tilted to any range. Caution is advised when operating the engine past the trim range. Ensure that the water pickups are submerged.
- An engine that is operating above 2000 RPM within the trim range cannot be trimmed past the maximum trim range.
- If the engine is below 2000 RPM and is in the trailer range, advancing the throttle will allow the engine to achieve a maximum speed of 4250 RPM. Engine operation in this capacity (above the normal 2000 limit) should only be used for loading or unloading the boat onto or off the trailer. It should not be used during normal boat operation.

# FEATURES

**NOTE:** Exceeding 4250 RPM will engage Engine Guardian protection.

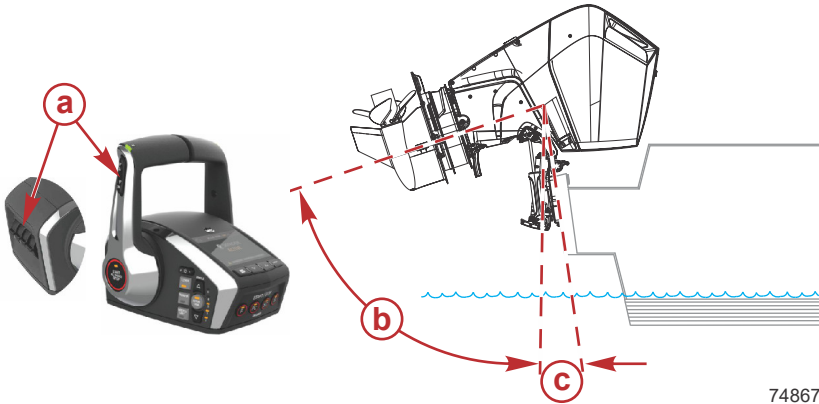

74867

- a** - Trim switch
- b** - Tilt range
- c** - Trim range

## Power Trim Operation

### **⚠ WARNING**

Operating the boat at high speeds with the outboard trimmed too far under can create excessive bow steer, resulting in the operator losing control of the boat. If experiencing poor handling due to excessive trim under, reduce the power gradually and trim the outboard out slightly before resuming high-speed operation.

### **⚠ WARNING**

Operating the boat at high speeds with the outboard trimmed too far out can reduce stability at high speeds. Rapidly reducing boat speed to correct this instability may cause a sudden change of steering torque and additional boat instability. If experiencing poor handling due to excessive trim out, reduce the power gradually and trim the outboard in slightly before resuming high-speed operation.

Typically, operating around the middle of the trim range will give satisfactory results. In certain situations, trimming the outboard all the way in or out will improve performance, but not without side effects.

The most significant side effect of changing the trim away from the middle of the range is a pull or torque that can be felt on the steering wheel. This steering torque results from the propeller shaft no longer being parallel to the water surface.

# FEATURES

Refer to **Outboard Operating Angle Considerations** for the benefits and detriments of changing the trim angle either in or out from the middle of the range.

## Outboard Operating Angle Considerations

Before adjusting the outboard operating angle from the middle of the range, consider the following benefits and detriments of changing the angle.

Adjusting the outboard close to the boat transom (down or in) can:

- Lower the bow.
- Result in quicker planing off, especially with a heavy load or a stern heavy boat.
- Generally improve the ride in choppy water.
- Increase steering torque or pull to the right (with the normal right-hand rotation propeller).
- In excess, lower the bow of some boats to a point where they begin to plow with their bow in the water while on plane. This can result in an unexpected turn in either direction (called bow steering or oversteering), if any turn is attempted or if a significant wave is encountered.

Adjusting the outboard away from the boat transom (out or up) can:

- Lift the bow out of the water
- Generally increase top speed
- Increase clearance over submerged objects or a shallow bottom
- Increase steering torque or pull to the left at a normal installation height (with the normal right-hand rotation propeller)
- Cause engine overheating if any cooling water intake holes are above the waterline
- In excess, cause boat porpoising (bouncing) or propeller ventilation

## Tilting to Full Up Position

### Tilt at Helm

**NOTE:** *The trim/tilt switch will remain active for 15 minutes after the ignition key switch has been turned off.*

1. If the ignition key switch has been turned off for over 15 minutes, turn it to the **ON** position.
2. Press the trim/tilt switch to the **UP** position. The outboard will tilt up until the switch is released or it reaches its maximum tilt position.

### Tilt at Engine

The cowl mounted auxiliary tilt switch can be used to tilt the outboard with the key switch in the **OFF** position. Refer to **Auxiliary Tilt Switch**.

### Tilt Support Lever

1. Rotate the tilt support lever down.
2. Lower the outboard until the tilt support bracket rests on the pedestal.

## FEATURES

- Disengage the tilt support bracket by raising the outboard up and rotating the tilt support lever up. Lower the outboard.

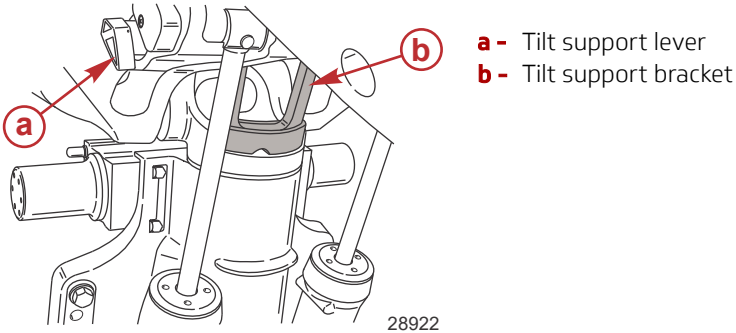

- a - Tilt support lever
- b - Tilt support bracket

### Manual Tilting

If the outboard cannot be tilted using the power trim/tilt switch, the outboard can be manually tilted. To manually tilt the outboard, turn the manual tilt release valve three turns counterclockwise. Tilt the outboard to the desired position and tighten the manual tilt release valve.

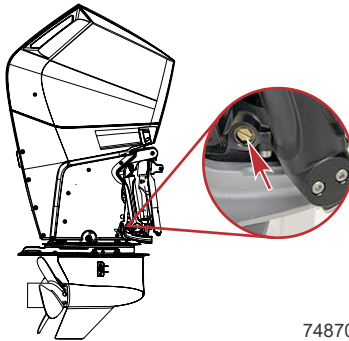

**NOTE:** The manual tilt release valve must be tightened before operating the outboard to prevent the outboard from tilting up during reverse operation.

# FEATURES

## Auxiliary Tilt Switch

The auxiliary tilt switch is located on the port side of the engine near the top of the lower cowl. This switch can be used to tilt the outboard up or down using the power trim system.

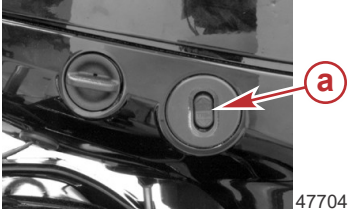

**a** - Auxiliary tilt switch

# FEATURES

Notes:

# OPERATION

## Engine Break-in Procedure

**IMPORTANT: Failure to follow the engine break-in procedures can result in poor performance throughout the life of the engine and can cause engine damage. Always follow break-in procedures.**

1. For the first two hours of operation, run the engine at varied throttle settings up to 4500 RPM or three-quarter throttle. Changes in throttle should be gradual and extended time at idle should be avoided.
2. For the next eight hours of operation, avoid continuous operation at full throttle for more than five minutes at a time.

## Important Daily Inspection Before Each Use

Any outboard mounted on the boat must have the mounting hardware inspected and checked to ensure that the hardware has not become loose. A decal on the transom bracket reminds the operator to check the fasteners securing the outboard to the transom before each use.

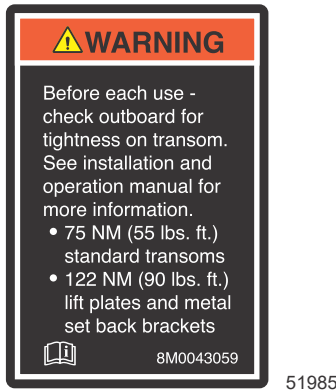

**Decal on the transom bracket**

## Prestarting Checklist

Before starting the outboard:

- Review the **Safe Boating Recommendations** in the **Important Safety Information** section of this manual.
- Perform all additional daily inspections and checks listed in **Maintenance - Inspection and Maintenance Schedule**.
- If the engine has less than 10 hours of operation, review the **Engine Break-in Procedure**.
- Ensure that the fuel supply is OK.

# OPERATION

## Starting the Engine

### NOTICE

**Without sufficient cooling water, the engine, the water pump, and other components will overheat and suffer damage. Provide a sufficient supply of water to the water inlets during operation.**

Before starting, read the **Prestarting Checklist**.

**NOTE:** Before starting an engine that has run out of fuel, refer to **Ran Out of Fuel Condition—Priming the Fuel System**.

1. Check the engine oil level. Refer to **Maintenance - Checking Engine Oil Level**.
2. Verify the cooling water intake is submerged.

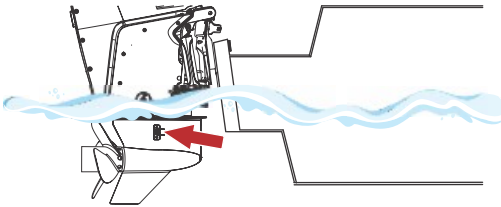

3. For manual venting type fuel tanks, open the vent screw on the fuel cap.

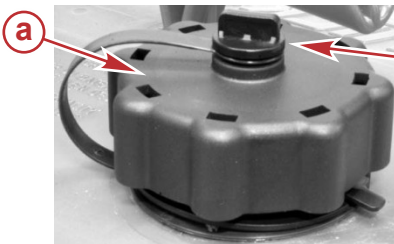

- a** - Fuel cap
- b** - Vent screw

# OPERATION

4. Set the lanyard stop switch to the **RUN** position. Refer to **Important Safety Information - Lanyard Stop Switch**.



19791

5. Shift the outboard to the neutral (N) position.



- a - Forward
- b - Neutral
- c - Reverse

71986

6. Turn the ignition key to the **START** position and release the key.
  - The electronic starting system will automatically crank the engine for starting.
  - If the engine fails to start, the engine will stop cranking.
  - Turn the key to the **START** position again until the engine starts.

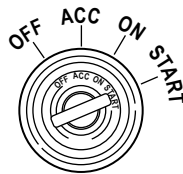

3485

# OPERATION

## Gear Shifting

**IMPORTANT: Observe the following:**

- **Never shift the outboard into or out of gear unless the engine speed is at idle. Shifting at higher than engine idle speed could cause damage to the gearcase.**
- **Do not shift the outboard into reverse when the forward motion of the boat is greater than a no wake speed. Shifting into reverse at higher boat speeds could cause the engine to stall, and in some situations, this could cause water to be drawn into the cylinders, resulting in severe engine damage.**
- The outboard has three gear shift positions: forward (F), neutral (N), and reverse (R).



- When shifting, always stop at the neutral position and allow the engine idle speed to stabilize before shifting into another gear.
- Panel mount and single-handle electronic remote controls require the operator to press the mechanical lock bar while moving the control handle out of the neutral position.



- a** - Mechanical lock bar—panel mount ERC
- b** - Mechanical lock bar—single-handle ERC

- Always shift the outboard into gear with a quick motion.
- After shifting the outboard into gear, advance the lever further to increase speed.

## Zero Effort Control Gear Shifting

1. Verify the throttle lever is at the idle position.
2. Move the shift lever to the forward or reverse position.

## OPERATION

3. Advance the throttle lever to apply power.



### Dual-engine control shown, others similar

- a - Shift levers in neutral position
- b - Throttle levers at the idle position

79618

## Stopping the Engine

**IMPORTANT: Turning the key to the START position while the engine is running will result in engine shut down, while leaving the DTS system active. This will allow the use of the power trim/tilt from the remote control handle.**

1. Reduce the engine speed to idle.
2. Shift the outboard into neutral.
3. Turn the ignition key to the **OFF** position.

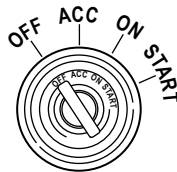

3482

## Proper Outboard Tilt Positioning During Periods of Non-Use

With the engine turned off, tilt the outboard up to a point where the trailing edge of the anti-ventilation plate is submerged and angled higher than the leading edge.

With the engine off, the outboard tilt angle will:

- Help to eliminate or reduce engine smoke on start-up. Tilting the outboard up allows oil in the cylinders to run down cylinders and return to the oil sump. With the outboard level or tilted in, oil from the cylinder walls can run down to the bottom of the cylinder and form a puddle behind the piston/rings. The oil can then weep into the combustion chamber. When the engine is started, the oil in the combustion chamber will burn, creating a smoke on start-up condition. As the engine runs, the smoke will gradually clear as the oil is consumed.

## OPERATION

- Provide additional impact clearance for the gearcase/propeller, when the boat is at rest in shallow water. Water depth can vary due to tides and wave action, reducing the impact clearance between the gearcase/propeller and the seabed.

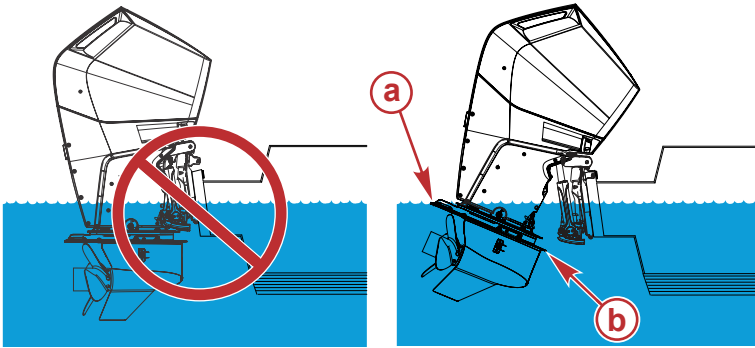

79140

**a** - Trailing edge of anti-ventilation plate

**b** - Leading edge of anti-ventilation plate

### Operating at High Elevations

Mercury Marine engines automatically compensate for high elevation changes, but there will still be some performance loss, due to the reduced oxygen in the air. A different pitch propeller may help reduce this normal performance loss. Consult an authorized dealer.

### Operating in Freezing Temperatures

If there is a chance of ice forming on the water, the outboard should be removed and drained completely of water. If ice should form at any level inside the outboard driveshaft housing between the water pump and the powerhead, it will block cooling water flow to the engine causing possible damage.

If the boat cannot be removed from the water during freezing temperatures, the following trim sequence should be performed:

1. Upon shutdown, allow the outboard to remain in the level trim position for five (5) minutes.
2. Using the outboard's trim switch, position the outboard at the full-tuck angle (nose of the gearcase should be as close to the boat's transom as possible) and allow the outboard to drain for an additional one (1) minute.

## OPERATION

3. For storage, tilt the outboard up so that the trailing edge of the anti-ventilation plate is protruding slightly above the water surface—refer to the illustration below. At this tilt angle, the engine's water pump and cooling water passages are best protected from freezing up with ice.

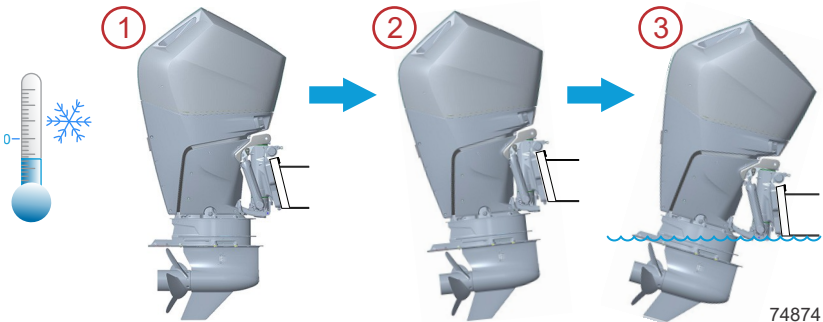

- 1 - Level trim, 5 minutes
- 2 - Full-tuck, 1 minute
- 3 - Trim out, for storage

### Operating in Saltwater or Polluted Water

Flush the outboard's internal water passages with fresh water after each use in salty or polluted water. This will prevent a buildup of deposits from clogging the water passages. Refer to **Maintenance - Flushing the Cooling System**.

If the boat is kept moored in the water, always (except in freezing temperatures) tilt the outboard up so the gearcase is completely out of water when not in use.

Wash the outboard exterior (Refer to **Maintenance - Cleaning Care Recommendations**) and flush out the exhaust outlet of the propeller and gearcase with fresh water after each use.

Each month, spray Mercury Precision or Quicksilver Corrosion Guard on external metal surfaces. Exercise care to not spray the corrosion control anodes, as this will reduce the anodes' effectiveness.

Description	Where Used	Part No.
Corrosion Guard	External metal surfaces	92-802878 55

### Operating in Shallow Water

When operating the boat in shallow water, the outboard can be tilted beyond the maximum trim range to prevent hitting bottom.

1. Reduce the engine speed below 2000 RPM.

# OPERATION

2. Tilt the outboard up. Make sure all the cooling water intake holes stay submerged at all times.
  - Below 2000 RPM the engine can be trimmed or tilted to any range. Caution is advised when operating the engine past the trim range. Ensure the water pickups are submerged.
  - If the engine is below 2000 RPM and is in the trailer range, advancing the throttle will allow the engine to achieve a maximum RPM of 4250. Engine operation in this capacity (above the normal 2000 limit) should only be used for loading or unloading the boat onto or off the trailer. It should not be used during normal boat operation.

**NOTE:** Exceeding 4250 RPM, the engine PCM will begin Engine Guardian protection.

## Setting Trim Angle While Running Engine at Idle Speed

The exhaust relief hole on the outboard can become submerged on some boats if the engine is trimmed full in while running at idle speed. This may result in exhaust restriction, rough idle, excessive smoke, and fouled spark plugs. If this condition exists, trim the outboard up until the exhaust relief hole is out of the water.

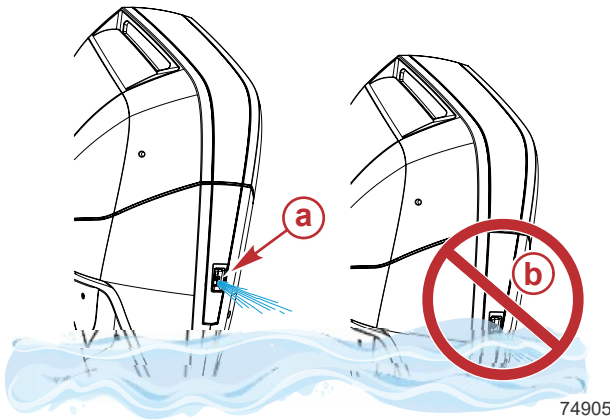

- a** - Relief hole above waterline (correct)
- b** - Relief hole submerged (wrong)

## Ran Out of Fuel Condition—Priming the Fuel System

In the event the engine is run out of fuel, the fuel system must be primed after fuel supply is restored. The fuel supply module (FSM) is non-vented and in order to prime the system air must be purged while operating the fuel pumps.

**IMPORTANT:** Repeated key ON events without purging air can damage the fuel pumps and is not effective in priming the fuel system.

## OPERATION

The objective is to purge the air entrained in the fuel system through the fuel injectors during engine cranking to allow fuel to enter the fuel module.

1. If possible, bring the engine to a vertical or close to vertical trim position.
2. Verify the vessel fuel supply line is connected to the outboard fuel system inlet fitting.
3. Turn the ignition key **ON**. The fuel pumps will run for approximately five seconds.
4. Turn the ignition key to the **START** position and release the key. The ECM controls the activation of the starter. The starter may continue cranking for up to eight seconds.

**NOTE:** *When priming the fuel system following a fuel runout, residual fuel may cause the engine to flare and stall which shortens the engine cranking event.*

5. Continue with the ignition key **ON** and **START** sequence until the engine continues to run.

**IMPORTANT: Allow the starter motor to cool for 20 to 30 seconds between full eight second crank events. Limit the number of events to a maximum of 15 full eight second cranking events.**

6. Once the engine starts, it may initially run rough at idle while the residual air is purged from the fuel system.
7. If the fuel system will not prime within 15 full eight second cranking events, contact an authorized Mercury Marine dealer to prime the fuel system with a fuel rail purge line.

# OPERATION

Notes:

# MAINTENANCE

## EPA Emissions Regulations

All new outboards manufactured by Mercury Marine are certified to the United States Environmental Protection Agency, as conforming to the requirements of the regulations for the control of air pollution from new outboard motors. This certification is contingent on certain adjustments set to factory standards. For this reason, the factory procedure for servicing the product must be strictly followed and, wherever practicable, returned to the original intent of the design. **Maintenance, replacement, or repair of the emission control devices and systems may be performed by any marine spark ignition (SI) engine repair establishment or individual.**

## Emission Certification Label

An emission certification label, showing emission levels and engine specifications directly related to emissions, is placed on the engine at the time of manufacture.

The diagram shows an emission certification label with the Mercury logo and the title "EMISSION CONTROL INFORMATION". The label contains the following text and fields:

- THIS ENGINE CONFORMS TO  CALIFORNIA AND U.S. EPA EMISSION REGULATIONS FOR SPARK IGNITION MARINE ENGINES
- REFER TO OWNERS MANUAL FOR REQUIRED MAINTENANCE SPECIFICATIONS AND ADJUSTMENTS
- IDLE SPEED (in gear):  L  H
- FAMILY:
- hp  L  g/kWh
- kw  CO FEL:  g/kWh
- SPARK PLUG:
- GAP:
- LOW PERM/HIGH PERM:

Callouts a-j point to the following fields:

- a - Idle speed
- b - Engine horsepower
- c - Piston displacement
- d - Engine power - kilowatts
- e - Date of manufacture
- f - US EPA engine family name
- g - Regulated emission limit for the engine family
- h - Regulated emission limit for the engine family
- i - Recommended spark plug and gap
- j - Percent of fuel line permeation

43210

- a** - Idle speed
- b** - Engine horsepower
- c** - Piston displacement
- d** - Engine power - kilowatts
- e** - Date of manufacture
- f** - US EPA engine family name
- g** - Regulated emission limit for the engine family
- h** - Regulated emission limit for the engine family
- i** - Recommended spark plug and gap
- j** - Percent of fuel line permeation

## Owner Responsibility

The owner/operator is required to have routine engine maintenance performed to maintain emission levels within prescribed certification standards.

The owner/operator is not to modify the engine in any manner that would alter the horsepower or allow emission levels to exceed their predetermined factory specifications.

# MAINTENANCE

## Cleaning Care Recommendations

### Outboard Care

To keep the outboard in the best operating condition, it is important that it receives the periodic inspections and maintenance listed in the **Inspection and Maintenance Schedule**. Proper maintenance helps ensure the safety of the operator and passengers and retains the engine's dependability.

Record all maintenance performed in the **Maintenance Log** at the back of this book. Save all maintenance work orders and receipts.

### Selecting Outboard Replacement Parts

For best results, use only original Mercury Precision or Quicksilver replacement parts and Genuine Lubricants.

### Do Not Use Caustic Cleaning Chemicals

**IMPORTANT: Do not use caustic cleaning chemicals on the outboard power package. Some cleaning products contain strong caustic agents such as hull cleaners with hydrochloric acid. These cleaners can degrade some of the components they come in contact with including critical steering fasteners.**

**Damage to steering fasteners may not be obvious during visual inspection and this damage may lead to catastrophic failure. Some caustic cleaning chemicals may cause or accelerate corrosion. Exercise caution when using cleaning chemicals around the engine and follow the recommendations on the packaging of the cleaning product.**

### Cleaning Gauges

**IMPORTANT: Never use high-pressure water to clean gauges.**

Routine cleaning of the gauges is recommended to prevent a buildup of salt and other environmental debris. Crystalized salt can scratch the gauge display lens when using a dry or damp cloth. Ensure that the cloth has a sufficient amount of fresh water to dissolve and remove salt or mineral deposits. Do not apply aggressive pressure on the display lens while cleaning.

When water marks cannot be removed with a damp cloth, mix a 50/50 solution of warm water and isopropyl alcohol to clean the display lens. **Do not** use acetone, mineral spirits, turpentine type solvents, or ammonia based cleaning products. The use of strong solvents or detergents may damage the coating, the plastics, or the rubber keys on the gauges.

If the gauge has a sun cover available, install the cover when the unit is not in use to prevent UV damage to the plastic bezels and rubber keys.

### Cleaning Remote Controls

**IMPORTANT: Never use high-pressure water to clean remote controls.**

# MAINTENANCE

Routine cleaning of the remote control external surfaces is recommended to prevent a buildup of salt and other environmental debris. Use a cloth towel that has a sufficient amount of fresh water to dissolve and remove salt or mineral deposits.

When water marks cannot be removed with a damp cloth, mix a 50/50 solution of warm water and isopropyl alcohol to clean the remote control. **Do not** use acetone, mineral spirits, turpentine type solvents, or ammonia based cleaning products. The use of strong solvents or detergents may damage the coating, the plastics, or the rubber components on the remote control.

## Cleaning Care for Top and Bottom Cowls

**IMPORTANT: Dry wiping (wiping the plastic surface when it is dry) will result in minor surface scratches. Always wet the surface before cleaning. Do not use detergents containing hydrochloric acid. Follow the cleaning and waxing procedure.**

### Cleaning and Waxing Procedure

1. Before washing, rinse the cowls with clean water to remove dirt and dust that may scratch the surface.
2. Wash the cowls with clean water and a mild nonabrasive soap. Use a soft clean cloth when washing.
3. Dry thoroughly with a soft clean cloth.
4. Wax the surface using a nonabrasive automotive polish (polish designed for clear coat finishes). Remove the applied wax by hand using a clean soft cloth.
5. To remove minor scratches, use Mercury Marine Cowl Finishing Compound (92-859026K 1).

**IMPORTANT: Do not rinse the cowls with water when the outboard is in a tilted position, as this could allow water to enter the air intakes (if equipped). Always lower the outboard to a vertical position prior to rinsing the cowls.**

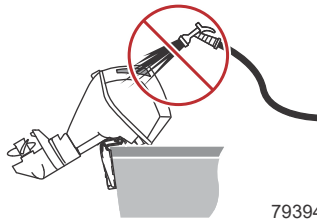

## Cleaning Care for the Powerhead (Saltwater Use)

If the outboard is operated in saltwater, remove the top cowl and flywheel cover. Inspect the powerhead and powerhead components for salt buildup. Wash off any salt buildup from the powerhead and powerhead components with fresh water. Keep water spray out of the air intake and alternator.

# MAINTENANCE

After washing, allow the powerhead and components to dry. Apply Quicksilver or Mercury Precision Lubricants Corrosion Guard spray on the external metal surfaces of the powerhead and powerhead components. Do not allow the Corrosion Guard spray to come in contact with the alternator drive belt or belt pulleys.

**IMPORTANT: Do not allow lubricant or Corrosion Guard spray to come in contact with the alternator drive belt or the belt pulleys. The alternator drive belt could slip and be damaged if it becomes coated with any lubricant or Corrosion Guard spray.**

Description	Where Used	Part No.
Corrosion Guard	External metal surfaces of the powerhead and powerhead components.	92-802878 55

## Use of Anti-fouling Bottom Paint

Some effective marine anti-fouling (bottom) paints use metals, such as copper, as the predominant biocide to prevent marine growth biofouling. The label of the paint may not reveal the actual contents or presence of a reactive metal used in the formula.

Anti-fouling paint for fiberglass or wood containing materials such as copper, graphite, or tin can cause corrosion if applied to aluminum propulsion components. The use of anti-fouling paints not approved for use on aluminum can create a galvanic corrosion cell, which can cause corrosion of aluminum propulsion components. Even the use of aluminum-safe anti-fouling paints should be done cautiously and with a clear understanding that the anti-fouling paint must not contain reactive metals.

## Application

The Mercury Marine factory paint process provides protection against corrosion caused by the marine environment. The original factory finish must be completely intact prior to the application of any aluminum-safe anti-fouling paints. Repairs to the finish may be necessary.

Contact a Mercury Marine authorized dealer for any necessary paint repairs and to ensure that the anti-fouling paint in question is safe for use on the propulsion components.

**NOTE:** *Sacrificial anodes should never be painted or have other types of coatings applied to them.*

## Warranty Coverage

The standard Mercury Marine corrosion warranty will still apply. Mercury Marine reserves the right to request that the customer supply a copy of the MSDS for the anti-fouling paint used, along with a receipt from the purchase and application of the product, in the event that a corrosion-related claim is made on a part that is coated with anti-fouling paint. Failure to produce these documents may result in denial of the corrosion warranty claim.

# MAINTENANCE

## Top Cowl Removal and Installation

**NOTE:** Remove and install the cowl while standing inside the boat.

### Removal

1. Tilt the outboard up so the top of the cowl is facing toward the boat.
2. Press the service access door release button. The service access door will open.



75220

- a** - Service access door release button
- b** - Service access door in open position

3. Press the red lock button and lift the handle.

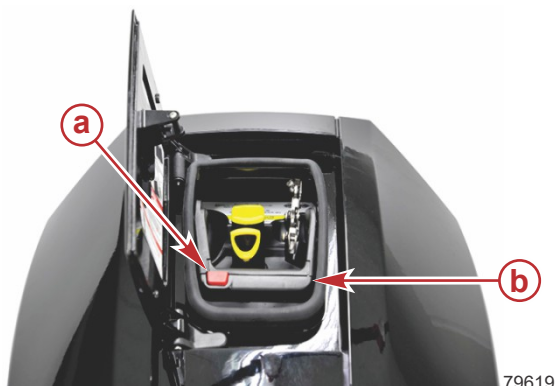

79619

- a** - Red lock button
- b** - Handle (shown in the cowl locked position)

# MAINTENANCE

4. Push the handle toward the aft until it clicks into the cowl lift position.

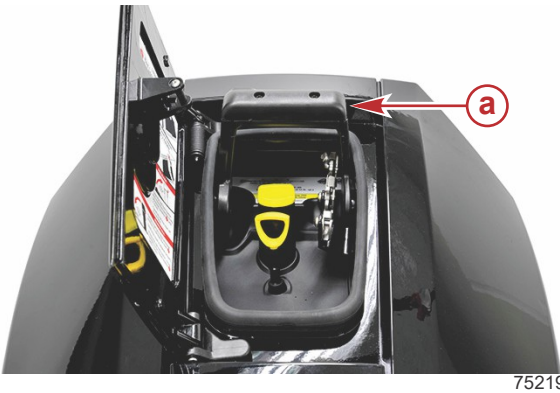

**a** - Handle locked in the cowl lift position

5. With a firm grip on the handle, carefully lift the cowl off the engine.

## Installation

1. With a firm grip on the handle, carefully lower the top cowl over the engine.
2. Verify the cowl is correctly aligned by checking the cowl alignment guides on the port and starboard side of the cowl. If there is misalignment, one side of the cowl will have a gap that is larger than the other side.

**NOTE:** *It may be necessary to slightly lift the larger gap side of the cowl to correctly position the alignment guides.*

3. Gently push down on the cowl.
4. Press the red lock button and push the handle down until it clicks into the locked position.
5. Close the service access door.

## Inspection and Maintenance Schedule

Refer to the tables below for proper inspection and maintenance intervals.

- I = Inspect
- R = Replace
- D = Dealer service

# MAINTENANCE

<b>Before Each Use</b>	<b>I/R/D</b>
Check that the lanyard stop switch stops the engine.	I
Check the propeller for damage.	I
Inspect the hydraulic steering fittings and hoses for leaks or damage, if equipped.	I
Check the steering system for binding or loose components.	I
Check the engine oil level. Refer to <b>Checking Engine Oil Level</b> .	I
Inspect the fuel system for leaks. Refer to <b>Fuel System</b> .	I
Inspect the power steering fluid level, if equipped. Refer to <b>Checking Power Steering Fluid</b> .	I
Inspect the tightness on transom. Refer to <b>Transom Tightness Inspection</b> .	I

<b>After Each Use</b>	<b>I/R/D</b>
Wash off all salt deposits and flush out the exhaust outlet of the propeller and gearcase with fresh water if operating in saltwater.	I
If operating in saltwater, inspect the powerhead and powerhead components for salt buildup. Refer to <b>Cleaning Care for the Powerhead (Saltwater Use)</b> .	I
Flush the outboard cooling system if operating in salt, polluted, or muddy water. Refer to <b>Flushing the Cooling System</b> .	I

<b>Every 50 Hours of Use For Extreme Duty Applications*</b>	<b>I/R/D</b>
Change the engine oil and filter. Refer to <b>Changing Engine Oil and Filter</b> .	R
Change the gearcase lubricant—Sport Master gearcases only. Refer to <b>Gearcase Lubricant</b> .	R

\*For extreme duty applications such as high-speed catamarans or surface piercing applications.

<b>100 Hour Maintenance (Every 100 Hours of Use or Once Yearly, Whichever Occurs First)</b>	<b>I/R/D</b>
Check cowl seals to ensure seals are intact and not damaged.	I
Check that the intake silencer is in place.	I
Check that the idle relief muffler is in place.	I
Check for loose hose clamps and rubber boots on the air intake assembly, if equipped.	I
Add Quickleen to the fuel tank. Refer to <b>Fuel and Oil - Fuel Additives</b> .	I
Inspect the engine starting battery. Refer to <b>Battery Inspection</b> .	I

# MAINTENANCE

<b>100 Hour Maintenance (Every 100 Hours of Use or Once Yearly, Whichever Occurs First)</b>	<b>I/R/D</b>
Inspect the battery cables and clean power harness. Refer to <b>Battery Cables and Clean Power Harness</b> .	I
Inspect the corrosion control anodes. Refer to <b>Corrosion Control Anodes</b> .	I
Change the engine oil and filter. Refer to <b>Changing Engine Oil and Filter</b> .	R
Check the boat-mounted water-separating fuel filter for the presence of water or contaminants. Drain the water or replace the filter if required. Refer to <b>Boat-Mounted Fuel Filter</b> .	I
Change the gearcase lubricant. Refer to <b>Gearcase Lubricant</b> .	R
Remove the propeller and lubricate the propeller shaft. Refer to <b>Propeller Replacement</b> .	I
Inspect the tightness on transom. Refer to <b>Transom Tightness Inspection</b> .	I
Inspect the main thermostat visually for corrosion or a broken spring. Ensure that the thermostat closes completely at room temperature.	D
Remove and inspect spark plugs for corrosion and replace as necessary. Apply Anti-Seize Compound only on threads of spark plug prior to installation. (This is especially important in saltwater applications.)	D
Inspect the inline fuel filter after the first 100 hours of operation.	D
Check tightness of bolts, nuts, and other fasteners.	D

<b>300 Hour Maintenance (Every 300 Hours of Use or Three Years, Whichever Occurs First)</b>	<b>I/R/D</b>
Replace the boat-mounted water-separating fuel filter. Refer to <b>Boat-Mounted Fuel Filter</b> .	R
Check the power trim fluid level. Refer to <b>Checking Power Trim Fluid</b> .	I
Replace the spark plugs.	D
Replace the accessory drive belt.	D
Replace the water pump impeller. (Replace more frequently if overheating occurs or reduced water pressure is noted.)	D
Inspect the crankcase cooler thermostat visually for corrosion or a broken spring. Ensure that the thermostat closes completely at room temperature.	D
Lubricate the splines on the upper driveshaft.	D
Apply Corrosion Guard to the starter Bendix gear and shaft.	D
Check wiring and connectors.	D











# MAINTENANCE

Refer to the **Storage** section for maintenance requirements for storage preparation.

## Maintenance Schedule Decals

### Maintenance Schedule Decal Icons

A maintenance schedule decal is located on the engine to remind the owner or operator when the power package important maintenance items require attention. The following table shows the icons and a general description of the scheduled maintenance items.

Icon	Definition	Icon	Definition
 58249	Replace	 58250	Inspect
 58251	Engine oil and filter	 58252	Gearcase lubricant
 58253	Spark plugs	 58254	Thermostat
 58255	Low-pressure fuel filter	 58256	Anodes
 58257	Accessory drive belt	 58258	Water pump impeller

# MAINTENANCE

## V10 Verado Models Maintenance Schedule Decal

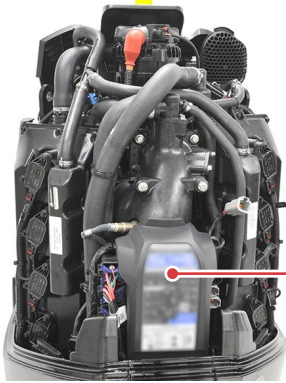

MAINTENANCE SCHEDULE																							
VERADO																							
EVERY 100 HOURS OF USE OR ONCE YEARLY	EVERY 300 HOURS OF USE OR THREE YEARS																						
<b>REPLACE</b>	<b>REPLACE</b>																						
Engine Oil and Filter	Spark Plugs*																						
Gearcase Lubricant	Low Pressure Fuel Filter																						
<b>INSPECT</b>	Accessory Drive Belt																						
Anodes	Water Pump Impeller																						
Thermostat																							
Spark Plugs*	For additional maintenance and storage preparation see Owner's Manual																						
Low Pressure Fuel Filter																							
Specifications																							
Full Throttle RPM: 5800-6400 Neutral Idle RPM: 650																							
<p><b>*In Saltwater:</b> Apply Anti-Seize 20 Nm (15 lb-ft) <b>8M0135348</b> 0.9 mm (0.035 in.)</p>	Engine Oil <table border="1"> <tr><td>100</td><td>40</td></tr> <tr><td>90</td><td>30</td></tr> <tr><td>80</td><td>20</td></tr> <tr><td>70</td><td>15</td></tr> <tr><td>60</td><td>10</td></tr> <tr><td>50</td><td>5</td></tr> <tr><td>40</td><td>0</td></tr> <tr><td>30</td><td>0</td></tr> <tr><td>20</td><td>0</td></tr> <tr><td>10</td><td>0</td></tr> <tr><td>0</td><td>0</td></tr> </table> <p>9.5 L (10.0 U.S. qt.)</p>	100	40	90	30	80	20	70	15	60	10	50	5	40	0	30	0	20	0	10	0	0	0
100	40																						
90	30																						
80	20																						
70	15																						
60	10																						
50	5																						
40	0																						
30	0																						
20	0																						
10	0																						
0	0																						

74956

# MAINTENANCE

## 400R Maintenance Schedule Decal

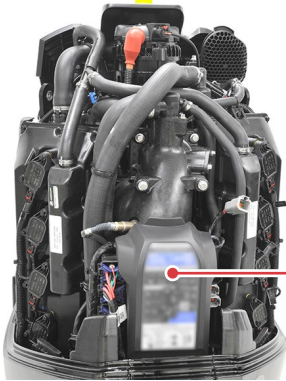

**MAINTENANCE SCHEDULE**

**EVERY 100 HOURS OF USE  
OR ONCE YEARLY**

<p><b>REPLACE</b></p>	<ul style="list-style-type: none"> <li>■ Engine Oil And Filter</li> <li>■ Gearcase Lubricant</li> </ul>
<p><b>INSPECT</b></p>	<ul style="list-style-type: none"> <li>■ Anodes</li> <li>■ Thermostat</li> <li>■ Spark Plugs*</li> <li>■ Low Pressure Fuel Filter</li> </ul>

**EVERY 300 HOURS OF USE  
OR THREE YEARS**

<p><b>REPLACE</b></p>	<ul style="list-style-type: none"> <li>■ Spark Plugs*</li> <li>■ Low Pressure Fuel Filter</li> <li>■ Accessory Drive Belt</li> <li>■ Water Pump Impeller</li> </ul>
-----------------------	---

For additional maintenance and storage preparation see Owner's Manual

<p><b>Specifications</b></p> <p><b>Full Throttle</b> RPM 400R: 6000-6600 Neutral Idle RPM: 650</p> <p><b>Spark Plug:</b> 8M0135348 <b>Gap:</b> 0.9 mm (0.035 in.) <b>Torque:</b> 20 Nm (15 lb-ft) Apply Anti-Seize Compound To Thread</p>	<p> <b>Engine Oil</b></p> <div style="display: flex; align-items: center;"> <div style="text-align: center;"> <table border="1" style="font-size: x-small;"> <tr><td>+120</td><td>+49</td></tr> <tr><td>+100</td><td>+38</td></tr> <tr><td>+80</td><td>+27</td></tr> <tr><td>+60</td><td>+16</td></tr> <tr><td>+40</td><td>+4</td></tr> <tr><td>+20</td><td>-7</td></tr> <tr><td>0</td><td>-18</td></tr> <tr><td>F°</td><td>C°</td></tr> </table> </div> <div style="margin: 0 10px;"> <p>25W-30</p> </div> </div> <p style="text-align: center;">9.5 L (10.0 U.S. qt.)</p>	+120	+49	+100	+38	+80	+27	+60	+16	+40	+4	+20	-7	0	-18	F°	C°
+120	+49																
+100	+38																
+80	+27																
+60	+16																
+40	+4																
+20	-7																
0	-18																
F°	C°																

74957

# MAINTENANCE

## V10 425hp Verado Maintenance Schedule Decal

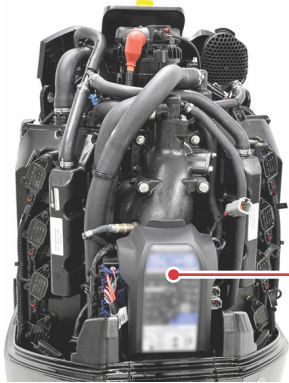

MAINTENANCE SCHEDULE	
VERADO	
<b>EVERY 100 HOURS OF USE OR ONCE YEARLY</b>	<b>EVERY 300 HOURS OF USE OR THREE YEARS</b>
<b>↕ REPLACE</b>	<b>↕ REPLACE</b>
Engine Oil and Filter	Spark Plugs*
Gearcase Lubricant	Low Pressure Fuel Filter
<b>✓ INSPECT</b>	Accessory Drive Belt
Anodes	Water Pump Impeller
Thermostat	For additional maintenance and storage preparation see Owner's Manual
Spark Plugs*	
Low Pressure Fuel Filter	
<b>Specifications</b>	
Full Throttle RPM: 6000-6600 Neutral Idle RPM: 650	
*In Saltwater: Apply Anti-Seize 20 Nm (15 lb-ft) 8M0135348 0.9 mm (0.035 in.)	Engine Oil  9.5 L (10.0 U.S. qt.)

80082

## Battery and Electrical

### Battery Inspection

**IMPORTANT: Read the safety and maintenance instructions that accompany the engine starting battery.**

Inspect the battery at periodic intervals to ensure proper engine starting capability.

1. Verify the engine is off before inspecting the battery.
2. Ensure that the battery is secure against movement.
3. Verify that the battery cable terminals are clean, tight, and correctly installed on the battery (positive to positive and negative to negative).
4. Verify the battery is equipped with a nonconductive shield to prevent accidental shorting of battery terminals.

### Battery Cables and Clean Power Harness

The battery cable connections should be checked often for corrosion or loose retaining hardware. Maintaining these electrical connections help ensure that engine operation and accessory functionality remain trouble-free.

# MAINTENANCE

The clean power harness connects to the engine rigging center and the engine starting battery.

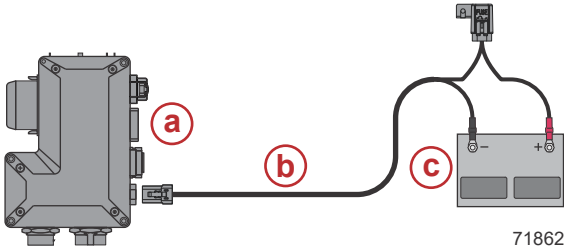

- a** - Engine rigging center
- b** - Clean power harness
- c** - Engine starting battery

The engine starting battery cables and the clean power harness wires must be secured to the engine starting battery with nuts. Wing nuts are not acceptable.

The clean power harness must be secured to one of the battery cables with a cable tie or other type of secure fastener.

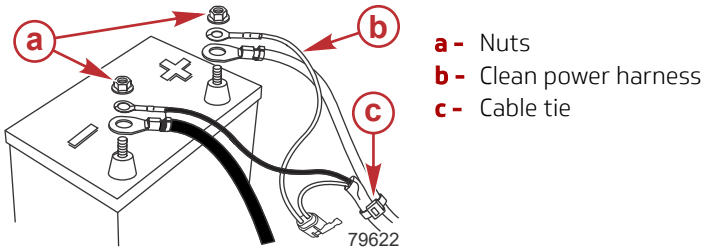

- a** - Nuts
- b** - Clean power harness
- c** - Cable tie

## Clean Power Fuse

**IMPORTANT: An ATC fuse has the fuse element enclosed or sealed inside the plastic housing. This type of fuse must be used for marine applications. Marine applications are exposed to environments that may have the potential to accumulate explosive vapors. ATO fuses have exposed elements and should never be used in marine applications.**

# MAINTENANCE

If the clean power harness fuse is open, try to locate and correct the cause of the overload. If the cause is not found, the fuse may open again. Remove the clean power fuse and look at the silver band inside the fuse. If the band is broken (open), replace the fuse with the same rating (30-amp) and type fuse.

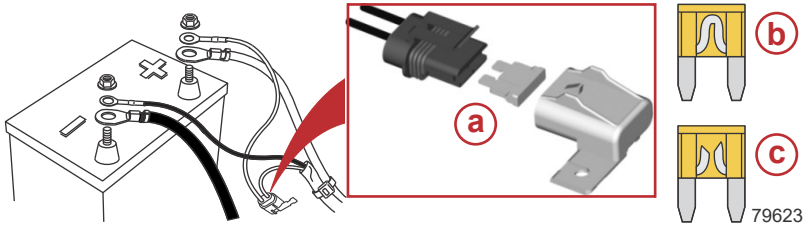

- a - Clean power harness fuse
- b - Good fuse
- c - Open fuse

## Battery Connections

**IMPORTANT: The engine electrical system is negative (-) ground.**

When connecting the engine battery, hex nuts must be used to secure the battery leads to the battery posts. Tighten the hex nuts to the specified torque.

Description	Nm	lb-in.	lb-ft
Battery hex nuts	13.5	120	-

## Order of Connection

Connect the battery cables in the following order:

1. All jumpers between parallel, multiple battery packs
2. From the batteries to the positive (+) engine lead
3. From the batteries to the positive (+) clean power
4. From the batteries to the negative (-) engine lead
5. From the batteries to the negative (-) clean power
6. From the batteries or main ground (-) bus to the negative (-) starboard helm main power relay

## Flushing the Cooling System

Flush the internal water passages of the outboard with fresh water after each use in salt, polluted, or muddy water. This will help prevent a buildup of deposits from clogging the internal water passages.

## Single-Engine Flush

**NOTE:** The outboard can be tilted or in the vertical operating position during flushing.

# MAINTENANCE

1. With the engine turned off, place the outboard in either the operating position (vertical) or in a tilted position.
2. Remove the flush connector from the bottom cowl on the port side of the engine.
3. Remove the cover from the flush connector and thread a water hose into the flush connector.

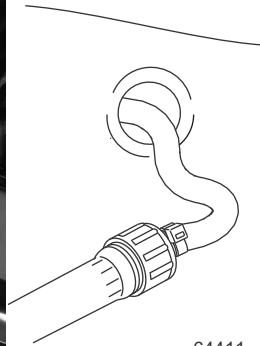

64411

4. Turn on the water tap (1/2 maximum) and let the water flush through the cooling system for about 15 minutes.
5. When flushing is complete, turn off the water and disconnect the water hose.
6. Install the cover on the flush connector. Place the flush connector back into the bottom cowl.

## Multiple-Engine Flush (With an Automatic Outboard Flushing System)

1. With the engines turned off, place the outboards in a convenient position.
2. Thread a water hose into the flush quick connector (5/8 in. garden hose recommended).

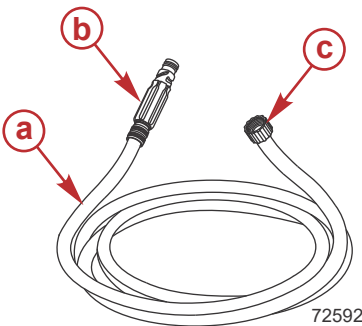

- a** - Water hose
- b** - Flush quick connector
- c** - To water tap

72592

# MAINTENANCE

3. Locate the engine flush port on the boat transom and insert the quick-connect fitting.

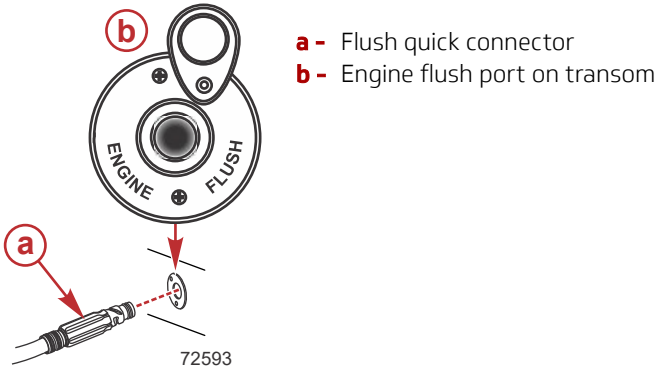

4. Turn on the water tap.
5. Press the start button on the boat-mounted automatic outboard flushing system, or the remote-mounted button if equipped. See the user manual that comes with the unit for more details.

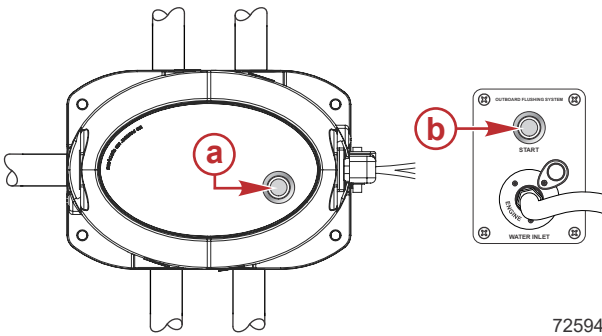

6. Once the system has completed the flushing procedure, turn off the water tap and remove the water hose.

## Corrosion Control Anodes

The outboard has corrosion control anodes at different locations. Anodes help protect the outboard against galvanic corrosion by sacrificing its metal to be slowly eroded instead of the outboard metals.

# MAINTENANCE

Each anode requires periodic inspection, especially in saltwater, which will accelerate the corrosion. To maintain corrosion protection, always replace the anode before it is completely corroded. Never paint or apply a protective coating on the anode, as this will reduce the effectiveness of the anode.

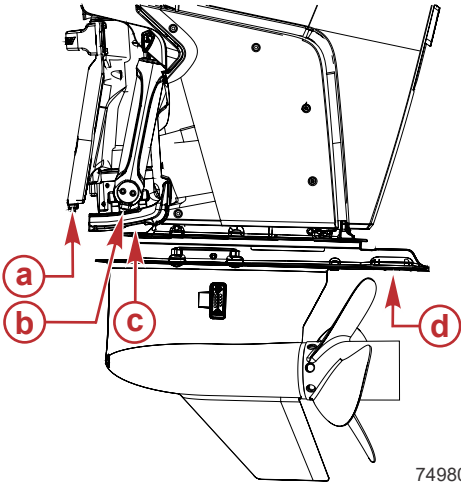

- a** - Bottom of transom bracket (1)
- b** - Bottom of each power trim ram (2)
- c** - Bottom of power trim pedestal (1)
- d** - Underside of anti-ventilation plate (1)

## Engine Oil and Filter

### Checking Engine Oil Level

**IMPORTANT: For an accurate oil level reading, the engine must be vertical for several minutes before removing the dipstick.**

After the engine oil has been changed, the engine should be run for a few minutes and then turned off, allowing one hour or longer before checking the oil level.

1. Remove the dipstick, wipe it clean, and install it fully into the dipstick tube.
2. Remove the dipstick and observe the oil level. The oil level should be within the safe operating range.
3. If the oil level is below the ADD mark, or is not visible on the dipstick, remove the oil fill cap and add 3.3 liter (3.5 US qt) of the specified engine oil.
4. Allow a few minutes for the oil to drain into the sump and insert the oil dipstick.

# MAINTENANCE

- Remove the dipstick and observe the oil level. Add oil as necessary to reach the target oil level (1/2 to 2/3 above the bottom of the dipstick crosshatch or ADD mark).

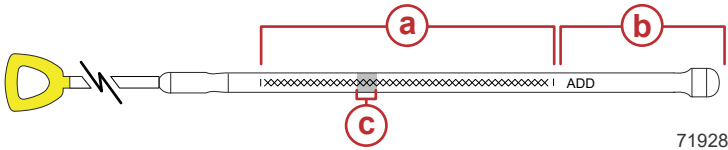

- a** - Safe operating range
  - b** - Add 3.3 liter (3.5 US qt) of oil
  - c** - Target oil level (1/2 to 2/3 above bottom of crosshatch)
- Install the dipstick and oil fill cap hand-tight.
  - Close the service access door.

## Changing Engine Oil and Filter

### Engine Oil Capacity

The engine oil capacity is approximately 9.5 liter (10.0 US qt).

### Oil Change On Land

- Tilt the outboard out/up past vertical for approximately one minute to allow any trapped oil to drain back to the oil sump.
- Tilt the outboard down to the vertical position.
- Use a 16 mm (5/8 in.) wrench to loosen the oil drain valve just enough so that it can be turned by hand. Do not open the valve so far as to allow oil to drain.
- Attach a 12 mm (7/16 in.) inside diameter drain hose to the oil drain valve. Position the opposite end of the hose into an appropriate container. The container should be large enough to hold more than 9.5 liter (10 US qt).

**IMPORTANT: Do not loosen the oil drain valve more than 2-1/2 turns. The oil seal could get damaged beyond 2-1/2 turns.**

# MAINTENANCE

- Loosen the oil drain valve 2-1/2 turns to allow oil to drain. Do not exceed 2-1/2 turns.

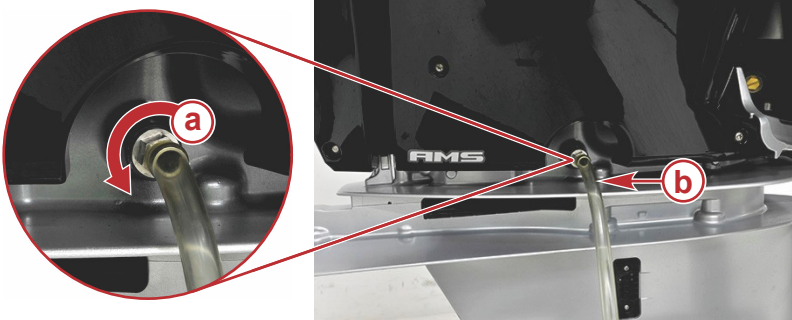

- a** - Oil drain valve, loosen 2-1/2 turns maximum
- b** - Drain hose

- After the oil has drained, hand-tighten the oil drain valve (clockwise) and remove the oil drain hose.

**IMPORTANT: Overtightening the oil drain valve can damage the oil sump.**

- Tighten the oil drain valve to the specified torque. Clean up any oil in the valve area.

Description	Nm	lb-in.	lb-ft
Oil drain valve	15	132.7	-

- Add the appropriate amount of engine oil. Refer to **Oil Filling**.

## Oil Change On Water

- Tilt the outboard out/up past vertical for approximately one minute to allow any trapped oil to drain back to the oil sump.
- Tilt the outboard to a vertical position.

# MAINTENANCE

3. Press the service access door release button. The service access door will open.



- a** - Service access door release button
- b** - Service access door in open position

4. Remove the dipstick.

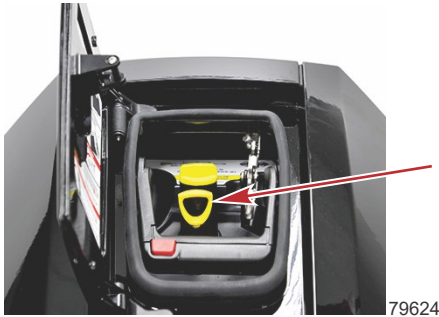

5. Install the oil drain hose onto the crankcase oil pump. Verify the hose is securely attached.

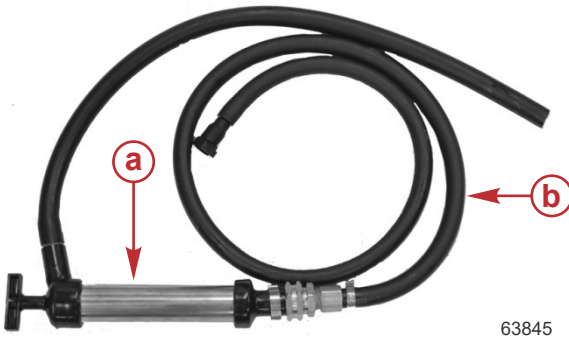

- a** - Crankcase oil pump (Mercury Marine P/N 802889A1)
- b** - Oil drain hose (Mercury Marine P/N 8M0129230)

# MAINTENANCE

6. Install the crankcase oil pump assembly onto the dipstick tube. Verify the pump is securely attached to the tube by pulling it up lightly

**NOTE:** A lock button secures the hose in place on the tube.

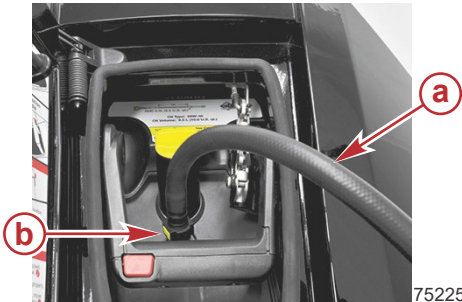

- a -** Oil drain hose (from crankcase oil pump assembly)
- b -** Lock button

7. Place the drain tube of the crankcase oil pump assembly into an appropriate container. The container should be large enough to hold more than 9.5 liter (10 US qt).
8. Extract the engine oil with the pump.
9. Allow the drain tube to completely drain before removing the oil pump from the dipstick tube.
10. Press the oil drain hose lock button to release it from the dipstick tube.
11. Install the dipstick. Verify it is completely inserted.
12. Add the appropriate amount of engine oil. Refer to **Oil Filling**.

## Changing Oil Filter

1. Remove the plug from the oil trough.

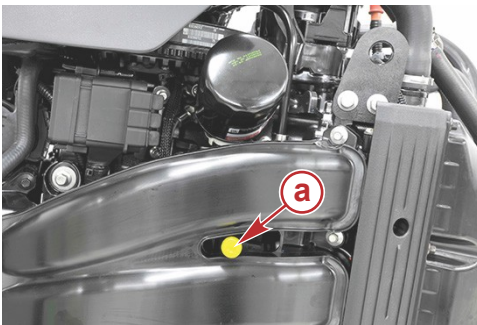

- a -** Oil trough plug

2. Attach a 12 mm (7/16 in.) I.D. drain hose to the fitting. Place the opposite end of the hose into an appropriate container.
3. Remove the old filter by turning the filter counterclockwise.

# MAINTENANCE

Oil Filter Wrench

91-889277002

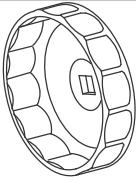

5221

Aids in the removal of the oil filter.

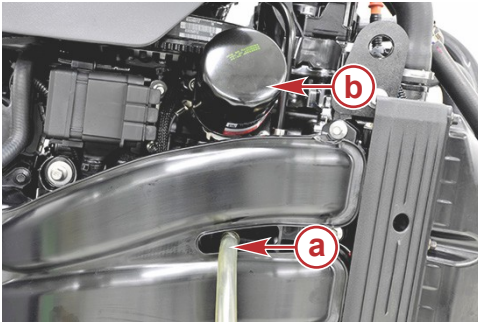

75227

- a** - Oil filter
- b** - Drain hose

4. Allow the oil in the trough to drain into an appropriate container.
5. Clean the remaining oil from the oil trough and filter mounting base area.
6. Remove the hose and install the plug.

**IMPORTANT: Do not use grease on the filter gasket.**

7. Apply a film of clean oil to the filter gasket. Install the new filter until the gasket contacts the base and then tighten  $3/4$  to 1 turn.

## Oil Filling

Remove the oil fill cap and add approximately 9.5 liter (10.0 US qt) of the recommended oil. This will bring the oil level within the operating range.



75228

- a** - Oil fill cap

# MAINTENANCE

**NOTE:** Do not check the oil level immediately after changing the oil. The engine must be run for a while and then turned off for one hour or longer before checking the oil level. Refer to **Checking Engine Oil Level**.

## Fuel System

### **⚠ WARNING**

**Fuel is flammable and explosive. Ensure that the key switch is OFF and the lanyard is positioned so that the engine cannot start. Do not smoke or allow sources of spark or open flame in the area while servicing. Keep the work area well ventilated and avoid prolonged exposure to vapors. Always check for leaks before attempting to start the engine, and wipe up any spilled fuel immediately.**

**IMPORTANT:** Use an approved container to collect and store fuel. Wipe up spilled fuel immediately. Material used to contain spilled fuel must be disposed of in an approved receptacle.

For service on any part of the fuel system:

1. **Before service work:** Stop the engine and disconnect the battery.
2. **During service work:** Perform fuel system service in a well-ventilated area.
3. **After service work:** Inspect all completed service work for signs of fuel leakage.

## Fuel Line Inspection

Visually inspect the fuel line for cracks, swelling, leaks, hardness, or other signs of deterioration or damage. If any of these conditions are found, the fuel line must be replaced.

## Boat-Mounted Fuel Filter

The boat-mounted fuel filter can be serviced as a general maintenance item when the water-in-fuel alarm is activated.

### **⚠ WARNING**

**Fuel is flammable and explosive. Ensure that the key switch is OFF and the lanyard is positioned so that the engine cannot start. Do not smoke or allow sources of spark or open flame in the area while servicing. Keep the work area well ventilated and avoid prolonged exposure to vapors. Always check for leaks before attempting to start the engine, and wipe up any spilled fuel immediately.**

## Removal

**IMPORTANT:** Use an approved container to collect and store fuel. Wipe up spilled fuel immediately. Material used to contain spilled fuel must be disposed of in an approved container.

# MAINTENANCE

1. Verify the ignition key switch is in the **OFF** position and that the lanyard switch is positioned so the engine cannot start.
2. Shut off the fuel supply to the engine.
3. Locate the boat-mounted fuel filter.
4. Disconnect the water-in-fuel (WIF) sensor harness.

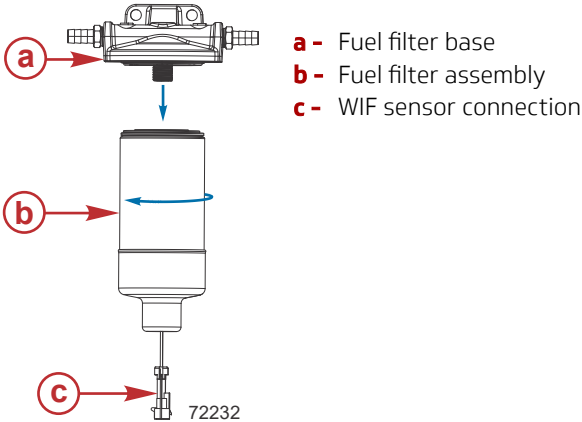

5. Remove the filter assembly from the base by turning counterclockwise.
6. Empty the fuel filter contents into an approved container and dispose according to local regulations.
7. Remove the WIF sensor from the end of the fuel filter and retain for reuse.
  - a. Remove the rubber boot from the bottom of the filter.
  - b. Remove the WIF sensor by turning counterclockwise.

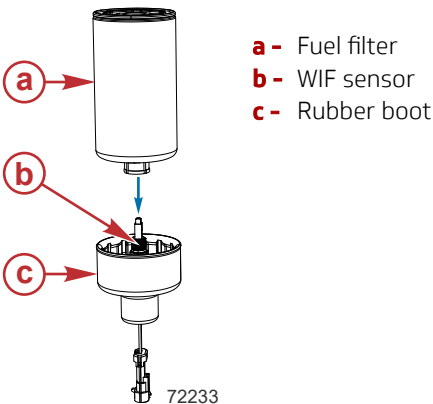

8. Wipe up any spilled fuel.

# MAINTENANCE

## Installation

1. Using a hex wrench, remove the plug from the end of the new fuel filter.
2. Verify that the O-ring is installed on the water-in-fuel (WIF) sensor. Lubricate the O-ring with clean engine oil.

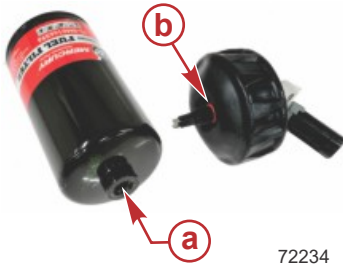

- a - Plug removed
- b - WIF sensor O-ring

72234

3. Thread the WIF sensor clockwise into the fuel filter and tighten to the specified torque.

Description	Nm	lb-in.	lb-ft
Water-in-fuel sensor	2.5	22	-

**NOTE:** Temporarily invert the rubber boot to ease installation.



72235

### WIF sensor installed, rubber boot inverted

4. Push the rubber boot over the WIF sensor until the plastic cap within the boot is fully seated over the WIF sensor. Pull the remainder of the boot over the fuel filter.



72236

### Rubber boot installed

# MAINTENANCE

- Lightly lubricate the fuel filter O-ring with clean engine oil. Thread the fuel filter clockwise onto the fuel filter base until the O-ring makes contact with the base. Then tighten the filter another 2/3–1 turn.

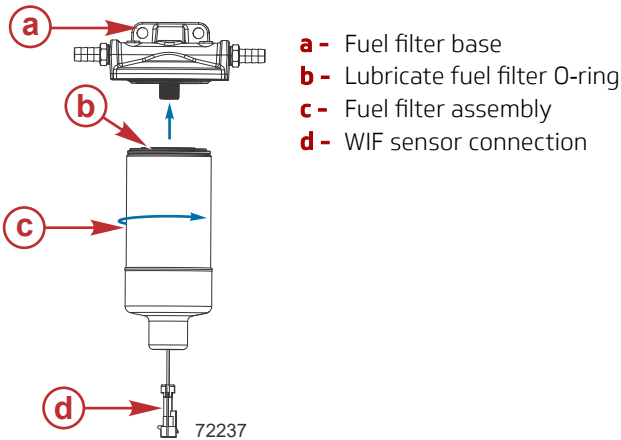

- Connect the water-in-fuel sensor to the fuel filter sensor harness.
- Before starting the engine:
  - Prime the fuel system. Refer to **Filling the Fuel System**.
  - Inspect the installation for fuel leakage. Repair any fuel leaks if necessary.

## Gearcase Lubricant

### Gearcase Lubrication

When adding or changing gearcase lubricant, visually check for the presence of water in the lubricant. If water is present, it may have settled to the bottom and will drain out prior to the lubricant, or it may be mixed with the lubricant, giving it a milky colored appearance. If water is noticed, have the gearcase checked by an authorized dealer. Water in the lubricant may result in premature bearing failure or, in freezing temperatures, will turn to ice and damage the gearcase.

Examine the drained gearcase lubricant for metal particles. A small amount of metal particles indicates normal gear wear. An excessive amount of metal filings or larger particles (chips) may indicate abnormal gear wear and should be checked by an authorized dealer.

### Gearcase Lubricant Capacity

**NOTE:** Gearcase lubricant capacity is approximate.

# MAINTENANCE

<b>Gearcase Lubricant Capacity - V10 350hp and 400hp Verado</b>		
163 mm (6.4 in.)	Right-hand rotation	1580 mL (53.4 fl oz)
	Left-hand rotation	1380 mL (46.7 fl oz)

<b>Gearcase Lubricant Capacity - 400R</b>		
137 mm (5.44 in.) HD	Right-hand rotation	820 mL (27.7 fl oz)
	Left-hand rotation	
Sport Master	Right-hand rotation	620 mL (21.0 fl oz)
	Left-hand rotation	

## Required Gearcase Lubrication

All gearcases are factory filled with SAE 85W-90 Extreme Performance Gear Lube. This lubricant conforms to API GL-4 specifications and should not be mixed with other types of gear lubricant.

<b>Description</b>	<b>Where Used</b>	<b>Part No.</b>
SAE 85W-90 Extreme Performance Gear Lube	All gearcases	8M0111677

## Draining and Filling the Gearcase

### Draining the Gearcase

1. Place the outboard in a vertical operating position.
2. Remove the propeller. Refer to **Propeller Replacement**.
3. Place a pan below the gear housing to capture the lubricant.

# MAINTENANCE

4. Remove the vent plug and fill/drain plug. Allow a sufficient amount of time for the gearcase to drain. Depending on the ambient air temperature, it may take 30 minutes for the gearcase to completely drain.

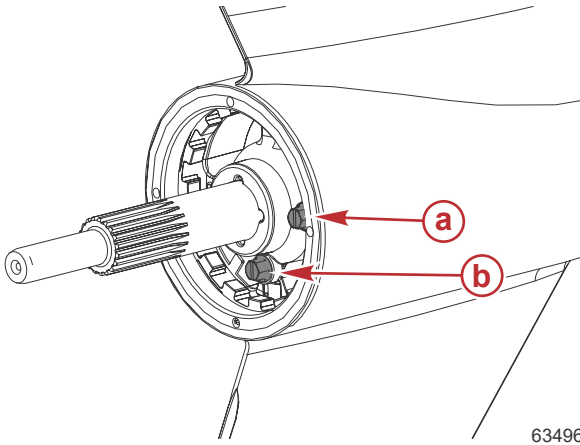

- a** - Vent plug
- b** - Fill/drain plug

## Filling the Gearcase

1. Inspect the fill/drain and vent plug sealing washers for cuts, abrasions, or separation. Replace the washers if damaged.

**IMPORTANT: Never add lubricant to the gearcase without removing the vent plug. The gearcase cannot be filled if the vent plug is not removed because of trapped air. Fill the gearcase only when the gearcase is in a vertical position (driveshaft vertical, propeller shaft horizontal).**

2. Slowly fill the gearcase through the fill hole with the specified gear lubricant until the lubricant flows out of the vent hole and no air bubbles are visible.
3. Allow a few minutes for the lubricant level to stabilize in the gearcase before installing the vent plug. Install the vent plug.

**IMPORTANT: Do not lose more than 15 cc (0.5 fl oz) of gear lubricant while installing the fill plug.**

4. Remove the fill tube or hose from the fill hole and quickly install the fill/drain plug into the fill hole.
5. Tighten the plugs to the specified torque.

Description	Nm	lb-in.	lb-ft
Fill/drain and vent plugs	11.3	100	–

# MAINTENANCE

## Checking Lubricant Level

1. Place the outboard in a vertical operating position. Allow up to 30 minutes for the lubricant level to stabilize in the gear housing.
2. Remove the vent plug. Verify the sealing washer is not adhered to the bearing carrier. The lubricant should be level with the hole or slowly leak from the hole.

### **IMPORTANT: Replace the sealing washers if damaged.**

3. If lubricant is not visible at the vent hole, remove the fill/drain plug and add lubricant until it appears at the vent hole.
4. Install the vent plug.
5. Remove the fill tube or hose from the fill hole and install the fill/drain plug and sealing washer.
6. Tighten the plugs to the specified torque.

Description	Nm	lb-in.	lb-ft
Fill/drain and vent plugs	11.3	100	–

## Checking Power Trim Fluid

1. Tilt outboard to the full up position.
2. Rotate the tilt support bracket down.
3. Lower outboard until tilt support bracket rests on pedestal.
4. Remove the power trim fill cap. The fill cap only requires 1/4 turn to remove.

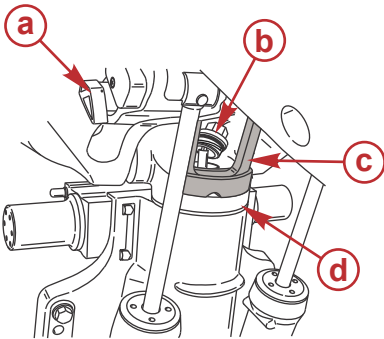

- a** - Tilt support lever
- b** - Power trim fill cap
- c** - Tilt support bracket
- d** - Pedestal

29312

5. The fluid level should be approximately 25 mm (1 in.) from the top of the fill neck. Add Quicksilver or Mercury Precision Lubricants Power Trim and Steering Fluid. If not available, use automotive automatic transmission fluid (ATF).

# MAINTENANCE

Description	Where Used	Part No.
Power Trim and Steering Fluid	Power trim system	92-858074K01

6. Install the power trim fill cap. Tighten fill cap 1/4 turn. Cap will snap in place. Do not tighten beyond this point.

## Propeller Replacement—6.4 Gearcase

### Propeller Removal—Revolution X® Propeller

#### **⚠ WARNING**

**Rotating propellers can cause serious injury or death. Never operate the boat out of the water with a propeller installed. Before installing or removing a propeller, place the drive unit in neutral and activate the lanyard stop switch to prevent the engine from starting. Place a block of wood between the propeller blade and the anti-ventilation plate.**

1. Shift the outboard into the neutral position.
2. Place a block of wood between the gearcase and the propeller to hold the propeller, and remove the propeller nut.

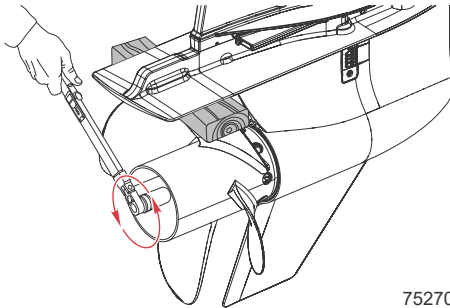

3. Pull the propeller straight off the shaft. If the propeller is seized to the shaft and cannot be removed, have the propeller removed by a Mercury Marine authorized dealer.
4. To aid in future removal of the propeller, liberally coat the propeller shaft splines with Extreme Grease.

Description	Where Used	Part No.
Extreme Grease	Propeller shaft splines	8M0190472

# MAINTENANCE

## Propeller Installation—Revolution X® Propeller

### **⚠ WARNING**

**Rotating propellers can cause serious injury or death. Never operate the boat out of the water with a propeller installed. Before installing or removing a propeller, place the drive unit in neutral and activate the lanyard stop switch to prevent the engine from starting. Place a block of wood between the propeller blade and the anti-ventilation plate.**

**NOTE:** *Verado 350hp and 400hp V10 Models with the Revolution X® propeller require the Flo Torq X® propeller hub kit.*

1. Apply a liberal amount of Extreme Grease to all splined, threaded, and tapered surfaces on the propeller shaft, thrust hub, propeller nut, and propeller hub.

Description	Where Used	Part No.
Extreme Grease	All splined, threaded, and tapered surfaces on the propeller shaft, thrust hub, propeller nut, and propeller hub.	8M0190472

2. Install the thrust washer into the front of the propeller.

**NOTE:** *Inserting the thrust washer into the propeller before installation onto the propeller shaft helps ensure proper engagement between the two items. Even with the application of the Extreme Grease, however, it may still be necessary to hold the washer in position by hand during installation.*

3. Install the propeller hub into the rear of the propeller.
4. Install the propeller assembly (with hub and thrust washer) onto the propeller shaft.

**NOTE:** *Ensure that the propeller remains engaged with the thrust washer.*

5. Install the flat washer onto the propeller shaft.

# MAINTENANCE

6. Install the locknut onto the propeller shaft.

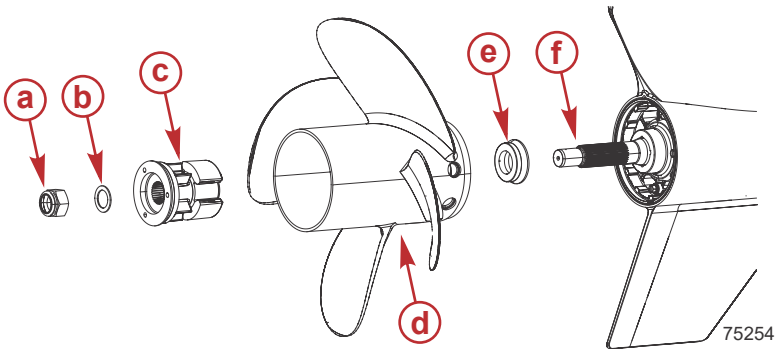

- a** - Locknut
- b** - Flat washer
- c** - Propeller hub
- d** - Propeller
- e** - Thrust washer
- f** - Propeller shaft

7. Place a block of wood between the gearcase and the propeller.

8. Tighten the locknut to the specified torque.

Description	Nm	lb-in.	lb-ft
Locknut	135.6	-	100

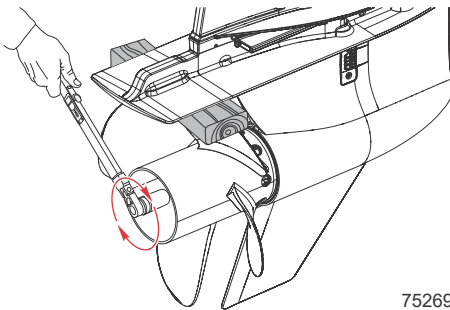

# MAINTENANCE

## Propeller Replacement—5.44 Gearcase

### Propeller Removal—31.75 mm (1-1/4 in.) Diameter Propeller Shaft

#### **⚠ WARNING**

**Rotating propellers can cause serious injury or death. Never operate the boat out of the water with a propeller installed. Before installing or removing a propeller, place the drive unit in neutral and activate the lanyard stop switch to prevent the engine from starting. Place a block of wood between the propeller blade and the anti-ventilation plate.**

1. Shift the outboard into the neutral position.
2. Place a block of wood between the gearcase and the propeller to hold the propeller and remove the propeller nut.

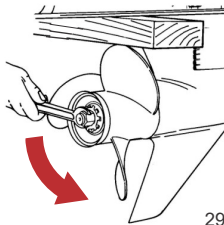

29592

3. Pull the propeller straight off the shaft. If the propeller is seized to the shaft and cannot be removed, have the propeller removed by a Mercury Marine authorized dealer.
4. To aid in future removal of the propeller, liberally coat the propeller shaft splines with Extreme Grease.

Description	Where Used	Part No.
Extreme Grease	Propeller shaft splines	8M0190472

### Propeller Installation—31.75 mm (1-1/4 in.) Diameter Propeller Shaft

#### **⚠ WARNING**

**Rotating propellers can cause serious injury or death. Never operate the boat out of the water with a propeller installed. Before installing or removing a propeller, place the drive unit in neutral and activate the lanyard stop switch to prevent the engine from starting. Place a block of wood between the propeller blade and the anti-ventilation plate.**

**NOTE:** With the exception of CNC Cleaver propellers, all propellers used on the 31.75 mm (1-1/4 in.) diameter propeller shaft require the heavy-duty propeller hub kit.

# MAINTENANCE

1. Apply Extreme Grease to the machined pilot diameter area of the HD propeller hub prior to installation into the propeller.

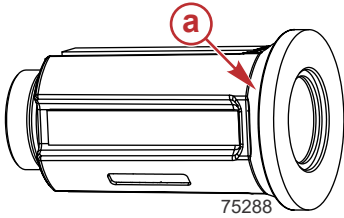

**a** - Machined pilot diameter area

Description	Where Used	Part No.
Extreme Grease	Machined pilot diameter area of propeller hub	8M0190472

2. Install the HD propeller hub into the propeller.

**IMPORTANT: A rubber hammer may be needed to tap the last 6.35–12.7 mm (0.25–0.50 in.) of the hub into the propeller.**

3. Apply Extreme Grease to the propeller shaft splines.

Description	Where Used	Part No.
Extreme Grease	Propeller shaft splines	8M0190472

4. Install the propeller and HD propeller hub onto the propeller shaft.
5. Install the washer onto the propeller shaft.
6. Install the 0.75-16 brass hex nut onto the propeller shaft. Tighten the nut to the specified torque.

Description	Nm	lb-in.	lb-ft
0.75-16 brass hex nut	115.2	–	85

# MAINTENANCE

7. Install the locknut onto the propeller shaft.

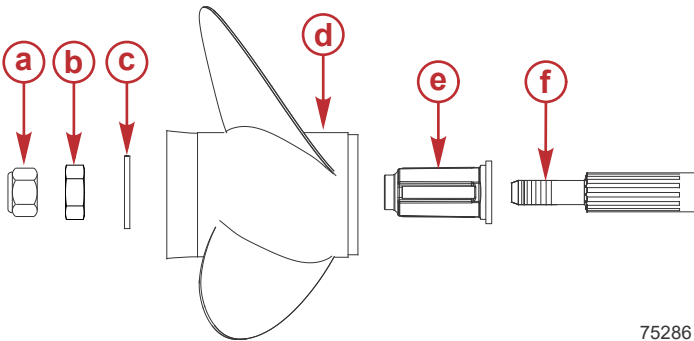

75286

- a** - Propeller locknut
- b** - 0.75-16 brass hex nut
- c** - Washer
- d** - Propeller
- e** - HD propeller hub
- f** - Propeller shaft

8. Place a block of wood between the gearcase and the propeller.

9. Tighten the propeller nut to the specified torque.

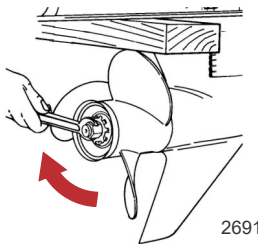

2691

Description	Nm	lb-in.	lb-ft
Locknut	115.2	-	85

## Checking Power Steering Fluid (if Equipped)

### **⚠ WARNING**

**Dirt or contaminants in the hydraulic steering system can damage the steering system's internal components. Damaged components can lead to serious injury or death due to loss of boat control. Do not allow dirt or contamination to enter the helm, lines, or cylinder of this steering system and perform all hydraulic inspections, service, or assembly procedures in a clean work area.**

# MAINTENANCE

1. Remove the power steering pump cover from the enclosure by releasing the straps and lifting the cover.

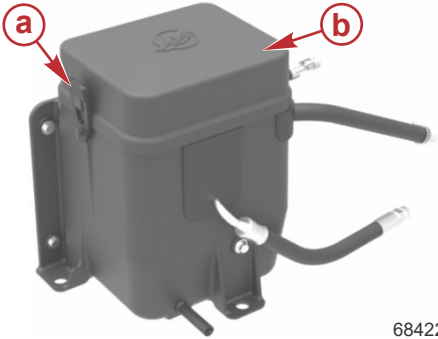

- a - Straps (2)
- b - Power steering pump cover

68422

2. Observe the power steering fluid level inside the reservoir. The fluid level should be between the "MIN" and "MAX" lines on the reservoir.
3. If fluid needs to be added, remove the fill cap from the reservoir and add Synthetic Power Steering Fluid SAE 0W-30 until the fluid level is between the "MIN" and "MAX" lines on the reservoir.

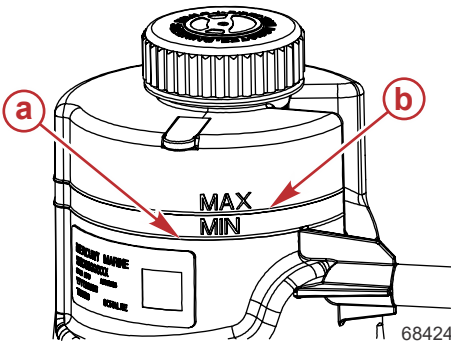

- a - Minimum fluid level
- b - Maximum fluid level

68424

Description	Where Used	Part No.
Synthetic Power Steering Fluid SAE 0W-30	Power steering system	92-858077K01

4. Install the fill cap and install the power steering pump cover. Secure the power steering pump cover with the straps.

## Transom Tightness Inspection

Inspect the outboard for tightness to the boat transom. If any looseness of the outboard or mounting fasteners exist, tighten the outboard mounting fasteners to the specified torque.

# MAINTENANCE

Description	Nm	lb-in.	lb-ft
Outboard mounting locknuts and bolts - standard boat transom	75	–	55.3
Outboard mounting locknuts and bolts - metal lift plates and setback brackets	122	–	90

When looking for signs of looseness, look for loss of outboard transom bracket material or paint caused by movement between the outboard mounting fasteners and the outboard transom brackets. Also look for signs of movement between the outboard transom brackets and the boat transom (lift plate/setback bracket).

## Dealer Service Items

### Accessory Drive Belt

The accessory drive belt is located under the flywheel shroud–intake air induction plenum. The accessory drive belt inspection must be completed by an authorized Mercury dealer at the recommended interval. Refer to **Inspection and Maintenance Schedule**.

### Inline Fuel Filter Inspection

This engine is equipped with an inline fuel filter installed inside the quick-connect fitting near the back of the engine. The filter captures debris that may be in the fuel line after the boat-mounted fuel filtration system. This filter must be inspected and cleaned by an authorized dealer after the first 100 hours of operation.

# MAINTENANCE

Notes:

# STORAGE

## Storage Preparation

The major consideration in preparing an outboard for storage is to protect it from rust, corrosion, and damage caused by the freezing of trapped water.

The following storage procedures should be used to prepare an outboard for out of season storage or prolonged storage (90 days or longer).

## Protecting the Fuel System

### NOTICE

**Without sufficient cooling water, the engine, the water pump, and other components will overheat and suffer damage. Provide a sufficient supply of water to the water inlets during operation.**

**IMPORTANT: Gasoline containing alcohol (ethanol or methanol) can cause a formation of acid during storage and can damage the fuel system. If the gasoline being used contains alcohol, drain as much of the remaining gasoline as possible from the fuel tank, remote fuel line, and engine fuel system.**

Fill the fuel tank and engine fuel system with treated (stabilized) fuel to help prevent formation of varnish and gum. Proceed with the following instructions.

- Portable fuel tank - Pour the required amount of Quickstor Fuel Stabilizer (follow instructions on container) into the fuel tank. Tip the fuel tank back and forth to mix the stabilizer with the fuel.
- Permanently installed fuel tank - Pour the required amount of Quickstor Fuel Stabilizer (follow instructions on container) into a separate container and mix it with approximately 1 liter (1 U.S. quart) of gasoline. Pour this mixture into fuel tank.

Description	Where Used	Part No.
Quickstor Fuel Stabilizer	Fuel tank	92-8M0047932

- Place the outboard in water or connect a flushing attachment for circulating cooling water. Run the engine for ten minutes to fill the engine fuel system.

Flushing Device	91-44357Q 2
	Attaches to the water intakes; provides a fresh water connection when flushing the cooling system or operating the engine.

## Protecting External Outboard Components

- Lubricate all outboard components listed in **Maintenance - Inspection and Maintenance Schedule**.

# STORAGE

- Touch up any paint nicks. See an authorized dealer for touch-up paint.
- Spray Quicksilver or Mercury Precision Lubricants Corrosion Guard on external metal surfaces (except corrosion control anodes).

Description	Where Used	Part No.
Corrosion Guard	External metal surfaces	92-802878 55

## Protecting Internal Engine Components

Contact an authorized Mercury Marine dealer to execute the following:

**IMPORTANT: Refer to the appropriate service manual for spark plug inspection, removal, and replacement procedures.**

- Remove the high tension spark plug leads and spark plugs.
- Spray approximately 30 ml (1 fl oz) of Storage Seal Rust Inhibitor into each spark plug hole.

Description	Where Used	Part No.
Storage Seal Rust Inhibitor	Spark plug holes	92-858081K03

- Actuate key/push button start switch to crank the engine through one start cycle, which will distribute the storage seal throughout the cylinders.
- Install spark plugs and the high tension spark plug leads.

## Engine Fluids

- Change the engine oil and filter. Refer to **Maintenance - Changing Engine Oil and Filter**.
- Change the gearcase lubricant. Refer to **Maintenance - Gearcase Lubricant**.

## Positioning Outboard for Storage

### Out-of-Water Storage Positioning

After removing the boat from the water, store the outboard in an upright (vertical) position to allow water to drain out of the outboard.

# STORAGE

## NOTICE

Storing the outboard in a tilted position can damage the outboard. Water trapped in the cooling passages or rain water collected in the propeller exhaust outlet in the gearcase can freeze. Store the outboard in the full down position.

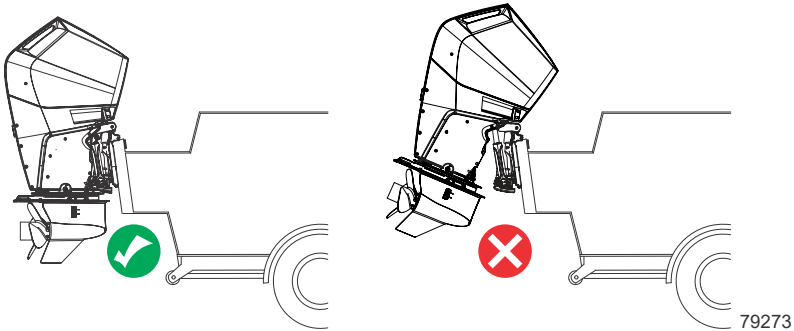

### In-Water Storage Positioning

If the boat is kept moored in the water, tilt the outboard up to its highest position so the gearcase is completely out of the water.

In situations where it is not possible to tilt the gearcase completely out of the water, trim the outboard down to the point that all anodes are submerged. Refer to **Maintenance - Corrosion Control Anodes** for anode locations. This will help protect the outboard against galvanic corrosion by sacrificing the anode metals, rather than the outboard metals.

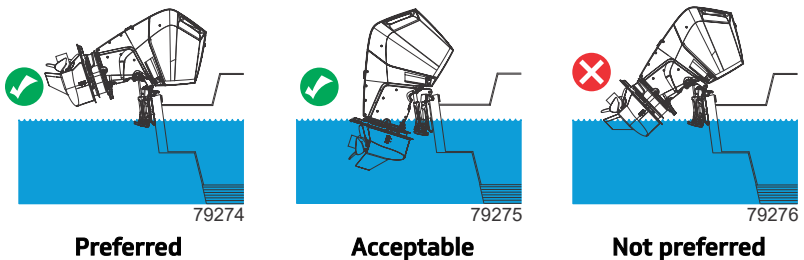

### Battery Storage

- Follow the battery manufacturer's instructions for storage and charging.
- Remove the battery from the boat and check the charge. Charge if necessary.
- Store the battery in a cool, dry place.
- Periodically check the battery voltage during storage. Charge if necessary.

# STORAGE

Notes:

# TROUBLESHOOTING

## DTS Wiring System

### **⚠ WARNING**

**Splicing or probing will damage the wire insulation allowing water to enter the wiring. Water intrusion may lead to wiring failure and loss of throttle and shift control. To avoid the possibility of serious injury or death from loss of boat control, do not splice or probe into any wire insulation of the DTS system.**

- Verify the harnesses are not routed near sharp edges, hot surfaces, or moving parts.
- Verify all unused connectors and receptacles are covered with a weather cap.
- Verify the harnesses are fastened along the routing path.

## Effects of Elevation and Weather on Performance

### Power Robbing Conditions

The following conditions lower engine performance and cannot be compensated by the engine fuel or electronic management systems:

- High elevations
- High ambient temperature
- Low barometric pressure
- High humidity

These conditions reduce the air density to the engine, which in turn lowers the following:

- Boost pressure on supercharged engines
- Horsepower and torque throughout the RPM range
- Peak RPM
- Cranking compression

EXAMPLES: An engine running at an elevation of 2,438 m (8,000 ft) will have over a 30% power loss. A loss of engine power on a hot and humid day could be as much as 14%. These losses apply to normally aspirated and supercharged engines.

### Compensating for Power Robbing Conditions

Some boat performance can be improved by dropping to a lower pitch propeller, but engine performance will still remain lower. To optimize engine performance, prop the engine to allow it to operate at or near the top end of the recommended maximum RPM range at wide-open throttle with a normal boat load.

In some cases, a gear ratio reduction may be more beneficial.

# TROUBLESHOOTING

## Fuses

**IMPORTANT: Always carry spare fuses.**

**IMPORTANT: An ATC fuse has the fuse element enclosed or sealed inside the plastic housing. This type of fuse must be used for marine applications. Marine applications are exposed to environments that may have the potential to accumulate explosive vapors. ATO fuses have exposed elements and should never be used in marine applications.**

The electrical wiring circuits on the outboard are protected from overload with fuses. If a fuse is open, try to locate and correct the cause of the overload. If the cause is not found, the fuse may open again.

### Upper Fuse Panel

The upper fuse panel is equipped with nine fuses. Refer to the following image for identification.

1. Remove the top cowl. Refer to **Maintenance - Top Cowl Removal and Installation**.
2. Locate the fuse holder on the port side of the engine. Remove the cover from the fuse holder.

**NOTE:** A fuse identification decal is located on the fuse panel cover.

3. Remove the suspected open fuse and look at the silver band inside the fuse. If the band is broken (open), replace the fuse.

**IMPORTANT: Replace the fuse with a new fuse with the same amp rating.**

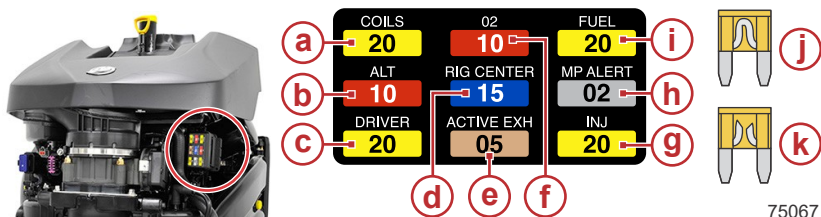

- a - Ignition coils - 20-amp
- b - Alternator - 10-amp
- c - Driver - 20-amp
- d - Rig center - 15-amp
- e - Active exhaust - 5-amp
- f - O2 sensor - 10-amp
- g - Fuel injectors - 20-amp
- h - MP alert - 2-amp
- i - Fuel pump - 20-amp
- j - Good fuse
- k - Open fuse

# TROUBLESHOOTING

## Rig Center Fuse Panel

The rig center fuse panel is equipped with five fuses. Refer to the following image for identification. Four spare fuses are attached to a harness on the inside of the rig center. A 30-amp spare for battery clean power is also included here.

The electrical wiring circuits on the outboard are protected from overload with fuses. If a fuse is open, try to locate and correct the cause of the overload. If the cause is not found, the fuse may open again.

1. Locate the fuse holder on the boat-mounted rig center. Remove the cover from the fuse holder.

**NOTE:** A fuse identification decal is located on the fuse holder cover.

2. Remove the suspected open fuse and look at the silver band inside the fuse. If the band is broken (open), replace the fuse.

**IMPORTANT:** Replace the fuse with a new fuse with the same amp rating.

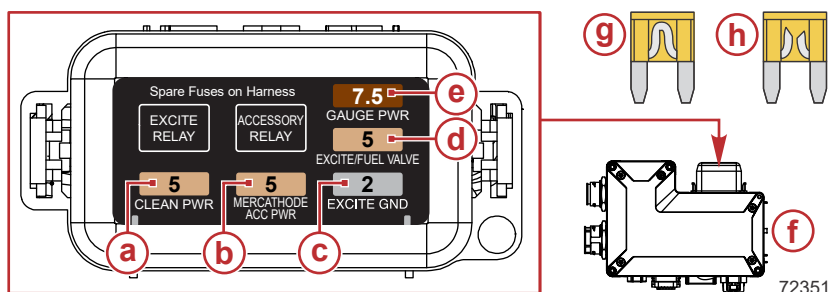

- a** - Clean power - 5-amp
- b** - Mercathode ACC power - 5-amp
- c** - Excite ground - 2-amp
- d** - Excite/fuel valve - 5-amp
- e** - Gauge power - 7.5-amp
- f** - Rig center
- g** - Good fuse
- h** - Open fuse

## Fuses on Rigging Panel

The rigging panel is equipped with three MRBF fuses, and three spares. Refer to the following image for identification.

1. Remove the top cowl. Refer to **Maintenance - Top Cowl Removal and Installation**.

# TROUBLESHOOTING

- Remove the rigging panel cover by pulling outward.



## Rigging panel cover

- Remove the suspected open fuse and look at the silver band inside the fuse. If the band is broken (open), replace the fuse. To remove and replace the fuse:

**IMPORTANT: Replace the fuse with a new fuse with the same amp rating.**

- Remove the nut securing the fuse.
- Remove the fuse.
- Replace the fuse.
- Replace the nut and tighten to the specified torque.

Description	Nm	lb-in.	lb-ft
Fuse nut	12	106	–

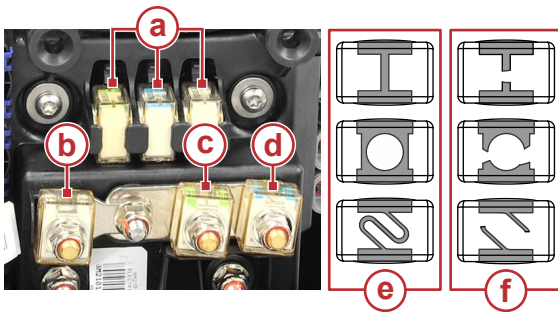

- a** - Spare fuses
- b** - Alternator - 175-amp
- c** - Trim - 80-amp
- d** - Engine harness - 40-amp
- e** - Good fuses
- f** - Open fuses

# TROUBLESHOOTING

## Starter Motor Will Not Crank the Engine

### Possible causes

- Lanyard stop switch not in **RUN** position.
- Open clean power harness circuit fuse. Refer to **Maintenance** section.
- Remote control is not shifted to the neutral position.
- Shift actuator failure. Turn ignition key switch **OFF** to reset and then start the engine.
- Weak battery or battery connections are loose or corroded.
- Ignition key switch failure.
- Wiring or electrical connection faulty.
- Starter motor solenoid or starter relay failure.

## Engine Will Not Start

### Possible causes

- Incorrect starting procedure. Refer to **Operation** section.
- Old or contaminated gasoline.
- Fuel is not reaching the engine.
  - Fuel tank is empty.
  - Fuel tank vent not open or restricted.
  - Fuel line is disconnected or kinked.
  - Fuel filter is obstructed. Refer to **Maintenance** section.
  - Fuel pump failure.
  - Fuel tank filter obstructed.
- Ignition system component failure.
- Spark plugs fouled or defective. Refer to **Maintenance** section.

## Engine Starts But Will Not Shift Into Gear

- Throttle only mode is engaged.
- Shift actuator failure. Turn ignition key switch **OFF** to reset and then start the engine.

## Engine Runs Erratically

### Possible Causes

- Overheating—warning horn not working.
- Low oil pressure. Check oil level.
- Spark plugs fouled or defective. Refer to **Maintenance** section.
- Incorrect setup and adjustments.
- Fuel is being restricted to the engine.

# TROUBLESHOOTING

- Engine fuel filter is obstructed. Refer to **Maintenance** section.
- Fuel tank filter obstructed.
- Stuck anti-siphon valve located on permanently built-in type fuel tanks.
  - Fuel line is kinked or pinched.
- Fuel system is not primed.
- Fuel pump failure.
- Ignition system component failure.

## Performance Loss

### Possible Causes

- Overheating—warning horn not working.
- Low oil pressure. Check oil level.
- Throttle not opening fully.
- Damaged propeller or improper propeller size.
- Low water pressure.
- Low battery voltage.
- Worn, stretched, or broken accessory belt.
- Boat overloaded or load improperly distributed.
- Excessive water in bilge.
- Boat bottom is dirty or damaged.

## Cranking Battery Will Not Hold Charge

### Possible Causes

- Battery connections are loose or corroded.
- Worn out or inefficient battery.
- Excessive use of electrical accessories.
- Defective alternator.
- Open circuit in the alternator fuse circuit on the rigging panel.
- Worn or stretched accessory belt.

# OWNER SERVICE ASSISTANCE

## Identification Records

The serial numbers are the manufacturer's keys to numerous engineering details that apply to a specific Mercury Marine power package. When contacting Mercury Marine about service, **always specify model and serial numbers.**

**Please record the following applicable information:**

Outboard		
<b>Engine Model and Horsepower</b>		
<b>Engine Serial Number</b>		
<b>Gear Ratio</b>		
<b>Propeller Number</b>	<b>Pitch</b>	<b>Diameter</b>
<b>Watercraft Identification Number (WIN) or Hull Identification Number (HIN)</b>		<b>Purchase Date</b>
<b>Boat Manufacturer</b>	<b>Boat Model</b>	<b>Length</b>
<b>Exhaust Gas Emissions Certification Number (Europe Only)</b>		

## Service Assistance

### Local Repair Service

If your Mercury-outboard-powered boat needs service, take it to a Mercury Marine Authorized Dealer. Only authorized dealers specialize in Mercury products and have factory-trained mechanics, special tools and equipment, and genuine Quicksilver parts and accessories to properly service your engine.

**NOTE:** *Quicksilver parts and accessories are engineered and built by Mercury Marine specifically for your power package.*

### Service Away From Home

If you are away from home and the need for service arises, contact the nearest authorized dealer. If, for any reason, you cannot obtain service, contact the nearest Regional Service Center. Outside the United States and Canada, contact the nearest Marine Power International Service Center.

### Stolen Power Package

If your power package is stolen, immediately advise the local authorities and Mercury Marine of the model and serial numbers and to whom the recovery is to be reported. This information is maintained in a database at Mercury Marine to aid authorities and dealers in the recovery of stolen power packages.

# OWNER SERVICE ASSISTANCE

## Attention Required After Submersion

1. Before recovery, contact a Mercury Marine Authorized Dealer.
2. After recovery, immediate service by a Mercury Marine Authorized Dealer is required to reduce the possibility of serious engine damage.

## Replacement Service Parts

### **⚠ WARNING**

**Avoid fire or explosion hazard. Electrical, ignition, and fuel system components on Mercury Marine products comply with federal and international standards to minimize risk of fire or explosion. Do not use replacement electrical or fuel system components that do not comply with these standards. When servicing the electrical and fuel systems, properly install and tighten all components.**

Marine engines are expected to operate at or near full throttle for most of their lives. They are also expected to operate in both fresh and saltwater environments. These conditions require numerous special parts.

## Parts and Accessories Inquiries

Direct any inquiries concerning genuine Mercury Precision Parts® or Quicksilver Marine Parts and Accessories® to a local authorized dealer. Dealers have the proper systems to order parts and accessories, if they are not in stock.

**Engine model** and **serial number** are required to order correct parts.

## Resolving a Problem

Satisfaction with your Mercury Marine product is important to your dealer and to us. If you ever have a problem, question, or concern about your power package, contact your dealer or any Mercury Marine Authorized Dealer. If you need additional assistance:

1. Talk with the dealership's sales manager or service manager.
2. If your question, concern, or problem cannot be resolved by your dealership, please contact the Mercury Marine Service Office for assistance. Mercury Marine will work with you and your dealership to resolve all problems.

The following information will be needed by the Customer Service:

- Your name and address
- Your daytime telephone number
- The model and serial numbers of your power package
- The name and address of your dealership
- The nature of the problem

# OWNER SERVICE ASSISTANCE

## Contact Information for Mercury Marine Customer Service

For assistance, call, fax, or write to the geographic office in your area. Please include your daytime telephone number with mail and fax correspondence.

<b>United States, Canada</b>		
Telephone	English +1 920 929 5040 Français +1 905 636 4751	Mercury Marine W6250 Pioneer Road P.O. Box 1939 Fond du Lac, WI 54936-1939
Fax	English +1 920 929 5893 Français +1 905 636 1704	
Website	www.mercurymarine.com	

<b>Australia, Pacific</b>		
Telephone	+61 3 9791 5822	Brunswick Asia Pacific Group 41-71 Bessemer Drive Dandenong South, Victoria 3175 Australia
Fax	+61 3 9706 7228	

<b>Europe, Middle East, Africa</b>		
Telephone	+32 87 32 32 11	Brunswick Marine in EMEA, LLC Avenue Mercury 8 B-4800 Verviers, Belgium
Email	BME.service@mercmarine.com	

<b>Mexico, Central America, South America, Caribbean</b>		
Telephone	+1 954 744 3500	Mercury Marine 11650 Interchange Circle North Miramar, FL 33025 U.S.A.
Fax	+1 954 744 3535	

<b>Asia, Singapore, Japan</b>		
Telephone	+65 68058100	Mercury Marine Singapore Pte Ltd 11 Changi South Street 3, #01-02 Singapore, 486122
Fax	+65 68058138	

## Ordering Literature

Before ordering literature, have the following information about your power package available:

Model		Serial Number	
Horsepower		Year	

## United States and Canada

For additional literature for your Mercury Marine power package, contact your nearest Mercury Marine dealer or contact:

# OWNER SERVICE ASSISTANCE

<b>Mercury Marine</b>		
<b>Telephone</b>	<b>Fax</b>	<b>Mail</b>
(920) 929-5110	(920) 929-4894	Mercury Marine Attn: Publications Department P.O. Box 1939 Fond du Lac, WI 54936-1939

## Outside the United States and Canada

Contact your nearest Mercury Marine authorized service center to order additional literature that is available for your particular power package.

Submit the following order form with payment to:	Mercury Marine Attn: Publications Department W6250 Pioneer Road P.O. Box 1939 Fond du Lac, WI 54936-1939
--	--

**Ship To: (Copy this form and print or type—This is your shipping label)**

<b>Name</b>	
<b>Address</b>	
<b>City, State, Province</b>	
<b>ZIP or postal code</b>	
<b>Country</b>	

Quantity	Item	Stock Number	Price	Total
			.	.
			.	.
			.	.
			.	.
			.	.
Total Due				.

