

Welcome

You have selected one of the finest outboards available. It incorporates numerous design features to ensure operating ease and durability.

With proper care and maintenance, you will enjoy using this product for many boating seasons. To ensure maximum performance and carefree use, we ask that you thoroughly read this manual.

This manual contains specific instructions for using and maintaining your product. We recommend that this manual remain with the product for ready reference whenever you are on the water.

Thank you for purchasing one of our products. We sincerely hope your boating will be pleasant!

Mercury Marine

EPA Emissions Regulations

Outboards sold by Mercury Marine in the United States are certified to the United States Environmental Protection Agency as conforming to the requirements of the regulations for the control of air pollution from new outboard motors.

This certification is contingent on certain adjustments being set to factory standards. For this reason, the factory procedure for servicing the product must be strictly followed and, wherever practicable, returned to the original intent of the design. Maintenance, replacement, or repair of the emission control devices and systems may be performed by any marine engine repair establishment or individual.

Engines are labeled with an emission control information decal as permanent evidence of EPA certification.

WARNING

The engine exhaust from this product contains chemicals known to the state of California to cause cancer, birth defects or other reproductive harm.

Warranty Message

The product you have purchased comes with a limited warranty from Mercury Marine. The terms of the warranty are set forth in the **Warranty Information** section of this manual. The warranty statement contains a description of what is covered, what is not covered, the duration of coverage, how to best obtain warranty coverage, important disclaimers and limitations of damages, and other related information. Please review this information.

The description and specifications contained herein were in effect at the time this manual was approved for printing. Mercury Marine, whose policy is one of continued improvement, reserves the right to discontinue models at any time, and to change specifications, designs, methods, or procedures without notice and without incurring obligation.

Mercury Marine, Fond du Lac, Wisconsin U.S.A.

Printed in the U.S.A.

© 2013, Mercury Marine

Alpha, Axius, Bravo One, Bravo Two, Bravo Three, Circle M with Waves Logo, K-planes, Mariner, MerCathode, MerCruiser, Mercury, Mercury with Waves Logo, Mercury Marine, Mercury Precision Parts, Mercury Propellers, Mercury Racing, MotorGuide, OptiMax, Quicksilver, SeaCore, Skyhook, SmartCraft, Sport-Jet, Verado, VesselView, Zero Effort, Zeus, and #1 On the Water are registered trademarks of Brunswick Corporation. Mercury Product Protection is a registered service mark of Brunswick Corporation.

Mercury Premier Service

Mercury evaluates the service performance of its dealers and assigns its highest rating of Mercury Premier to those demonstrating an exceptional commitment to service.

Earning a Mercury Premier Service rating means a dealer:

- Achieves a high 12-month service Customer Satisfaction Index (CSI) score for warranty service.
- Possesses all of the necessary service tools, test equipment, manuals, and parts books.
- Employs at least one certified or master technician.

- Provides timely service for all Mercury Marine customers.
- Offers extended service hours and mobile service, when appropriate.
- Uses, displays, and stocks an adequate inventory of genuine Mercury Precision Parts.
- Offers a clean, neat shop with well-organized tools and service literature.

WARRANTY INFORMATION

Warranty Registration United States And Canada.....	1
Transfer of Warranty United States and Canada.....	2
Mercury Racing JP5 Outboard Limited Warranty (Government and Commercial Usage).....	2
Products Sold to Government Agencies.....	6
Three Year Limited Warranty Against Corrosion.....	6
Warranty Coverage and Exclusions for Mercury Racing Outboard Products.....	10
U.S. EPA Emissions Limited Warranty.....	11
Emission Control System Components.....	11
Warranty Policy—Australia and New Zealand.....	13

General Information

Boater's Responsibilities.....	19
Before Operating Your Outboard.....	19
Boat Horsepower Capacity.....	19
High-Speed and High-Performance Boat Operation.....	20
Outboard Remote Control Models	20
Remote Steering Notice.....	21
Lanyard Stop Switch.....	22
Protecting People in the Water.....	23
Exhaust Emissions.....	24
Passenger Safety Message - Pontoon Boats and Deck Boats	27
Wave and Wake Jumping.....	28
Impact with Underwater Hazards.....	29
Selecting Accessories for Your Outboard.....	30
Safe Boating Recommendations.....	31
Recording Serial Number.....	34
Component Identification.....	35
General Specifications OptiMax JP.....	35
Propeller Selection.....	37

Transporting

Trailer Boat/Outboard	38
-----------------------------	----

Fuel and Oil

Fuel Requirements.....	39
Oil Requirement.....	39
Fuel Additives.....	39
Avoiding Fuel Flow Restrictions.....	40
Low Permeation Fuel Hose Requirement	40
EPA Pressurized Portable Fuel Tank Requirements.....	40
Fuel Demand Valve (FDV) Requirement.....	40
Mercury Marine's Pressurized Portable Fuel Tank.....	41
Filling Remote Oil Tank.....	42
Filling Engine Mounted Oil Reservoir Tank.....	43
Filling Fuel Tank.....	43

Features and Controls

Remote Control Features.....	45
Zero Effort Control Features.....	46
Warning System.....	46
Power Trim and Tilt.....	49

Operation

Important Information.....	55
Engine Break-in.....	56
Engine Break-in Fuel Mixture.....	57
Prestarting Check List.....	57
Operating in Freezing Temperatures.....	57
Operating in Saltwater or Polluted Water.....	57
Operating at High Elevations.....	58
Effects of Elevation and Weather on Performance.....	58
Setting Trim Angle While Running Engine at Idle Speed.....	59
Operating in Shallow Water.....	59
Starting The Engine.....	60
Gear Shifting.....	63
Stopping the Engine.....	64

Maintenance

Power Package Care.....	65
Submerged Power Package.....	65
Replacement Parts for Your Power Package.....	65
EPA Emissions Regulations.....	66
Inspection And Maintenance Schedule.....	67
Flushing the Cooling System (Powerhead).....	70
Flushing the Cooling System (Lower Unit).....	71
Top Cowl Removal and Installation.....	72
Cleaning Care for Top Cowl.....	72
Fuel System.....	73
Steering Link Rod Fasteners.....	76
Fuses	78
Corrosion Control Anode.....	79
Spark Plug Inspection and Replacement.....	80
Battery Inspection	81
Charging System Fusible Link.....	82
Replacing the Propeller.....	82
Lubrication Points.....	85
Checking Power Trim Fluid (Three-Ram Trim Systems).....	87
Gearcase Lubricant.....	88

Storage

Protecting External Outboard Components.....	90
Gearcase.....	90
Positioning Outboard for Storage.....	90
Battery Storage.....	90

Troubleshooting

Starter Motor Will Not Crank the Engine.....	91
Engine Will Not Start.....	91
Engine Runs Erratically.....	92
Performance Loss.....	92
Warning Horn Activates (With Power Loss).....	92
Warning Horn Activates (No Power Loss).....	93
Battery Will Not Hold Charge.....	93

Owner Service Assistance

Local Repair Service.....	95
Service Away from Home.....	95
Parts and Accessories Inquiries.....	95
Service Assistance.....	95
Ordering Literature.....	98

Outboard Installation

Mercury Marine Validated Engine Mounting Hardware.....	100
Boat Horsepower Capacity.....	101
Start in Gear Protection.....	101
Selecting Accessories for Your Outboard.....	101
Fuel System.....	102
Installation Specifications.....	104
Lifting the Outboard.....	104
Steering Cable - Starboard Side Routed Cable.....	105
Steering Link Rod Fasteners.....	106
Recommended Mounting Height.....	109
Drilling Outboard Mounting Holes.....	110
Fastening the Outboard to the Transom.....	111
Electrical, Hoses, Control Cables, and Front Clamp.....	117
Oil Injection Set-Up.....	130
Trim In Pin.....	133

Maintenance Log

Maintenance Log.....	135
----------------------	-----

WARRANTY INFORMATION

Warranty Registration United States And Canada

Outside United States and Canada - Check with your local distributor.

1. You may change your address at any time, including at time of warranty claim, by calling Mercury Marine or sending a letter or fax with your name, old address, new address, and engine serial number to Mercury Marine's warranty registration department. Your dealer can also process this change of information.

Mercury Marine

Attn.: Warranty Registration Department

W6250 W. Pioneer Road

P.O. Box 1939

Fond du Lac, WI 54936-1939

920-929-5054

Fax 920-907-6663

NOTE: Registration lists must be maintained by Mercury Marine and any dealer on marine products sold in the United States, should a safety recall notification under the Federal Safety Act be required.

2. At the time of sale, the dealer should complete the warranty registration and immediately submit it to Mercury Marine via MercNET, E-mail, or mail. Upon receipt of this warranty registration, Mercury Marine will record the registration.

IMPORTANT: Your warranty coverage begins at the time of sale, but warranty claims cannot be processed until the product is registered with Mercury Marine.

3. Upon processing the warranty registration, Mercury Marine will send the purchaser a Mercury Owner Resource Guide. The back page of this guide contains your warranty registration information and should be saved. If this registration verification is not received within 30 days, please contact your selling dealer immediately.

WARRANTY INFORMATION

Transfer of Warranty United States and Canada

The limited warranty is transferable to a subsequent purchaser, but only for the remainder of the unused portion of the limited warranty. This will not apply to products used for commercial applications.

To transfer the warranty to the subsequent owner, send or fax a copy of the bill of sale or purchase agreement, new owner's name, address, and engine serial number to Mercury Marine's warranty registration department. In the United States and Canada, mail to:

Mercury Marine
Attn: Warranty Registration Department
W6250 W. Pioneer Road
P.O. Box 1939
Fond du Lac, WI 54936-1939
920-929-5054
Fax +1 920 907 6663

Upon processing the transfer of warranty, Mercury Marine will record the new owner's information.

There is no charge for this service.

OUTSIDE THE UNITED STATES AND CANADA

For products purchased outside the United States and Canada, contact the distributor in your country, or the Marine Power Service Center closest to you.

Mercury Racing JP5 Outboard Limited Warranty (Government and Commercial Usage)

WHAT IS COVERED

Mercury Marine warrants its new JP5 Outboard products to be free of defects in material and workmanship during the period described below.

WARRANTY INFORMATION

DURATION/DESCRIPTION OF COVERAGE

This Limited Warranty provides coverage for two (2) years from the date the product is first sold to an authorized governmental agency, or the date on which the product is first put into service, whichever occurs first. Commercial users of these products receive warranty coverage of one (1) year from the date of first retail sale, or one (1) year from the date on which the product was first put into service, whichever occurs first. Commercial use is defined as any work or employment related use of the product, or any use of the product which generates income, for any part of the warranty period, even if the product is only occasionally used for such purposes. The repair or replacement of parts, or the performance of service under this warranty, does not extend the life of this warranty beyond its original expiration date. Unexpired warranty coverage cannot be transferred to a subsequent purchaser.

CONDITIONS THAT MUST BE MET IN ORDER TO OBTAIN WARRANTY COVERAGE

Warranty coverage is available only to governmental agencies or commercial customers that purchase from a dealer authorized by Mercury Marine to distribute the product in the country in which the sale occurred, and then only after the Mercury Marine specified pre-delivery inspection process is completed and documented. Warranty coverage becomes available upon proper registration of the product. Routine maintenance as defined by the **Maintenance Schedule**, as outlined in the **Operation, Maintenance and Warranty Manual**, must be timely performed in order to maintain warranty coverage. Mercury Marine reserves the right to make future warranty coverage contingent on proof of proper maintenance.

WARRANTY INFORMATION

WHAT MERCURY WILL DO

Mercury's sole and exclusive obligation under this warranty is limited to, at our option, repairing a defective part, replacing such part or parts with new or Mercury Marine certified re-manufactured parts, or refunding the purchase price of the Mercury product. Mercury reserves the right to improve or modify products from time to time without assuming an obligation to modify products previously manufactured.

HOW TO OBTAIN WARRANTY COVERAGE

The customer must provide Mercury with a reasonable opportunity to repair, and reasonable access to the product for warranty service. Warranty claims shall be made by delivering the product for inspection to a Mercury dealer authorized to service the product. If purchaser cannot deliver the product to such a dealer, written notice must be given to Mercury. We will then arrange for the inspection and any covered repair. Purchaser in that case shall pay for all related transportation charges and/or travel time. If the service provided is not covered by this warranty, purchaser shall pay for all related labor and material, and any other expenses associated with that service. Purchaser shall not, unless requested by Mercury, ship the product or parts of the product directly to Mercury. Proof of registered ownership must be presented to the dealer at the time warranty service is requested in order to obtain coverage.

WARRANTY INFORMATION

WHAT IS NOT COVERED

This limited warranty does not cover routine maintenance items, tune ups, adjustments, normal wear and tear, damage caused by abuse, abnormal use, use of a propeller or gear ratio that does not allow the engine to run in its recommended wide open throttle RPM range (refer to the **Operation and Maintenance Manual**), operation of the product in a manner inconsistent with the recommended operation/duty cycle section of the Operation and Maintenance Manual, neglect, accident, submersion, improper installation (proper installation specifications and techniques are set forth in the installation instructions for the product), improper service, use of an accessory or part not manufactured or sold by us, jet pump impellers and wear rings or liners, operation with fuels, oils or lubricants which are not suitable for use with the product (refer to the **Operation and Maintenance Manual**), alteration or removal of parts, water entering the engine through the fuel intake, air intake or exhaust system, damage to the product from insufficient cooling water caused by blockage of the cooling system by a foreign body, or running the engine out of water. Use of the product for racing or other competitive activity, or operating with racing modifications, at any point, even by a prior owner of the product, voids the warranty.

Expenses related to haul-out, launch, towing, storage, telephone, rental, inconvenience, slip fees, insurance coverage, loan payments, loss of time, loss of income, or any other type of incidental or consequential damages are not covered by this warranty. Also, expenses associated with the removal and/or replacement of boat partitions or material caused by boat design for access to the product are not covered by this warranty.

No individual or entity, including Mercury Marine authorized dealers, has been given authority by Mercury Marine to make any affirmation, representation or warranty regarding the product, other than those contained in this limited warranty, and if made, shall not be enforceable against Mercury Marine.

WARRANTY INFORMATION

For additional information regarding events and circumstances covered by this warranty, and those that are not, refer to the **Warranty Coverage** section of the **Operation and Maintenance Manual**, incorporated by reference into this warranty.

DISCLAIMERS AND LIMITATIONS

THE IMPLIED WARRANTIES OF MERCHANTABILITY AND FITNESS FOR A PARTICULAR PURPOSE ARE EXPRESSLY DISCLAIMED. TO THE EXTENT THAT THEY CANNOT BE DISCLAIMED, THE IMPLIED WARRANTIES ARE LIMITED IN DURATION TO THE LIFE OF THE EXPRESS WARRANTY. INCIDENTAL AND CONSEQUENTIAL DAMAGES ARE EXCLUDED FROM COVERAGE UNDER THIS WARRANTY. SOME STATES/COUNTRIES DO NOT ALLOW FOR THE DISCLAIMERS, LIMITATIONS AND EXCLUSIONS IDENTIFIED ABOVE, AS A RESULT, THEY MAY NOT APPLY TO YOU. THIS WARRANTY GIVES YOU SPECIFIC LEGAL RIGHTS, AND YOU MAY ALSO HAVE OTHER LEGAL RIGHTS WHICH VARY FROM STATE TO STATE AND COUNTRY TO COUNTRY.

Products Sold to Government Agencies

Contact the Mercury Racing Sales Department for a copy of the Government Agencies Warranty Packet Kit which explains the conditions required for government agencies to receive warranty when purchasing Mercury Racing Outboard or Sterndrive product.

Mercury Racing Sales Department
N7840 County Road UU
Fond du Lac, WI 54935
920-921-5330
Fax 920-921-6533

Three Year Limited Warranty Against Corrosion

WHAT IS COVERED: Mercury Marine warrants that each new Mercury, Mariner, Mercury Racing Outboard, Sport Jet, M² Jet Drive, Tracker by Mercury Marine Outboard, Mercury MerCruiser Inboard or Sterndrive Engine, Mercury Racing Bravo style sterndrive engine (Product) will not be rendered inoperative as a direct result of corrosion for the period of time described below.

WARRANTY INFORMATION

DURATION OF COVERAGE: This limited corrosion warranty provides coverage for three (3) years from either the date the product is first sold, or the date on which the product is first put into service, whichever occurs first. The repair or replacement of parts, or the performance of service under this warranty does not extend the life of this warranty beyond its original expiration date. Unexpired warranty coverage can be transferred to subsequent (non-commercial use) purchaser upon proper re-registration of the product.

CONDITIONS THAT MUST BE MET IN ORDER TO OBTAIN WARRANTY COVERAGE: Warranty coverage is available only to retail customers that purchase from a dealer authorized by Mercury Marine to distribute the product in the country in which the sale occurred, and then only after the Mercury Marine specified pre-delivery inspection process is completed and documented. Warranty coverage becomes available upon proper registration of the product by the authorized dealer. Corrosion prevention devices specified in the Operation and Maintenance Manual must be in use on the boat, and routine maintenance outlined in the Operation and Maintenance Manual must be timely performed (including without limitation the replacement of sacrificial anodes, use of specified lubricants, and touch-up of nicks and scratches) in order to maintain warranty coverage. Mercury Marine reserves the right to make warranty coverage contingent upon proof of proper maintenance.

WHAT MERCURY WILL DO: Mercury's sole and exclusive obligation under this warranty is limited to, at our option, repairing a corroded part, replacing such part or parts with new or Mercury Marine certified re-manufactured parts, or refunding the purchase price of the Mercury product. Mercury reserves the right to improve or modify products from time to time without assuming an obligation to modify products previously manufactured.

WARRANTY INFORMATION

HOW TO OBTAIN WARRANTY COVERAGE: The customer must provide Mercury with a reasonable opportunity to repair, and reasonable access to the product for warranty service. Warranty claims shall be made by delivering the product for inspection to a Mercury dealer authorized to service the product. If purchaser cannot deliver the product to such a dealer, written notice must be given to Mercury. We will then arrange for the inspection and any covered repair. Purchaser in that case shall pay for all related transportation charges and/or travel time. If the service provided is not covered by this warranty, purchaser shall pay for all related labor and material, and any other expenses associated with that service. Purchaser shall not, unless requested by Mercury, ship the product or parts of the product directly to Mercury. Proof of registered ownership must be presented to the dealer at the time warranty service is requested in order to obtain coverage.

WHAT IS NOT COVERED: This limited warranty does not cover electrical system corrosion; corrosion resulting from damage, corrosion which causes purely cosmetic damage, abuse or improper service; corrosion to accessories, instruments, steering systems; corrosion to factory installed jet drive unit; damage due to marine growth; replacement parts (parts purchased by customer); products used in a commercial application. Commercial use is defined as any work or employment related use of the product, or any use of the product which generates income, for any part of the warranty period, even if the product is only occasionally used for such purposes.

WARRANTY INFORMATION

Corrosion damage caused by stray electrical currents (on-shore power connections, nearby boats, submerged metal) is not covered by this corrosion warranty and should be protected against by the use of a corrosion protection system, such as the Mercury Precision Parts or Quicksilver MerCathode system and/or Galvanic Isolator. Corrosion damage caused by improper application of copper base anti-fouling paints is also not covered by this limited warranty. If anti-fouling protection is required, tri-butyl-tin-adipate (TBTA) base anti-fouling paints are recommended on Outboard and MerCruiser boating applications. In areas where TBTA base paints are prohibited by law, copper base paints can be used on the hull and transom. Do not apply paint to the outboard or MerCruiser product. In addition, care must be taken to avoid an electrical interconnection between the warranted product and the paint. For MerCruiser product, an unpainted gap of at least 38 mm (1.5 in.) should be left around the transom assembly. Refer to the **Operation and Maintenance Manual** for additional details.

For additional information regarding events and circumstances covered by this warranty, and those that are not, see the Warranty Coverage section of the **Operation and Maintenance Manual**, incorporated by reference into this warranty.

DISCLAIMERS AND LIMITATIONS:

THE IMPLIED WARRANTIES OF MERCHANTABILITY AND FITNESS FOR A PARTICULAR PURPOSE ARE EXPRESSLY DISCLAIMED. TO THE EXTENT THAT THEY CANNOT BE DISCLAIMED, THE IMPLIED WARRANTIES ARE LIMITED IN DURATION TO THE LIFE OF THE EXPRESS WARRANTY. INCIDENTAL AND CONSEQUENTIAL DAMAGES ARE EXCLUDED FROM COVERAGE UNDER THIS WARRANTY. SOME STATES/COUNTRIES DO NOT ALLOW FOR THE DISCLAIMERS, LIMITATIONS AND EXCLUSIONS IDENTIFIED ABOVE, AS A RESULT, THEY MAY NOT APPLY TO YOU. THIS WARRANTY GIVES YOU SPECIFIC LEGAL RIGHTS, AND YOU MAY ALSO HAVE OTHER LEGAL RIGHTS WHICH VARY FROM STATE TO STATE AND COUNTRY TO COUNTRY.

WARRANTY INFORMATION

Warranty Coverage and Exclusions for Mercury Racing Outboard Products

The purpose of this section is to help eliminate some of the more common misunderstandings regarding warranty coverage. The following information explains some of the types of services that are not covered by warranty. The provisions set forth following have been incorporated by reference into the Mercury Racing Division Three Year Limited Warranty Against Corrosion Failure, the Mercury Racing Division One and Two Year Limited Warranties.

Keep in mind that warranty covers repairs that are needed within the warranty period because of defects in material and workmanship. Installation errors, accidents, normal wear, and a variety of other causes that affect the product are not covered.

Warranty is limited to defects in material or workmanship, but only to retail customers that purchase from a dealer authorized by Mercury Marine to distribute the product in the country in which the sale occurred, and then only after the Mercury Marine specified pre-delivery inspection process is completed and documented.

Should you have any questions concerning warranty coverage, contact your authorized dealer. They will be pleased to answer any questions that you may have.

GENERAL EXCLUSIONS FROM WARRANTY

1. Minor adjustments and tune-ups, including checking, cleaning or adjusting spark plugs, ignition components, carburetor or EFI settings, filters, belts, controls, and checking lubrication made in connection with normal services.
2. Damage caused by lack of maintenance.
3. Haul-out, launch, towing charges, and all related transportation charges and/or travel time, etc.
4. Additional service work requested by customer other than that necessary to satisfy the warranty obligation.

WARRANTY INFORMATION

5. Labor performed by other than an authorized dealer may be covered only under following circumstances: When performed on emergency basis (providing there are no authorized dealers in the area who can perform the work required or have no facilities to haul out, etc., and prior factory approval has been given to have the work performed at this facility).
6. Use of other than Mercury Precision or Quicksilver parts when making warranty repairs.
7. Engine noise does not necessarily indicate a serious engine problem. If diagnosis indicates a serious internal engine condition, which could result in a failure, condition responsible for noise should be corrected under the warranty.
8. Lower unit and/or propeller damage caused by striking a submerged object is considered a marine hazard.
9. Water in the starter motor.
10. Starter motors and/or armatures or field coil assembly, which are burned, or where lead is thrown out of commutator because of excess cranking.
11. Valve or valve seat grinding required because of wear.

U.S. EPA Emissions Limited Warranty

Consistent with the obligations created by 40 CFR Part 1045, Subpart B, Mercury Marine provides a five year or 175 hours of engine use, whichever occurs first, to the retail customer, that the engine is designed, built, and equipped so as to conform at the time of sale with applicable regulations under section 213 of the Clean Air Act, and that the engine is free from defects in materials and workmanship which cause the engine to fail to conform with applicable regulations. This emission-related warranty covers all the components listed in the **Emission Control System Components**.

Emission Control System Components

The EPA emission-related warranty covers all the following list of components:

WARRANTY INFORMATION

COMPONENTS OF THE EMISSIONS CONTROL SYSTEM:

1. Fuel metering system
 - a. Carburetor and internal parts (and/or pressure regulator or fuel injection system)
 - b. Cold start enrichment system
 - c. Intake valves
2. Air induction system
 - a. Intake manifold
 - b. Turbocharger or supercharger systems (where applicable)
3. Ignition system
 - a. Spark plugs
 - b. Magneto or electronic ignition system
 - c. Spark advance/retard system
 - d. Ignition coil and/or control module
 - e. Ignition wires
4. Lubrication system (4-Stroke engines excluded)
 - a. Oil pump and internal parts
 - b. Oil injectors
 - c. Oil meter
5. Exhaust system
 - a. Exhaust manifold
 - b. Exhaust valves
6. Miscellaneous items used in above systems
 - a. Hoses, clamps, fittings, tubing, sealing gaskets or devices, and mounting hardware
 - b. Pulleys, belts, and idlers
 - c. Vacuum, temperature, check and time sensitive valves and switches
 - d. Electronic controls

The emission-related warranty does not cover components whose failure would not increase an engine's emissions on any regulated pollutant.

WARRANTY INFORMATION

Warranty Policy—Australia and New Zealand

MERCURY/MARINER OUTBOARD LIMITED WARRANTY—AUSTRALIA AND NEW ZEALAND POLICY

This limited warranty is given by Marine Power International Pty Ltd ACN 003 100 007 of 41–71 Bessemer Drive, Dandenong South, Victoria 3175 Australia (telephone (61) (3) 9791 5822) e-mail: merc_info@mercmarine.com.

What is Covered

Mercury Marine warrants its new products to be free of defects in material and workmanship during the period described below. The benefits to the consumer given by the warranty are in addition to other rights and remedies of the consumer under a law in relation to the goods or services to which the warranty relates.

Guarantees Under Australian Consumer Law

Our goods come with guarantees that cannot be excluded under the Australian Consumer Law. You are entitled to a replacement or refund for a major failure and compensation for any other reasonably foreseeable loss or damage. You are also entitled to have the goods repaired or replaced if the goods fail to be of acceptable quality and the failure does not amount to a major failure.

Warranty Period for Recreational Use

This Limited Warranty provides coverage for three (3) years from the date the product is first sold to a recreational use retail purchaser, or the date on which the product is first put into service, whichever occurs first. Unexpired warranty coverage can be transferred to a subsequent recreational use customer upon proper registration of the product.

WARRANTY INFORMATION

Warranty Period for Commercial Use

Commercial users of these products receive warranty coverage under this Limited Warranty of one (1) year from the date of first retail sale, or one (1) year from the date on which the product was first put into service, whichever occurs first. Commercial use is defined as any work or employment related use of the product, or any use of the product which generates income, for any part of the warranty period, even if the product is only occasionally used for such purposes. Unexpired warranty coverage cannot be transferred either to or from a commercial use customer.

Conditions That Must Be Met to Obtain Warranty Coverage

Warranty coverage under this Limited Warranty is available only to retail customers that purchase from a Dealer authorized by Mercury Marine to distribute the product in the country in which the sale occurred, and then only after the Mercury Marine specified predelivery inspection process is completed and documented. Warranty coverage becomes available upon proper registration of the product by the authorized dealer. Inaccurate warranty registration information regarding recreational use, or subsequent change of use from recreational to commercial (unless properly registered) may void the warranty at the sole discretion of Mercury Marine. Routine maintenance outlined in the Operation and Maintenance Manual must be timely performed in order to maintain warranty coverage. Mercury Marine reserves the right to make warranty coverage contingent upon proof of proper maintenance.

What Mercury Will Do

Mercury Marine's sole and exclusive obligation under this Limited Warranty is limited to, at our option, repairing a defective part, replacing such part or parts with new or Mercury Marine certified remanufactured parts, or refunding the purchase price of the Mercury Marine product. Mercury Marine reserves the right to improve or modify products from time to time without assuming an obligation to modify products previously manufactured.

WARRANTY INFORMATION

How to Obtain Warranty Coverage Under This Limited Warranty

The customer must provide Mercury Marine with a reasonable opportunity to repair and reasonable access to the product for warranty service. Warranty claims shall be made by delivering the product for inspection to a Mercury Marine dealer authorized to service the product. A list of dealers and their contact details is available at www.mercurymarine.com.au. If the purchaser cannot deliver the product to such a dealer, written notice must be given to Mercury Marine at the address shown above. Mercury Marine will then arrange for the inspection and any covered repair. This Limited Warranty will not cover the purchaser for all related transportation charges and travel time. If the service provided is not covered by this limited warranty, the purchaser shall pay for all related labor and material and any other expenses associated with that service, provided that a consumer will not be obligated to pay where the service has been carried out to remedy a failure of an acceptable quality guarantee which is binding on Mercury Marine under the Australian Consumer Law. The purchaser shall not, unless requested by Mercury Marine, ship the product or parts of the product directly to Mercury Marine. Proof of registered ownership must be presented to the dealer at the time warranty service is requested in order to obtain coverage under this Limited Warranty.

WARRANTY INFORMATION

What is Not Covered

This limited warranty does not cover routine maintenance items, tune-ups, adjustments, normal wear and tear, damage caused by abuse, abnormal use, use of a propeller or gear ratio that does not allow the engine to run in its recommended wide-open throttle RPM range (see the Operation and Maintenance Manual), operation of the product in a manner inconsistent with the recommended operation/duty cycle section of the Operation and Maintenance Manual, neglect, accident, submersion, improper installation (proper installation specifications and techniques are set forth in the installation instructions for the product), improper service, use of an accessory or part not manufactured or sold by us, jet pump impellers and liners, operation with fuels, oils or lubricants which are not suitable for use with the product (see the Operation and Maintenance Manual), alteration or removal of parts, water entering the engine through the fuel intake, air intake or exhaust system, or damage to the product from insufficient cooling water caused by blockage of the cooling system by a foreign body, running the engine out of water, mounting the engine too high on the transom, or running the boat with the engine trimmed out too far. Use of the product for racing or other competitive activity, or operating with a racing type lower unit, at any point, even by a prior owner of the product, voids the warranty.

Expenses related to haul-out, launch, towing, storage, telephone, rental, inconvenience, slip fees, insurance coverage, loan payments, loss of time, loss of income, or any other type of incidental or consequential damages are not covered by this Limited Warranty. Also, expenses associated with the removal and/or replacement of boat partitions or material caused by boat design for access to the product are not covered by this warranty.

WARRANTY INFORMATION

No individual or entity, including Mercury Marine authorized dealers, has been given authority by Mercury Marine to make any affirmation, representation or warranty regarding the product, other than those contained in this limited warranty, and if made, shall not be enforceable against Mercury Marine. For additional information regarding events and circumstances covered by this warranty, and those that are not, see the Warranty Coverage section of the Operation and Maintenance Manual, incorporated by reference into this warranty.

Expense of Claiming This Limited Warranty

This Limited Warranty does not cover any expenses you may incur claiming the warranty.

DISCLAIMERS AND LIMITATIONS:
EXCEPT FOR APPLICABLE GUARANTEES AND OTHER RIGHTS AND REMEDIES THAT A CONSUMER MAY HAVE UNDER THE AUSTRALIAN CONSUMER LAW OR OTHER LAW IN RELATION TO WHICH THE PRODUCTS RELATE, THE IMPLIED WARRANTIES OF MERCHANTABILITY AND FITNESS FOR A PARTICULAR PURPOSE ARE EXPRESSLY DISCLAIMED. TO THE EXTENT THAT THEY CANNOT BE DISCLAIMED, THE IMPLIED WARRANTIES ARE LIMITED IN DURATION TO THE LIFE OF THE EXPRESS WARRANTY. INCIDENTAL AND CONSEQUENTIAL DAMAGES ARE EXCLUDED FROM COVERAGE UNDER THIS LIMITED WARRANTY.

TRANSFER OF WARRANTY—AUSTRALIA AND NEW ZEALAND POLICY

The limited warranty is transferable to a subsequent purchaser, but only for the remainder of the unused portion of the limited warranty. This will not apply to products used for commercial applications.

To transfer the warranty to the subsequent owner, send or fax a copy of the Bill of Sale or Purchase Agreement, new owner's name, address, and hull identification number (HIN) to Mercury Marine's Warranty Registration Department. In Australia and New Zealand, mail to:

WARRANTY INFORMATION

Mercury Marine
Attn: Warranty Registration Department
Brunswick Asia Pacific Group
Private Bag 1420
Dandenong South, Victoria 3164
Australia

Upon processing the transfer of warranty, Mercury Marine will send registration verification to the new owner of the product by mail. There is no charge for this service.

You may change your address at any time, including at the time of the warranty claim, by calling Mercury Marine or sending a letter or fax with your name, old address, new address, and hull identification number (HIN) to Mercury Marine's Warranty Registration Department.

GENERAL INFORMATION

Boater's Responsibilities

The operator (driver) is responsible for the correct and safe operation of the boat and the safety of its occupants and general public. It is strongly recommended that each operator read and understand this entire manual before operating the outboard.

Be sure that at least one additional person onboard is instructed in the basics of starting and operating the outboard and boat handling in case the driver is unable to operate the boat.

Before Operating Your Outboard

Read this manual carefully. Learn how to operate your outboard properly. If you have any questions, contact your dealer.

This manual as well as safety labels posted on the outboard use the following safety alerts to draw your attention to special safety instructions that should be followed.

WARNING

Indicates a hazardous situation which, if not avoided, could result in death or serious injury.

CAUTION

Indicates a hazardous situation which, if not avoided, could result in minor or moderate injury.

Boat Horsepower Capacity

WARNING

Exceeding the boat's maximum horsepower rating can cause serious injury or death. Overpowering the boat can affect boat control and flotation characteristics or break the transom. Do not install an engine that exceeds the boat's maximum power rating.

GENERAL INFORMATION

Do not overpower or overload your boat. Most boats will carry a required capacity plate indicating the maximum acceptable power and load as determined by the manufacturer following certain federal guidelines. If in doubt, contact your dealer or the boat manufacturer.

U.S. COAST GUARD CAPACITY	
MAXIMUM HORSEPOWER	XXX
MAXIMUM PERSON CAPACITY (POUNDS)	XXX
MAXIMUM WEIGHT CAPACITY	XXX

26777

High-Speed and High-Performance Boat Operation

If your outboard is to be used on a high-speed or high-performance boat with which you are unfamiliar, we recommend that you never operate it at its high speed capability without first requesting an initial orientation and familiarization demonstration ride with your dealer or an operator experienced with your boat/outboard combination. For additional information, obtain a copy of our **Hi-Performance Boat Operation** booklet from your dealer, distributor, or Mercury Marine.

Outboard Remote Control Models

The remote control connected to your outboard must be equipped with a start in neutral only protection device. This prevents the engine from starting when the shift is actuated in any position other than neutral.

GENERAL INFORMATION

⚠ WARNING

Starting the engine with the drive in gear can cause serious injury or death. Never operate a boat that does not have a neutral-safety-protection device.

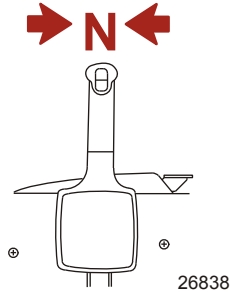

Remote Steering Notice

The steering link rod that connects the steering cable to the engine must be fastened utilizing self-locking nuts. These self-locking nuts must never be replaced with common nuts (nonlocking) as they will work loose and vibrate off, freeing the link rod to disengage.

⚠ WARNING

Improper fasteners or improper installation procedures can result in loosening or disengagement of the steering link rod. This can cause a sudden, unexpected loss of boat control, resulting in serious injury or death due to occupants being thrown within or out of the boat. Always use required components and follow instructions and torque procedures.

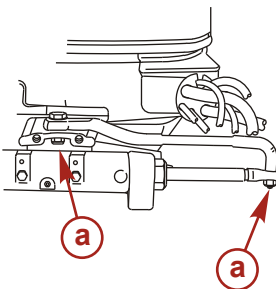

a - Self-locking nuts

GENERAL INFORMATION

Lanyard Stop Switch

The purpose of a lanyard stop switch is to turn off the engine when the operator moves far enough away from the operator's position (as in accidental ejection from the operator's position) to activate the switch. A lanyard stop switch can be installed as an accessory - generally on the dashboard or side adjacent to the operator's position.

While activation of the lanyard stop switch will stop the engine immediately, a boat will continue to coast for some distance depending upon the velocity and degree of any turn at shut down. However, the boat will not complete a full circle. While the boat is coasting, it can cause injury to anyone in the boat's path as seriously as the boat would when under power.

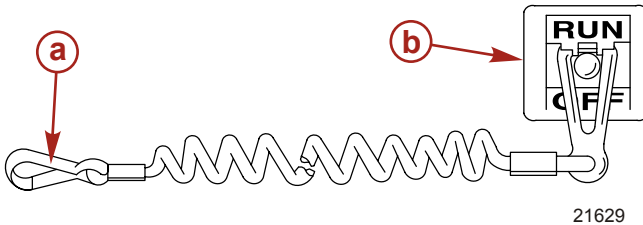

21629

- a** - Lanyard cord
- b** - Lanyard stop switch

We strongly recommend that other occupants be instructed on proper starting and operating procedures should they be required to operate the engine in an emergency (e.g. if the operator is accidentally ejected).

⚠ WARNING

If the operator falls out of the boat, stop the engine immediately to reduce the possibility of serious injury or death from being struck by the boat. Always properly connect the operator to the stop switch using a lanyard.

GENERAL INFORMATION

WARNING

Avoid serious injury or death from deceleration forces resulting from accidental or unintended stop switch activation. The boat operator should never leave the operator's station without first disconnecting the stop switch lanyard from the operator.

Accidental or unintended activation of the switch during normal operation is also a possibility. This could cause any, or all, of the following potentially hazardous situations:

- Occupants could be thrown forward due to unexpected loss of forward motion - a particular concern for passengers in the front of the boat who could be ejected over the bow and possibly struck by the gearcase or propeller.
- Loss of power and directional control in heavy seas, strong current, or high winds.
- Loss of control when docking.

Protecting People in the Water

WHILE YOU ARE CRUISING

It is very difficult for a person in the water to take quick action to avoid a boat heading in their direction, even at slow speeds.



21604

Always slow down and exercise extreme caution any time you are boating in an area where there might be people in the water. Whenever a boat is moving (even coasting) and the gear shift is in neutral, there is sufficient force by the water on the propeller to cause the propeller to rotate. This neutral propeller rotation can cause serious injury.

GENERAL INFORMATION

WHILE BOAT IS STATIONARY

WARNING

A spinning propeller, a moving boat, or any solid device attached to the boat can cause serious injury or death to swimmers. Stop the engine immediately whenever anyone in the water is near your boat.

Shift into neutral and shut off the engine before allowing people to swim or be in the water near your boat.

Exhaust Emissions

BE ALERT TO CARBON MONOXIDE POISONING

Carbon monoxide (CO) is a deadly gas that is present in the exhaust fumes of all internal combustion engines, including the engines that propel boats, and the generators that power boat accessories. By itself, CO is odorless, colorless, and tasteless, but if you can smell or taste engine exhaust, you are inhaling CO.

Early symptoms of carbon monoxide poisoning, which are similar to the symptoms of seasickness and intoxication, include headache, dizziness, drowsiness, and nausea.

WARNING

Inhaling engine exhaust gases can result in carbon monoxide poisoning, which can lead to unconsciousness, brain damage, or death. Avoid exposure to carbon monoxide.

Stay clear from exhaust areas when engine is running. Keep the boat well-ventilated while at rest or underway.

GENERAL INFORMATION

STAY CLEAR OF EXHAUST AREAS

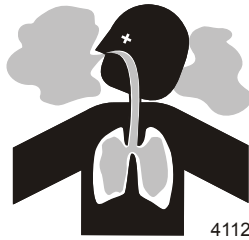

Engine exhaust gases contain harmful carbon monoxide. Avoid areas of concentrated engine exhaust gases. When engines are running, keep swimmers away from the boat, and do not sit, lie, or stand on swim platforms or boarding ladders. While underway, do not allow passengers to be positioned immediately behind the boat (platform dragging, teak/body surfing). This dangerous practice not only places a person in an area of high engine exhaust concentration, but also subjects them to the possibility of injury from the boat propeller.

GOOD VENTILATION

Ventilate the passenger area, open side curtains or forward hatches to remove fumes.

Example of desired air flow through the boat:

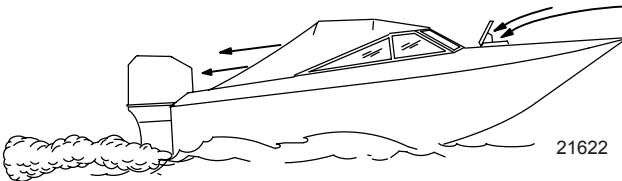

POOR VENTILATION

Under certain running and/or wind conditions, permanently enclosed or canvas enclosed cabins or cockpits with insufficient ventilation may draw in carbon monoxide. Install one or more carbon monoxide detectors in your boat.

GENERAL INFORMATION

Although the occurrence is rare, on a very calm day, swimmers and passengers in an open area of a stationary boat that contains, or is near, a running engine may be exposed to a hazardous level of carbon monoxide.

1. Examples of poor ventilation while the boat is stationary:

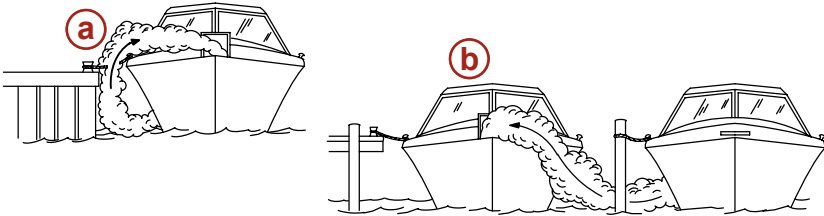

21626

- a** - Operating the engine when the boat is moored in a confined space
- b** - Mooring close to another boat that has its engine operating

2. Examples of poor ventilation while the boat is moving:

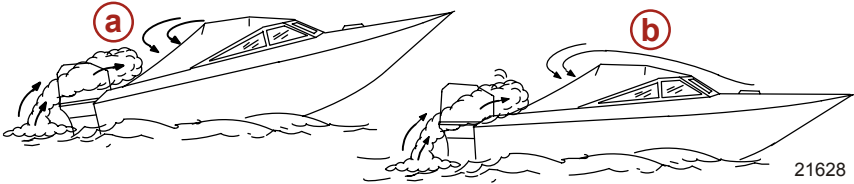

21628

- a** - Operating the boat with the trim angle of the bow too high
- b** - Operating the boat with no forward hatches open (station wagon effect)

GENERAL INFORMATION

Passenger Safety Message - Pontoon Boats and Deck Boats

Whenever the boat is in motion, observe the location of all passengers. Do not allow any passengers to stand or use seats other than those designated for traveling faster than idle speed. A sudden reduction in boat speed, such as plunging into a large wave or wake, a sudden throttle reduction, or a sharp change of boat direction, could throw them over the front of the boat. Falling over the front of the boat between the two pontoons will position them to be run over by the outboard.

BOATS HAVING AN OPEN FRONT DECK

No one should ever be on the deck in front of the fence while the boat is in motion. Keep all passengers behind the front fence or enclosure.

Persons on the front deck could easily be thrown overboard or persons dangling their feet over the front edge could get their legs caught by a wave and pulled into the water.

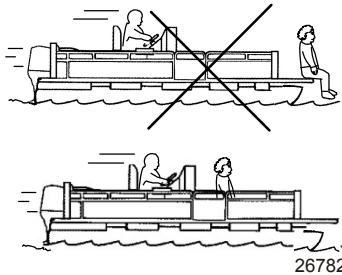

WARNING

Sitting or standing in an area of the boat not designed for passengers at speeds above idle can cause serious injury or death. Stay back from the front end of deck boats or raised platforms and remain seated while the boat is in motion.

GENERAL INFORMATION

BOATS WITH FRONT MOUNTED, RAISED PEDESTAL FISHING SEATS

Elevated fishing seats are not intended for use when the boat is traveling faster than idle or trolling speed. Sit only in seats designated for traveling at faster speeds.

Any unexpected, sudden reduction in boat speed could result in the elevated passenger falling over the front of the boat.

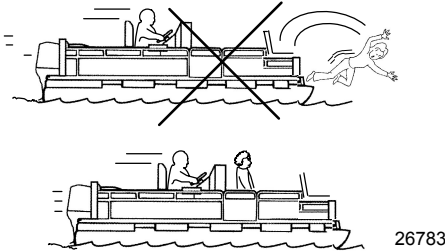

Wave and Wake Jumping

Operating recreational boats over waves and wake is a natural part of boating. However, when this activity is done with sufficient speed to force the boat hull partially or completely out of the water, certain hazards arise, particularly when the boat enters the water.

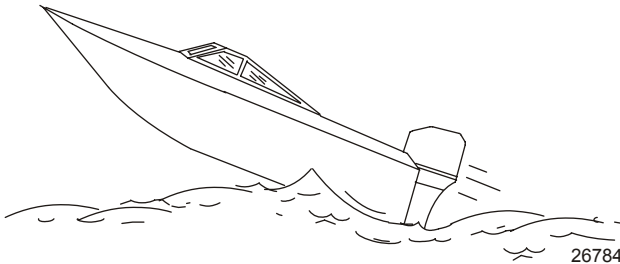

The primary concern is the boat changing direction while in the midst of the jump. In such case, the landing may cause the boat to veer violently in a new direction. Such a sharp change in direction can cause occupants to be thrown out of their seats, or out of the boat.

GENERAL INFORMATION

⚠ WARNING

Wave or wake jumping can cause serious injury or death from occupants being thrown within or out of the boat. Avoid wave or wake jumping whenever possible.

There is another less common hazardous result from allowing your boat to launch off a wave or wake. If the bow of your boat pitches down far enough while airborne, upon water contact it may penetrate under the water surface and submarine for an instant. This will bring the boat to a nearly instantaneous stop and can send the occupants flying forward. The boat may also steer sharply to one side.

Impact with Underwater Hazards

Reduce speed and proceed with caution whenever you drive a boat in shallow water areas, or in areas where you suspect underwater obstacles may exist which could be struck by the outboard or the boat bottom. **The most important thing you can do to help reduce injury or impact damage from striking a floating or underwater object is to control the boat speed. Under these conditions, boat speed should be kept to a minimum planing speed of 24 to 40 km/h (15 to 25 mph).**

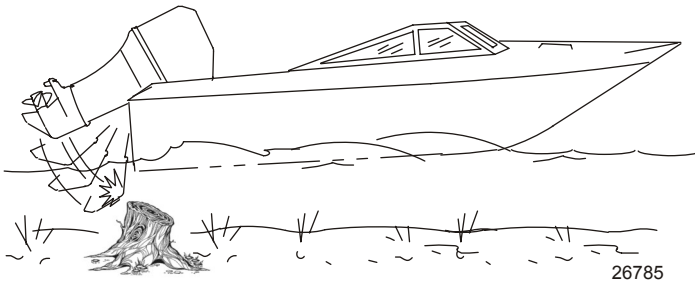

Striking a floating or underwater object could result in an infinite number of situations. Some of these situations could result in the following:

- Part of the outboard or the entire outboard could break loose and fly into the boat.

GENERAL INFORMATION

- The boat could move suddenly in a new direction. Such a sharp change in direction can cause occupants to be thrown out of their seats or out of the boat.
- A rapid reduction in speed. This will cause occupants to be thrown forward, or even out of the boat.
- Impact damage to the outboard and/or boat.

Keep in mind, the most important thing you can do to help reduce injury or impact damage during an impact is control the boat speed. Boat speed should be kept to a minimum planing speed when driving in waters known to have underwater obstacles.

After striking a submerged object, stop the engine as soon as possible and inspect it for any broken or loose parts. If damage is present or suspected, the outboard should be taken to an authorized dealer for a thorough inspection and necessary repair.

The boat should also be checked for any hull fractures, transom fractures, or water leaks.

Operating a damaged outboard could cause additional damage to other parts of the outboard, or could affect control of the boat. If continued running is necessary, do so at greatly reduced speeds.

WARNING

Operating a boat or engine with impact damage can result in product damage, serious injury, or death. If the vessel experiences any form of impact, have an authorized Mercury Marine dealer inspect and repair the vessel or power package.

Selecting Accessories for Your Outboard

Genuine Mercury Precision or Quicksilver Accessories have been specifically designed and tested for your outboard. These accessories are available from Mercury Marine dealers.

IMPORTANT: Check with your dealer before installing accessories. The misuse of approved accessories or the use of nonapproved accessories can damage the product.

GENERAL INFORMATION

Some accessories not manufactured or sold by Mercury Marine are not designed to be safely used with your outboard or outboard operating system. Acquire and read the installation, operation and maintenance manuals for all your selected accessories.

Safe Boating Recommendations

To safely enjoy the waterways, familiarize yourself with local and all other governmental boating regulations and restrictions and consider the following suggestions.

Know and obey all nautical rules and laws of the waterways.

- We recommend that all powerboat operators complete a boating safety course. In the U.S., the U.S. Coast Guard Auxiliary, the Power Squadron, the Red Cross, and your state or provincial boating law enforcement agency provide courses. For more information in the U.S., call the Boat U.S. Foundation at 1-800-336-BOAT (2628).

Perform safety checks and required maintenance.

- Follow a regular schedule and ensure that all repairs are properly made.

Check safety equipment onboard.

- Here are some suggestions of the types of safety equipment to carry when boating:
 - Approved fire extinguishers
 - Signal devices: flashlight, rockets or flares, flag, and whistle or horn
 - Tools necessary for minor repairs
 - Anchor and extra anchor line
 - Manual bilge pump and extra drain plugs
 - Drinking water
 - Radio
 - Paddle or oar
 - Spare propeller, thrust hubs, and an appropriate wrench
 - First aid kit and instructions

GENERAL INFORMATION

- Waterproof storage containers
- Spare operating equipment, batteries, bulbs, and fuses
- Compass and map or chart of the area
- Personal flotation device (one per person onboard)

Watch for signs of weather change and avoid foul weather and rough-sea boating.

Tell someone where you are going and when you expect to return.

Passenger boarding.

- Stop the engine whenever passengers are boarding, unloading, or are near the back (stern) of the boat. Shifting the drive unit into neutral is not sufficient.

Use personal flotation devices.

- Federal law requires that there be a U.S. Coast Guard-approved life jacket (personal flotation device), correctly sized and readily accessible for every person onboard, plus a throwable cushion or ring. We strongly advise that everyone wear a life jacket at all times while in the boat.

Prepare other boat operators.

- Instruct at least one person onboard in the basics of starting and operating the engine and boat handling in case the driver becomes disabled or falls overboard.

Do not overload your boat.

- Most boats are rated and certified for maximum load (weight) capacities (refer to your boat capacity plate). Know your boat's operating and loading limitations. Know if your boat will float if it is full of water. When in doubt, contact your authorized Mercury Marine dealer or the boat manufacturer.

Ensure that everyone in the boat is properly seated.

GENERAL INFORMATION

- Do not allow anyone to sit or ride on any part of the boat that was not intended for such use. This includes the backs of seats, gunwales, transom, bow, decks, raised fishing seats, and any rotating fishing seat. Passengers should not sit or ride anywhere that sudden unexpected acceleration, sudden stopping, unexpected loss of boat control, or sudden boat movement could cause a person to be thrown overboard or into the boat. Ensure that all passengers have a proper seat and are in it before any boat movement.

Never operate a boat while under the influence of alcohol or drugs. It is the law.

- Alcohol or drugs can impair your judgment and greatly reduce your ability to react quickly.

Know your boating area and avoid hazardous locations.

Be alert.

- The operator of the boat is responsible by law to maintain a proper lookout by sight and hearing. The operator must have an unobstructed view particularly to the front. No passengers, load, or fishing seats should block the operator's view when the boat is above idle or planing transition speed. Watch out for others, the water, and your wake.

Never drive your boat directly behind a water skier.

- Your boat traveling at 40 km/h (25 mph) will overtake a fallen skier who is 61 m (200 ft) in front of you in five seconds.

Watch fallen skiers.

- When using your boat for waterskiing or similar activities, always keep a fallen or down skier on the operator's side of the boat while returning to attend to the skier. The operator should always have the down skier in sight and never back up to the skier or anyone in the water.

Report accidents.

GENERAL INFORMATION

- Boat operators are required by law to file a boating accident report with their state boating law enforcement agency when their boat is involved in certain boating accidents. A boating accident must be reported if 1) there is loss of life or probable loss of life, 2) there is personal injury requiring medical treatment beyond first aid, 3) there is damage to boats or other property where the damage value exceeds \$500.00, or 4) there is complete loss of the boat. Seek further assistance from local law enforcement.

Recording Serial Number

It is important to record this number for future reference. The serial number is located on the outboard as shown.

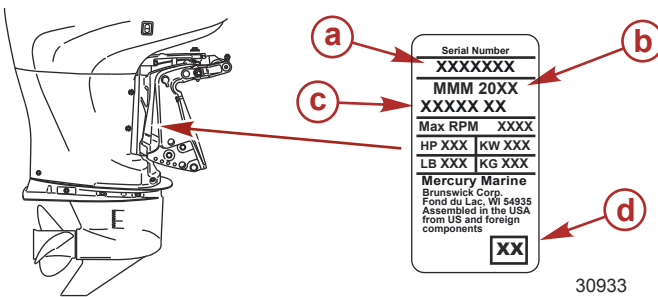

- a** - Serial number
- b** - Month and year of manufacture
- c** - Model designation
- d** - Year manufactured

GENERAL INFORMATION

Component Identification

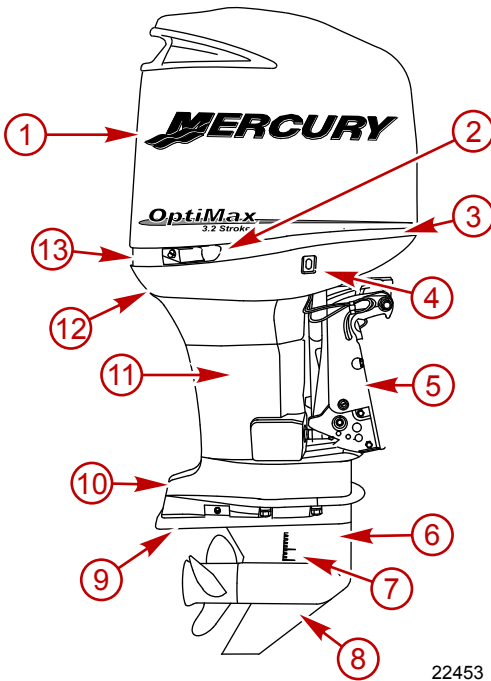

22453

- 1 - Top cowl
- 2 - Side cowl latches (both sides)
- 3 - Front cowl latch
- 4 - Auxiliary tilt switch
- 5 - Clamp/Swivel bracket
- 6 - Gearcase
- 7 - Cooling water intake (location dependent on gearcase)
- 8 - Skeg
- 9 - Anode plate
- 10 - Anti-ventilation plate
- 11 - Drive shaft housing
- 12 - Water pump indicator
- 13 - Bottom cowl

General Specifications OptiMax JP

GENERAL INFORMATION

Specifications		
Model		OptiMax JP
Cylinder configuration		60 Degree V6
Propshaft horsepower		180
Propshaft kilowatts		134
Engine weight	25 in. models	240 kg (528 lb)
	30 in. models	247 kg (544 lb)

GENERAL INFORMATION

Specifications	
Number of cylinders	6
Idle RPM	600 RPM
Full throttle RPM range	5500 – 5800 RPM
Neutral rev limit	2650 RPM
Overspeed rev limit	5950 RPM
Engine displacement	3032 cc (185.0 cu. in.)
Cylinder bore	92.075 mm (3.6250 in.)
Stroke	76.2 mm (3.00 in.)
Spark plug	NGK IZFR6J
Spark plug gap	0.81 mm (0.032 in.)
Firing order	1-2-3-4-5-6
Maximum timing	Not adjustable; controlled by ECM
Idle timing	
Fuel pressure	6.55 ± 0.14 bar [655 ± 13.8 kPa] (95 ± 2 psi)
Air pressure	7.58 ± 0.14 bar [758 ± 13.8 kPa] (110 ± 2 psi)
Gear ratio (Fleet Master)	2:1
Required fuel	JP-5, JP-8, or Jet A
Required engine oil	Mercury Multi-Fuel Outboard Oil
Gearcase oil	High-Performance Gear Lube
Gearcase capacity	710 ml (24 fl oz)
Battery rating	1000 marine cranking amps 800 cold cranking amps 105 amp hours ¹ .
Charging system output	50 A maximum
Emission control system	Electronic engine control (EC)

1. Battery manufacturers may rate and test their batteries to different standards. Consult with the specific battery manufacturer for comparison ratings.

GENERAL INFORMATION

Propeller Selection

Select a propeller that allows the engine to operate in the upper half of the recommended full throttle rpm range with the boat normally loaded (refer to **General Information - Specifications**). This RPM range allows for better acceleration while maintaining maximum boat speed.

If full throttle operation is below the recommended range, the propeller must be changed to prevent loss of performance and possible engine damage. On the other hand, operating an engine above the recommended operating rpm range will cause higher than normal wear and/or damage. Generally, there is a 200-300 RPM change between propeller pitches.

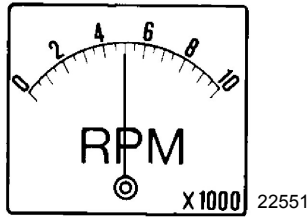

If changing conditions cause the rpm to drop below the recommended range (such as warmer, more humid weather, operation at higher elevations, increased boat load, or a dirty boat bottom/gearcase), a propeller change or cleaning may be required to maintain performance and ensure the outboards durability.

Check full-throttle RPM, using an accurate tachometer, with the engine trimmed out to a balanced-steering condition (steering effort equal in both directions) without causing the propeller to break loose.

TRANSPORTING

Trailing Boat/Outboard

Trailer your boat with the outboard tilted down in a vertical operating position.

If additional ground clearance is required, the outboard should be tilted up using an accessory outboard support device. Refer to your local dealer for recommendations. Additional clearance may be required for railroad crossings, driveways and trailer bouncing.

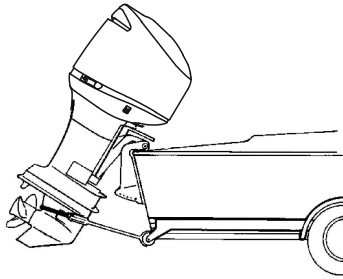

2722

IMPORTANT: Do not rely on the power trim/tilt system or tilt support lever to maintain proper ground clearance for trailering. The outboard tilt support lever is not intended to support the outboard for trailering.

Shift the outboard to forward gear. This prevents the propeller from spinning freely.

FUEL AND OIL

Fuel Requirements

NOTICE

The use of improper fuel can cause serious damage to the engine. Damage resulting from the use of improper fuel is considered engine misuse and is not covered under the limited warranty. Use only the recommended fuel in the engine.

Fuel Type	JP-5, JP-8, or Jet A
-----------	----------------------

Oil Requirement

Required Engine Oil	Mercury Multi-Fuel Outboard Oil 2.50 US gal (3.79 L) container (part number 92-858092A01) 55.00 US gal (208.2 L) container (part number 92-858093A01)
---------------------	--

Mercury Multi-Fuel Outboard Oil is a higher grade oil that provides increased lubrication and extra resistance to carbon buildup when used with good or varying grades of fuel.

IMPORTANT: Use only Mercury Multi-Fuel Outboard Oil in this engine. Using any other types of oil will void all warranties. Catastrophic failure will occur if any other oils are used.

Fuel Additives

To minimize carbon deposit buildup in the engine, it is recommended to add Mercury or Quicksilver Quikleen Engine Treatment additive to the engine's fuel at each tank fill throughout the boating season. Use additive as directed on container.

FUEL AND OIL

Avoiding Fuel Flow Restrictions

NOTICE

Adding components to the fuel supply system can damage the engine. These additions can restrict fuel flow, stall the engine at low speeds, and create lean fuel conditions at high speeds. Follow all regulations for fuel system installation and do not add any additional components to the fuel system.

Low Permeation Fuel Hose Requirement

Required for outboards manufactured for sale, sold, or offered for sale in the United States.

- The Environmental Protection Agency (EPA) requires that any outboard manufactured after January 1, 2009, must use low permeation fuel hose for the primary fuel hose connecting the fuel tank to the outboard.
- Low permeation hose is USCG Type B1-15 or Type A1-15, defined as not exceeding $15\text{gm}^2/24\text{ h}$ with CE 10 fuel at $23\text{ }^\circ\text{C}$ as specified in SAE J 1527 - marine fuel hose.

EPA Pressurized Portable Fuel Tank Requirements

The Environmental Protection Agency (EPA) requires portable fuel systems that are produced after January 1, 2011, for use with outboard engines to remain fully sealed (pressurized) up to 34.4 kPa (5.0 psi). These tanks may contain the following:

- An air inlet that opens to allow air to enter as the fuel is drawn out of the tank.
- An air outlet that opens (vents) to the atmosphere if pressure exceeds 34.4 kPa (5.0 psi).

Fuel Demand Valve (FDV) Requirement

Whenever a pressurized fuel tank is used, a fuel demand valve is required to be installed in the fuel hose between the fuel tank and primer bulb. The fuel demand valve prevents pressurized fuel from entering the engine and causing a fuel system overflow or possible fuel spillage.

FUEL AND OIL

The fuel demand valve has a manual release. The manual release can be used (pushed in) to open (bypass) the valve in case of a fuel blockage in the valve.

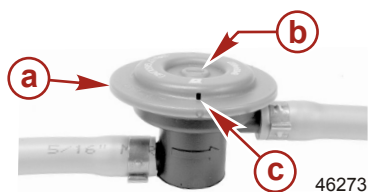

- a** - Fuel demand valve - installed in the fuel hose between the fuel tank and primer bulb
- b** - Manual release
- c** - Vent/water drain holes

Mercury Marine's Pressurized Portable Fuel Tank

Mercury Marine has created a new portable pressurized fuel tank that meets the preceding EPA requirements. These fuel tanks are available as an accessory or are provided with certain portable outboard models.

SPECIAL FEATURES OF THE PORTABLE FUEL TANK

- The fuel tank has a two-way valve which allows air to enter the tank as the fuel is drawn to the engine, and also opens to vent to the atmosphere if internal pressure in the tank exceeds 34.4 kPa (5.0 psi). A hissing noise may be heard as the tank vents to the atmosphere. This is normal.
- The fuel tank includes a fuel demand valve that prevents pressurized fuel from entering the engine and causing a fuel system overflow or possible fuel spillage.
- When installing the fuel tank cap, turn the cap to the right until you hear a click. This signals that the fuel cap is fully seated. A built-in device prevents overtightening.
- The fuel tank has a manual vent screw which should be closed for transportation and open for operation and cap removal.

Since sealed fuel tanks are not vented, they will expand and contract as the fuel expands and contracts during heating and cooling cycles of the outside air. This is normal.

FUEL AND OIL

REMOVING THE FUEL CAP

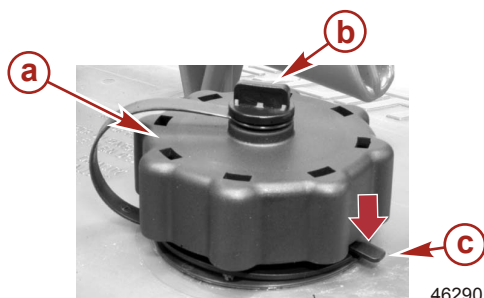

- a - Fuel cap
- b - Manual vent screw
- c - Tab lock

IMPORTANT: Contents may be under pressure. Rotate the fuel cap 1/4 turn to relieve pressure before opening.

1. Open the manual vent screw on top of the fuel cap.
2. Turn the fuel cap until it contacts the tab lock.
3. Press down on the tab lock. Rotate the fuel cap 1/4 turn to relieve the pressure.
4. Press down on the tab lock again and remove the cap.

DIRECTIONS FOR USING THE PRESSURIZED PORTABLE FUEL TANK

1. When installing the fuel tank cap, turn the cap to the right until you hear a click. This signals that the fuel cap is fully seated. A built-in device prevents overtightening.
2. Open the manual vent screw on top of the cap for operation and cap removal. Close the manual vent screw for transportation.
3. For fuel hoses that have quick disconnects, disconnect the fuel line from the engine or fuel tank when not in use.
4. Follow **Filling Fuel Tank** instructions for refueling.

Filling Remote Oil Tank

Remove filler cap and fill with the specified oil. Oil tank capacity is 11.5 liters (3 gallons). Replace filler cap and tighten securely.

FUEL AND OIL

IMPORTANT: Always make sure the oil tank caps are threaded on tight. An air leak will prevent oil flow to the engine.

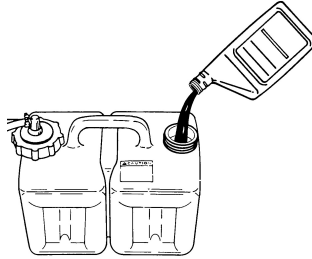

2723

Filling Engine Mounted Oil Reservoir Tank

Remove the top cowl. Loosen the fill cap on the engine oil reservoir tank. Run the engine until all the air has been vented out of the oil reservoir tank and tank is filled with oil to the point of overflow. Tighten the fill cap. Stop the engine and replace the top cowl.

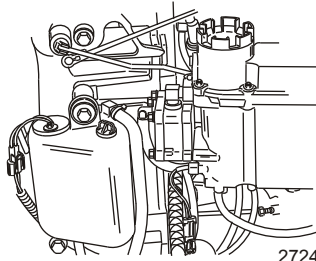

2724

NOTE: Filling this tank is only necessary if the oil level should ever drop and the low oil warning system is activated.

Filling Fuel Tank

- Fill fuel tanks outdoors away from heat, sparks, and open flames.
- Remove portable fuel tanks from boat to refill them.
- Always stop engine before refilling tanks.

FUEL AND OIL

- Do not completely fill the fuel tanks. Leave approximately 10% of the tank volume unfilled. Fuel will expand in volume as its temperature rises and can leak under pressure if the tank is completely filled.

WARNING

Avoid serious injury or death from a gasoline fire or explosion. Use caution when filling fuel tanks. Always stop the engine and do not smoke or allow open flames or sparks in the area while filling fuel tanks.

FEATURES AND CONTROLS

Remote Control Features

Your boat may be equipped with one of the Mercury Precision or Quicksilver remote controls shown. If not, consult your dealer for a description of the functions and operations of the remote control.

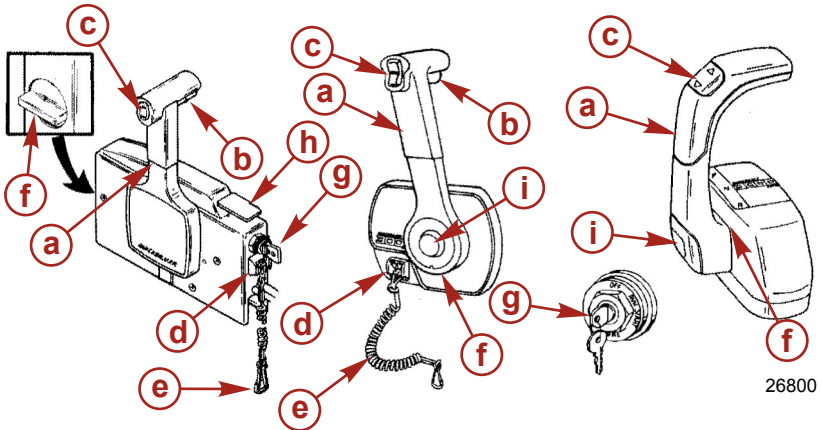

- a** - Control handle – forward, neutral, reverse
- b** - Neutral release lever
- c** - Trim/tilt switch (if equipped) – Refer to **Features and Controls – Power Trim and Tilt**
- d** - Lanyard stop switch – Refer to **General Information – Lanyard Stop Switch**
- e** - Lanyard – Refer to **General Information – Lanyard Stop Switch**
- f** - Throttle friction adjustment – Console controls require cover removal for adjustment
- g** - Ignition key switch – "OFF," "ON," "START"
- h** - Fast idle lever – Refer to **Operation – Starting the Engine**
- i** - Throttle only button – Refer to **Operation – Starting the Engine**

FEATURES AND CONTROLS

Zero Effort Control Features

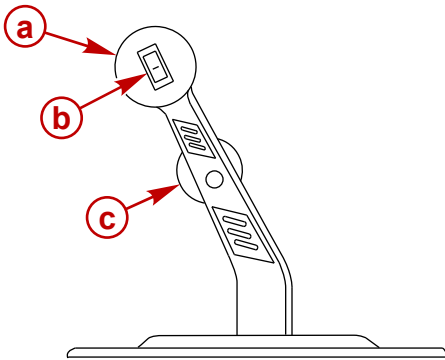

- a** - Throttle lever
- b** - Trim switch
- c** - Shift lever

4090

Warning System

WARNING HORN SIGNALS

When the key switch is turned to the "ON" position, the horn will turn on for a moment as a test to indicate the horn is working.

There are two types of warning horns to alert the operator of an active problem within the engine's operating system.

1. **Continuous six second beep:** Indicates a critical engine condition. Depending on the condition, the Engine Guardian system may engage and protect the engine by limiting its power. You should return to port immediately and contact your servicing dealer.
2. **Intermittent short beeps for six seconds:** Indicates a noncritical engine condition. This condition does not require immediate attention. You may continue using your boat, however, depending on the nature of the problem, the engine's power may be limited by the Engine Guardian system (see **Engine Guardian System** following) to protect the engine. You should contact your servicing dealer at your earliest convenience.

FEATURES AND CONTROLS

It is important to note that in either of the above scenarios, the horn will only sound one time. If you key the engine off and restart it, the horn will sound again, one time, if the fault is still present. For visual display of the specific engine functions and additional engine data, refer to **SmartCraft Product** information, following.

A few of the noncritical conditions indicated by the intermittent short beeps for six seconds can be corrected by the operator. These operator correctable conditions are as follows:

- Water in the engine mounted fuel filter. Refer to **Maintenance – Water Separating Fuel Filter**.
- Cooling system (water pressure or engine temperature) problem. Stop the engine and check the water intake holes in the lower unit for obstruction.
- Low engine oil level. Refer to **Fuel and Oil – Checking and Adding Engine Oil**.

ENGINE GUARDIAN SYSTEM

The Engine Guardian system monitors the critical sensors on the engine for any early indications of problems. Engine Guardian is functional whenever your engine is operating, so you never have to be concerned about whether or not you are protected. The system will respond to a problem by sounding the warning horn for six seconds and/or reducing engine power in order to provide engine protection.

If Engine Guardian has been activated, reduce the engine speed. The problem will need to be identified and corrected. The system must be reset before the engine will operate at higher speeds. Moving the throttle lever back to the idle position will reset the Engine Guardian system. If the Engine Guardian system has determined the reset has not corrected the problem, Engine Guardian will remain activated, limiting the throttle. The problem must be identified and corrected before Engine Guardian will allow the engine to reach a normal operating RPM.

FEATURES AND CONTROLS

OVERSPEED REV LIMIT

The overspeed rev limit is set at an RPM greater than the operating range. In the event that the engine is operated at an RPM greater than or equal to the overspeed limit, the PCM does not allow the engine to maintain the power requested by the operator. Refer to **Specifications** to determine this engine's RPM limit.

Upon reaching the beginning of the rev limit, Engine Guardian will cut-out the ignition to specific cylinders. If the operator does not reduce engine speed, Engine Guardian will cut-out the ignition to all the cylinders. There is no audible warning while Engine Guardian overspeed limit is active.

To reset the Engine Guardian protection:

1. Completely reduce the throttle for three seconds.
2. Engage the throttle. If the engine does not respond, repeat step one.

SMARTCRAFT PRODUCT

A Mercury SmartCraft System instrument package can be purchased for this outboard. A few of the functions the instrument package will display are engine RPM, coolant temperature, oil pressure, water pressure, battery voltage, fuel consumption, and engine operating hours.

The SmartCraft Instrument package will also aid in Engine Guardian diagnostics. The SmartCraft Instrument package will display critical engine alarm data and potential problems.

FEATURES AND CONTROLS

Power Trim and Tilt

NOTE: Outboard position can be adjusted by pressing trim switch. This range is used while operating your boat on plane.

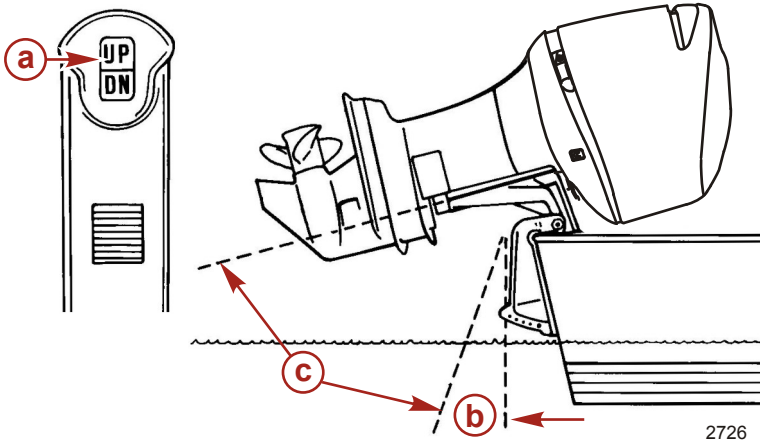

- a** - Trim switch
- b** - Trim range
- c** - Tilt range

- **Pressing (DN):** Moves the outboard in closer to the boat transom, called trimming in or down.
- **Pressing (UP):** Moves the outboard further away from the boat transom, called trimming out or up.
- **The term trim** generally refers to the adjustment of the outboard within the first 20° range of travel.
- **The term tilt** generally refers to adjusting the outboard further up out of the water.

With the engine turned off, the outboard can be tilted out of the water. At low idle speed, the outboard can also be tilted up past the trim range to permit, for example, shallow water operation.

FEATURES AND CONTROLS

POWER TRIM OPERATION

With most boats, operating around the middle of the trim range will give satisfactory results. Trimming your outboard all the way in or out may improve performance, but cause some potential control hazards.

WARNING

Trimming the outboard beyond a neutral steering condition may result in a pull on the steering wheel or tiller handle and loss of boat control. Maintain control of the boat if trimming beyond a neutral steering condition.

Consider the following lists carefully.

Trimming in or down can:

- Lower the bow of the boat.
- Result in quicker planing off.
- Generally improve the ride in choppy water.
- Increase steering torque or pull to the right (with the normal right-hand rotation propeller).
- In excess, lower the bow to a point at which the boat begins to plow with the bow in the water while on plane. This can result in an unexpected turn in either direction called bow steering or over steering if any turn is attempted, or if a significant wave is encountered.

LIMITING TRIM IN

In rare circumstances, the owner may decide to limit the trim in to avoid unsafe handling or steering conditions at planing speeds.

WARNING

Operating the boat at high speeds with the outboard trimmed too far under can create excessive bow steer, resulting in the operator losing control of the boat. Install the trim limit pin in a position that prevents excessive trim under and operate the boat in a safe manner.

FEATURES AND CONTROLS

WARNING

On some boats, increased trim-in range can cause handling problems at high speeds, resulting in personal injury or death. We recommend that only qualified personnel adjust the trim-in limit inserts and test the boat for handling problems.

IMPORTANT: Some boat/engine combinations not using a trim angle adjustment device, or trimmed to the full trim in position, may not exhibit any undesirable or unsafe handling or steering conditions. In these cases, a trim limiting device may not be advantageous to acceleration or planing. Always perform a water test to determine if these characteristics apply to a particular boat/engine combination.

To limit trim in on models with a three-ram trim system, purchase a stainless steel tilt pin from your dealer and insert it in whichever adjustment hole is desired.

To limit trim in on models with a single-ram trim system, use the cadmium plated bolt shipped with the engine.

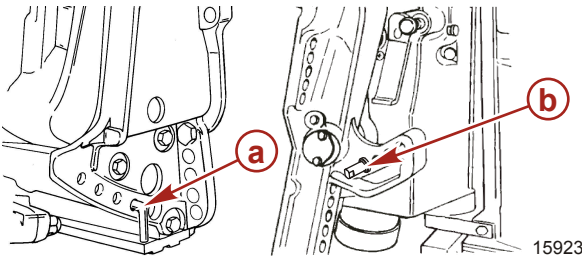

a - Stainless steel tilt pin (Three-Ram trim system)

b - Bolt shipped with engine (Single-Ram trim system)

Trimming out or up can:

- Lift the bow higher out of the water.
- Generally increase top speed.
- Gain clearance over submerged objects or a shallow bottom.

FEATURES AND CONTROLS

- Increase steering torque or pull to the left at a normal installation height (with the normal right hand rotation propeller).
- In excess, cause boat porpoising (bouncing) or propeller ventilation.
- Cause engine overheating if any cooling water intake holes are above the water line.

POWER TILT OPERATION (THREE-RAM TRIM SYSTEMS)

To tilt the outboard, shut off the engine and press the trim/tilt switch or the auxiliary tilt switch (located on the cowl) to the up position. The outboard tilts up until the switch is released or it reaches the maximum tilt position.

1. Engage the tilt support lever by pushing the metal stop and rotating the knob to bring the support lever upward.

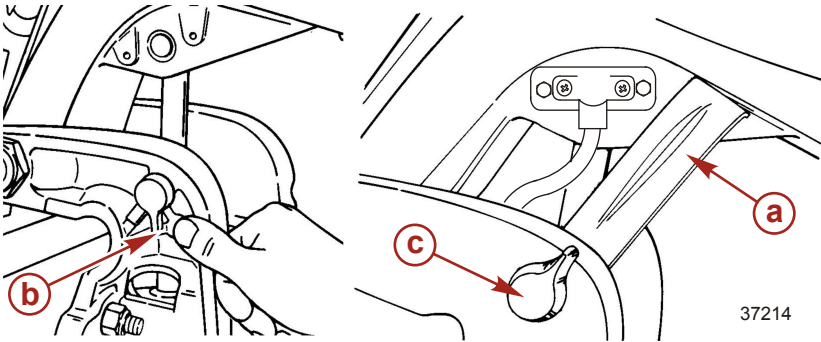

- a** - Tilt support lever
- b** - Metal stop
- c** - Knob

2. Lower the outboard to rest on the tilt support lever.
3. Disengage the tilt support lever by raising the outboard off the support lever and rotating the lever until it locks. Lower the outboard.

MANUAL TILT OPERATION

If the outboard cannot be tilted using the power trim/tilt switch, the outboard can be tilted manually.

FEATURES AND CONTROLS

1. Turn out the manual tilt release valve three turns (counterclockwise). This allows manual tilting of the outboard.

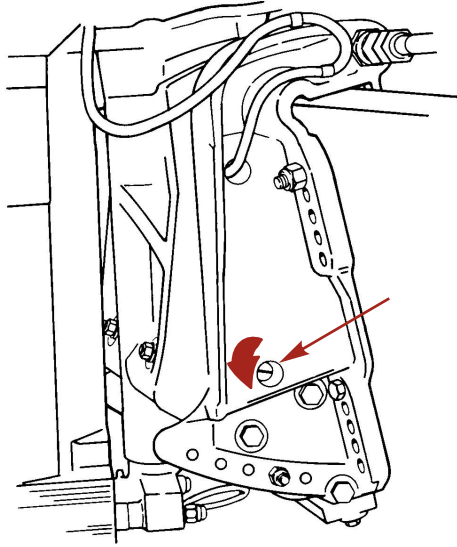

2728

2. Tilt the outboard to the desired position and tighten the manual tilt release valve.

NOTE: *The manual tilt release valve must be tightened before operating the outboard to prevent the outboard from tilting up during reverse operation.*

FEATURES AND CONTROLS

AUXILIARY TILT SWITCH

This switch can be used to tilt the outboard up or down using the power trim system.

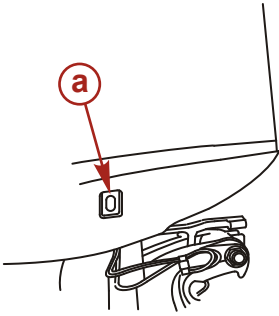

a - Auxiliary tilt switch

2745

OPERATION

Important Information

IMPORTANT DAILY INSPECTION BEFORE EACH USE

Any outboard mounted on the boat must have the mounting hardware inspected and checked to ensure that the hardware has not become loose. A decal on the transom bracket reminds the owner to check the fasteners securing the outboard to the transom before each use.

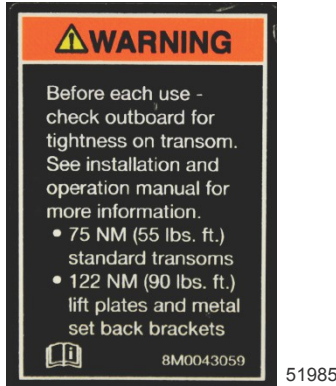

Decal on the transom bracket

BEFORE STARTING THE ENGINE

NOTICE

Lack of oil pressure in the system can cause severe internal engine damage during start-up. Prime the oil injection pump on new or rebuilt engines or after performing maintenance on the oiling system.

Refer to **Priming the Oil Injection Pump** for instructions.

FUEL REQUIREMENTS

Do not use premixed gas and oil in this engine. The engine automatically receives extra oil during engine break-in. Use a fresh supply of the recommended gasoline during engine break-in and after engine break-in.

OPERATION

OIL REQUIREMENT

Required Engine Oil	Mercury Multi-Fuel Outboard Oil 2.50 US gal (3.79 L) container (part number 92-858092A01) 55.00 US gal (208.2 L) container (part number 92-858093A01)
----------------------------	--

Mercury Multi-Fuel Outboard Oil is a higher grade oil that provides increased lubrication and extra resistance to carbon buildup when used with good or varying grades of fuel.

IMPORTANT: Use only Mercury Multi-Fuel Outboard Oil in this engine. Using any other types of oil will void all warranties. Catastrophic failure will occur if any other oils are used.

Engine Break-in

IMPORTANT: Failure to follow the engine break-in procedures can result in poor performance throughout the life of the engine and can cause engine damage. Always follow break-in procedures.

Break-in Procedure
Vary throttle settings during break-in. Use the following suggestions.
First Hour
<ul style="list-style-type: none">• Allow the engine to warm-up for 30–60 seconds.• Do not idle for more than five minutes.• Run the engine the majority of the time between 4000–5400 RPM (approximately three-quarter throttle).• Short bursts of wide-open throttle for 10 seconds or less are acceptable.• Change the engine speed approximately every two minutes.• Avoid trimming the outboard out (up) beyond a vertical trim position during operation.• Avoid using a hydraulic jack plate to raise the engine during the break-in cycle.
Next Three Hours: Change the engine speed every 10 minutes.

OPERATION

Engine Break-in Fuel Mixture

The propulsion control module (PCM) controls oil and fuel mixture during engine break-in.

Prestarting Check List

- Engine lowered to run position with all water intake holes submerged
- Fuel tank vent cap open or fuel drain valve on
- Fuel supply OK
- Lanyard stop switch in "RUN" position and cord connected
- Remote control in neutral
- Top cowl latches secure
- Make inspection checks listed in the **Inspection and Maintenance Schedule**. Refer to **Maintenance** section.

Operating in Freezing Temperatures

When using your outboard or having your outboard moored in freezing or near freezing temperatures, keep the outboard tilted down at all times so the gearcase is submerged. This prevents the trapped water in the gearcase from freezing and causing possible damage to the water pump and other components.

If there is a chance of ice forming on the water, the outboard should be removed and drained completely of water. If ice should form at the water level inside the outboard driveshaft housing, it will block water flow to the engine causing possible damage.

Operating in Saltwater or Polluted Water

We recommend that you flush the internal water passages of your outboard with fresh water after each use in salt or polluted water. This will prevent a buildup of deposits from clogging the water passages. Refer to **Maintenance - Flushing the Cooling System**.

If you keep your boat moored in the water, always tilt the outboard so the gearcase is completely out of water (except in freezing temperatures) when not in use.

OPERATION

Wash the outboard exterior and flush out the exhaust outlet of the propeller and gearcase with fresh water after each use. Each month, spray Mercury Precision or Quicksilver Corrosion Guard on external metal surfaces. Do not spray on corrosion control anodes as this will reduce the effectiveness of the anodes.

Operating at High Elevations

Your engine automatically compensates for high elevation changes. A different pitch propeller may help reduce some normal performance loss resulting from reduced oxygen in the air. Consult your dealer.

Effects of Elevation and Weather on Performance

The following conditions lower engine performance and cannot be compensated by the engine fuel or electronic management systems:

- Above sea level elevations
- High temperature
- Low barometric pressure
- High humidity

These conditions above reduce air density to the engine, which in turn lowers the following:

- Boost pressure on supercharged engines
- Horsepower and torque throughout the RPM range
- Peak RPM
- Cranking compression

EXAMPLE: An engine running at an elevation of 8,000 feet will have over a 30% power loss while a loss of engine power on a hot and humid day could be as much as 14%. These losses apply to normally aspirated and supercharged engines.

Compensating for power robbing conditions:

- Switch to lower pitch propeller.
- Change gear ratio.

OPERATION

Some boat performance can be improved by dropping to a lower pitch propeller, but engine performance will still remain lower. In some cases, a gear ratio reduction may be more beneficial. To optimize engine performance, prop the engine to allow it to operate at or near the top end of the recommended maximum RPM range at wide-open throttle with a normal boat load.

Other advantages to propeller or gear ratio changes:

- Reduces the possibility of detonation
- Enhances overall reliability and durability of the engine

Setting Trim Angle While Running Engine at Idle Speed

Submerging the exhaust relief hole on the outboard can happen on some boats if you trim full in while running at idle speed, resulting in, exhaust restriction, rough idle, excessive smoke, and fouled spark plugs. If this condition exists, trim outboard up until exhaust relief hole is out of the water.

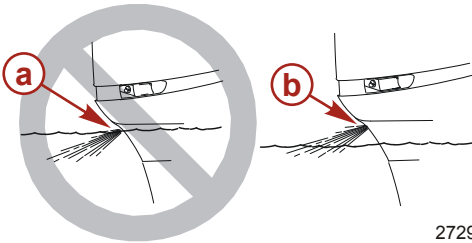

- a** - Relief hole submerged (wrong)
- b** - Relief hole above waterline (correct)

Operating in Shallow Water

When operating your boat in shallow water, you can tilt the outboard beyond the maximum trim range to prevent hitting bottom.

NOTICE

Operating the engine with the outboard in the tilt range can damage the engine or the transom. If operating the engine in the tilt range, such as in shallow water, do not exceed 2000 RPM.

1. Reduce engine speed below 2000 RPM.

OPERATION

2. Tilt outboard up. Make sure all the cooling water intake holes stay submerged at all times.
3. Operate the engine at slow speed only.

Models with a three-ram trim system: If engine speed exceeds 2000 RPM, the outboard will automatically return down to the maximum trim range.

Models with a single-ram trim system: The outboard will remain at the selected tilt position, regardless of engine RPM.

Starting The Engine

NOTICE

Without sufficient cooling water, the engine, the water pump, and other components will overheat and suffer damage. Provide a sufficient supply of water to the water inlets during operation.

INITIAL STARTING PROCEDURE

NOTE: For initial start up of a new engine, or for an engine that ran out of fuel or was drained of fuel, the fuel system should be filled according to the following procedure.

1. Squeeze the fuel line primer bulb until it feels firm.
2. Turn the ignition key switch to the "ON" position for three seconds. This operates the electric fuel pump.
3. Turn the ignition key switch back to the "OFF" position, and squeeze the primer bulb again until it feels firm. Turn the ignition key switch to the "ON" position again for three seconds. Continue this procedure until the fuel line primer bulb stays firm.

Before starting, read the **Pre-Starting Check List, Special Operating Instructions**, in the **Operation Section**.

OPERATION

STARTING PROCEDURE

1. Lower the outboard to the "RUN" position. Make sure all the cooling water intake holes are submerged.

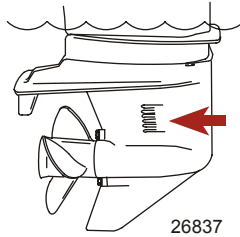

2. Open fuel tank filler cap vent screw (manual venting fuel tanks).

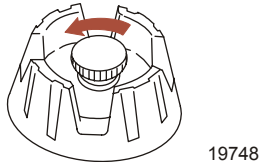

3. Squeeze the fuel line primer bulb several times until it feels firm.

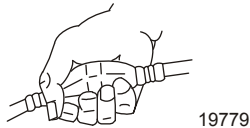

4. Set the lanyard stop switch to the "RUN" position. Read the Lanyard Stop Switch safety explanation and warning in the **General Information** section.

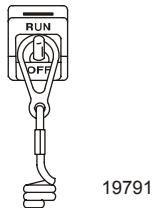

OPERATION

5. Shift the outboard to the neutral position.

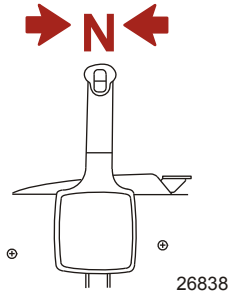

6. Do not advance the neutral fast idle speed feature on the remote control for starting (if equipped).

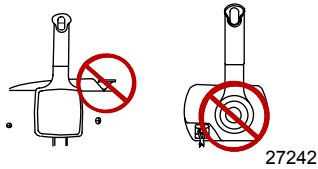

7. Turn the ignition key to the "START" position. Release the key when the engine starts. If the engine fails to start in ten seconds, return the key to the "OFF" position, wait one second, and try again.

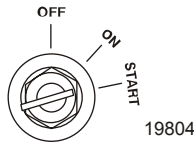

8. Check for water coming out of the water pump indicator hole.

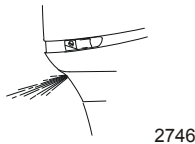

OPERATION

9. Allow the engine to warm up for at least 30 seconds before shifting out of neutral.

NOTE: *The electronic starting system will automatically prime (choke) the engine and increase idle speed for starting.*

NOTICE

Operating the engine while overheated can cause engine damage. If no water exits the water pump indicator hole, stop the engine and check the cooling water intake holes for obstruction. No obstruction may indicate a water pump failure or blockage in the cooling system, which can overheat the engine. Have an authorized Mercury Marine dealer check the system.

Gear Shifting

IMPORTANT: Never shift into gear unless the engine is at idle. Never shift into reverse without the engine running.

- Your outboard has three gear shift positions to provide operation: forward, neutral (out of gear) and reverse.

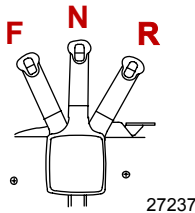

- When shifting, always stop at neutral position and allow the engine speed to return to idle.
- Always shift into gear with a quick motion.
- After shifting into gear, advance the lever further to increase speed.

OPERATION

Stopping the Engine

Reduce engine speed and shift outboard to neutral position. Turn ignition key to "OFF" position.

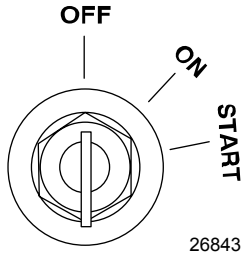

MAINTENANCE

Power Package Care

WARNING

Neglect or improper maintenance, repairs, or inspections of the power package can result in product damage or serious injury or death. Perform all procedures as described in this manual. If you are not familiar with proper maintenance or service procedures, consign the work to an authorized Mercury Marine dealer.

To ensure safety and retain dependability, keep your power package in the best operating condition by performing the periodic inspections and maintenance listed in the **Inspection and Maintenance Schedule**. Record maintenance performed in the **Maintenance Log** at the back of this book. Save all maintenance work orders and receipts.

Submerged Power Package

A submerged power package requires prompt service by an authorized dealer after recovery. This immediate attention is necessary once the engine is exposed to the atmosphere to minimize internal corrosion damage to the engine.

Replacement Parts for Your Power Package

Mercury recommends using original Mercury Precision replacement parts and lubricants.

MAINTENANCE

EPA Emissions Regulations

All new outboards manufactured by Mercury Marine are certified to the United States Environmental Protection Agency, as conforming to the requirements of the regulations for the control of air pollution from new outboard motors. This certification is contingent on certain adjustments set to factory standards. For this reason, the factory procedure for servicing the product must be strictly followed and, wherever practicable, returned to the original intent of the design. **Maintenance, replacement, or repair of the emission control devices and systems may be performed by any marine spark ignition (SI) engine repair establishment or individual.**

EMISSION CERTIFICATION LABEL

An emission certification label, showing emission levels and engine specifications directly related to emissions, is placed on the engine at time of manufacture.

The diagram shows a rectangular label with the Mercury logo on the left and the title "EMISSION CONTROL INFORMATION" on the right. The label contains several fields for engine specifications and emissions data. Red callouts labeled 'a' through 'i' point to specific fields: 'a' points to the Idle Speed field, 'b' to the hp field, 'c' to the cc field, 'd' to the Date of Manufacture field, 'e' to the Cold Valve Clearance field, 'f' to the Family Number field, 'g' to the FEL field, 'h' to the Timing field, and 'i' to the Spark Plug Gap field.

MERCURY		EMISSION CONTROL INFORMATION	
THIS ENGINE CONFORMS TO <input type="checkbox"/> CALIFORNIA AND U.S. EPA EMISSION REGULATIONS FOR SPARK IGNITION MARINE ENGINES			
REFER TO OWNERS MANUAL FOR REQUIRED MAINTENANCE, SPECIFICATIONS, AND ADJUSTMENTS			
IDLE SPEED (in gear): <input type="text"/>		FAMILY: <input type="text"/>	
<input type="text"/> hp	<input type="text"/> cc	FEL: <input type="text"/>	<input type="text"/> g/kWh
TIMING (IN DEGREES): <input type="text"/>			
<input type="text"/>	SPARK PLUG:		<input type="text"/>
	GAP:		<input type="text"/>
COLD VALVE CLEARANCE (mm): <input type="text"/>	INTAKE: <input type="text"/>	EXHAUST: <input type="text"/>	

- a - Idle speed
- b - Engine horsepower
- c - Piston displacement
- d - Date of manufacture
- e - Valve clearance (if applicable)
- f - Family number
- g - Maximum emission output for the engine family
- h - Timing specification
- i - Recommended spark plug and gap

MAINTENANCE

OWNER RESPONSIBILITY

The owner/operator is required to have routine engine maintenance performed to maintain emission levels within prescribed certification standards.

The owner/operator is not to modify the engine in any manner that would alter the horsepower or allow emissions levels to exceed their predetermined factory specifications.

Inspection And Maintenance Schedule

PRIOR TO EVERY USE

- Check that lanyard stop switch stops the engine.
- Check the oil and overheat audio warning system.
- Check the oil level in the reservoir.
- Visually inspect the fuel system for deterioration or leaks.
- Check the outboard for tightness on the transom.
- Check the steering system for binding or loose components.
- Visually check the steering link rod fasteners for proper tightness.
- Check the propeller blades for damage.
- Visually inspect all hoses, clamps, fittings, tubing, sealing gaskets, and mounting hardware for wear.

AFTER EACH SALTWATER OR POLLUTED WATER USE

- Flush all internal passages with fresh water.
- Wash the power package exterior (cowl, mid section, and gearcase) with fresh water.
- Flush the propeller and gearcase exhaust outlet with fresh water.
- Remove the cowl and wipe off any saltwater spray with a damp cloth.

AFTER THE FIRST 20 HOURS OF USE

- Check the water separating fuel filter for water or contaminants.
- Drain and replace the gearcase lubricant.
- Inspect the battery.

MAINTENANCE

- Check the control cable adjustments.
- Lubricate all lubrication points.
- Check the tightness of all bolts, nuts, and other fasteners.
- Remove the propeller. Clean and lubricate the propeller shaft with Extreme Grease or 2-4-C with PTFE.
- Tighten the propeller retaining nut to the correct torque specifications.
- Spray the powerhead and undercowl components with Corrosion Guard.

EVERY 50 HOURS OR ONCE A MONTH, WHICHEVER OCCURS FIRST

- Visually inspect the front and side cowl latches for tightness. Tighten if necessary.
- Visually inspect the fuel and oil systems for deterioration or leaks.
- Visually check steering link rod fasteners for wear. Lubricate all components (refer to the **Installation Manual** for lubrication specifications). Check all attachment hardware for proper torque tightness.
- Inspect the water separating fuel filter for water or contaminants. Replace if necessary
- Lubricate all lubrication points.
- Lubricate entire length of drive shaft with Extreme Grease.
- Lubricate splines on the propeller shaft.
- Check the level and condition of the gearcase lubricant.
- Inspect the battery.
- Check the corrosion control anodes. Replace if over 50% corroded.
- Check the tightness of all bolts, nut, and other fasteners.
- Lubricate the starter motor shaft with a light machine oil or silicone spray. Do not overlubricate.
- Spray the powerhead and all external, unpainted metal surfaces (except anodes) with Corrosion Guard.
- Inspect all belts, pulleys, and idler pulleys for deterioration.

MAINTENANCE

- Check fuel pressure.
- Remove engine deposits with Power Tune Engine Cleaner.

EVERY 100 HOURS OR ONCE A YEAR, WHICHEVER OCCURS FIRST

- Check the spark plug gap. Clean and replace plugs if necessary.
- Inspect spark plug leads for damage or deterioration. Replace if necessary.
- Drain and replace the gearcase lubricant.
- Check the power trim fluid.
- Check control cable adjustments.
- Replace the water pump impeller (more often if overheating occurs or reduced water pressure is noted).

EVERY 200 HOURS OR ONCE A YEAR, WHICHEVER OCCURS FIRST

- Replace spark plugs.

EVERY 300 HOURS OR ONCE A YEAR, WHICHEVER OCCURS FIRST

- Replace the water pump impeller (more often if overheating occurs or reduced water pressure is noted).
- Lubricate the driveshaft and shift shaft splines.
- Remove the bearing carrier nut (on the gearcase) and the bearing carrier. Lubricate the bearing carrier and gearcase cover nut with 2-4-C with PTFE. This procedure is recommended if the outboard is used in a saltwater environment. Refer to the **Service Manual** for instructions.
- Clean the entire unit, including accessible powerhead parts. Touch up any paint nicks. Clean and paint corroded areas. If corrosion is severe, try to isolate the cause of corrosion and correct.
- Check the entire outboard for loose, damaged, or missing parts. Tighten or replace as required.
- Inspect fuel lines for damage or deterioration and service fuel filters.

MAINTENANCE

- Inspect oil pump lines to make sure they have not become hard or brittle. Replace if necessary.
- Remove and inspect propeller(s). Trim propeller blade nicks and burrs with a file. Inspect for cracks or bent blades. Coat propeller shaft with Extreme Grease or 2-4-C with PTFE.
- Check corrosion control anodes. Replace if 50% corroded.
- Check remote controls and steering. Ensure that all connections and fittings are tight and properly secured and adjusted.
- Inspect carbon fiber reeds for chipping or cracks.

BEFORE PERIODS OF STORAGE

- Refer to the **Storage** section.

Flushing the Cooling System (Powerhead)

Flush the internal water passages of the engine with fresh water after each use in salt, polluted, or muddy water. This will help prevent a buildup of deposits from clogging the internal water passages.

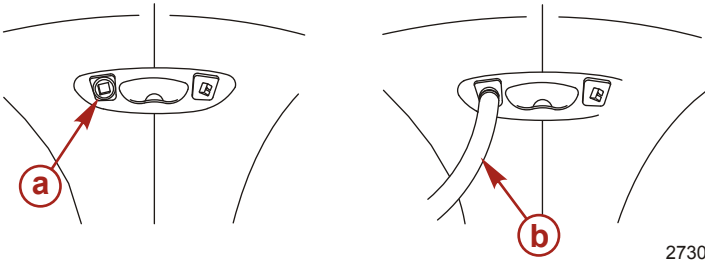

a - Plug located on fitting

b - Water hose

1. Remove the plug from fitting in the bottom cowl.
2. Attach a water hose to the fitting. Turn on the water and flush for three to five minutes.

NOTE: *The engine can be stopped or operated at idle speed when flushing the cooling system. Do not flush engine using a water system that exceeds 310 kPa (45 psi).*

MAINTENANCE

Flushing the Cooling System (Lower Unit)

⚠ WARNING

Rotating propellers can cause serious injury or death. Never operate the boat out of the water with a propeller installed. Before installing or removing a propeller, place the drive unit in neutral and engage the lanyard stop switch to prevent the engine from starting. Place a block of wood between the propeller blade and the anti-ventilation plate.

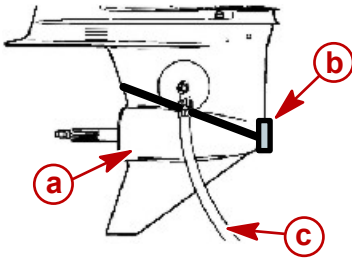

- a - Fleet Master Master gearcase
- b - Flushing attachments
- c - Water hose

or128

1. Remove the propeller. Refer to **Propeller Replacement**.
2. Install the appropriate flushing attachment so the rubber cups fit tightly over the strut intake holes. Attach the Dual Water Flush Seal over the nose inlets.
3. Attach a water hose to the flushing attachment. Turn on the water and adjust the flow so water is leaking around the rubber cups to ensure the engine receives an adequate supply of cooling water.
4. Start the engine and run it at idle speed in neutral shift position.
5. Adjust water flow so excess water continues leaking out from around the rubber cups to ensure the engine is receiving an adequate supply of cooling water.
6. Check for water coming out of the water pump indicator hole. Continue flushing for three to five minutes, carefully monitoring water supply at all times.
7. Stop the engine, turn off the water, and remove the flushing attachments. Re-install the propeller.

MAINTENANCE

Top Cowl Removal and Installation

REMOVAL

Release the front and side cowl latches. Lift the top cowl from the outboard.

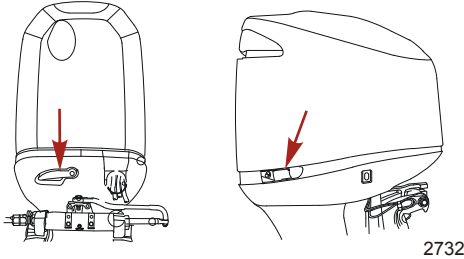

INSTALLATION

Position the top cowl over the engine. Make sure the bottom rubber seal fits properly and lock the front and side latches.

Cleaning Care for Top Cowl

IMPORTANT: Dry wiping (wiping the plastic surface when it is dry) will result in minor surface scratches. Always wet the surface before cleaning. Follow the cleaning and waxing procedure.

CLEANING AND WAXING PROCEDURE

1. Before washing, rinse the top cowl with clean water to remove the dirt and dust that may scratch the surface.
2. Wash the top cowl with clean water and a mild nonabrasive soap. Use a soft, clean cloth when washing.
3. Dry thoroughly with a soft, clean cloth.
4. Wax the surface using a nonabrasive automotive polish (polish designed for clear coat finishes). Remove the applied wax by hand using a soft, clean cloth.

MAINTENANCE

Fuel System

FUEL SYSTEM SERVICE INFORMATION

WARNING

Fuel is flammable and explosive. Ensure that the key switch is off and the lanyard is positioned so that the engine cannot start. Do not smoke or allow sources of spark or open flame in the area while servicing. Keep the work area well ventilated and avoid prolonged exposure to vapors. Always check for leaks before attempting to start the engine, and wipe up any spilled fuel immediately.

IMPORTANT: Use an approved container to collect and store fuel. Wipe up any spillage immediately. Material used to contain spillage must be disposed of in an approved receptacle.

Before servicing any part of the fuel system:

- Stop engine and disconnect the battery.
- Drain the fuel system completely.
- Perform fuel system service in a well-ventilated area.
- Inspect any completed service work for sign of fuel leakage.

FUEL LINE INSPECTION

Visually inspect the fuel line and primer bulb for cracks, swelling, leaks, hardness, or other signs of deterioration or damage. If any of these conditions are found, the fuel line or primer bulb must be replaced.

WATER SEPARATING FUEL FILTER

This filter removes moisture and debris from the fuel. If the filter becomes filled with water, the water can be removed. If the filter becomes plugged with debris, replace the filter. The warning system engages when water in the fuel filter reaches the full level. Refer to **Warning System** in **Features and Controls**.

Refer to the **Inspection and Maintenance Schedule** for the proper maintenance interval.

MAINTENANCE

Removal

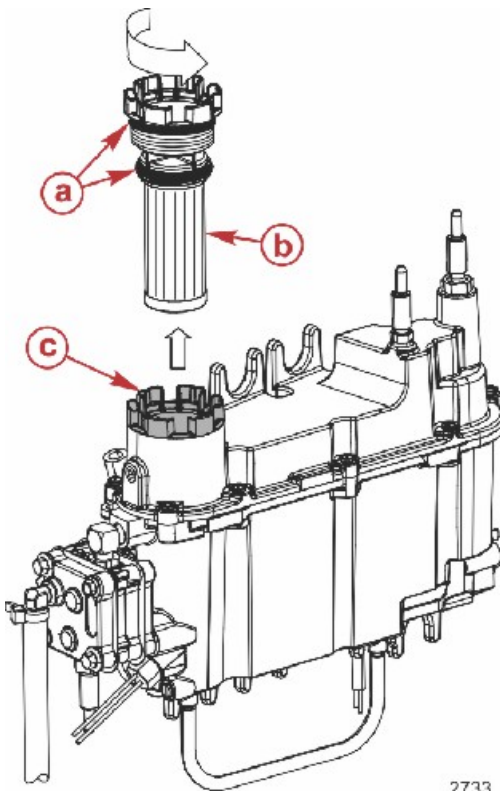

- a - O-ring seals
- b - Filter
- c - Raised bosses

2733

1. Disconnect the link rod.
2. Use the shaft of a screwdriver between the filter cap bosses and unscrew the filter.

Installation

1. Lubricate the O-ring seals with oil.
2. Install the fuel filter and tighten securely.
3. Connect the link rod.

IMPORTANT: Visually inspect for fuel leakage from the filter while squeezing the primer bulb until firm, forcing fuel into the filter.

MAINTENANCE

DRAINING WATER FROM THE FUEL FILTER CHAMBER

NOTE: If a sufficient amount of water accumulates in the fuel filter chamber, the engine's warning system alerts the operator with the warning horn. Some SmartCraft gauges are capable of alerting the operator of this and other operating conditions/faults. Refer to **Warning System** in the **Features and Controls** section of this manual for more information. If the warning system alerts you to this condition, drain the water from the fuel filter chamber.

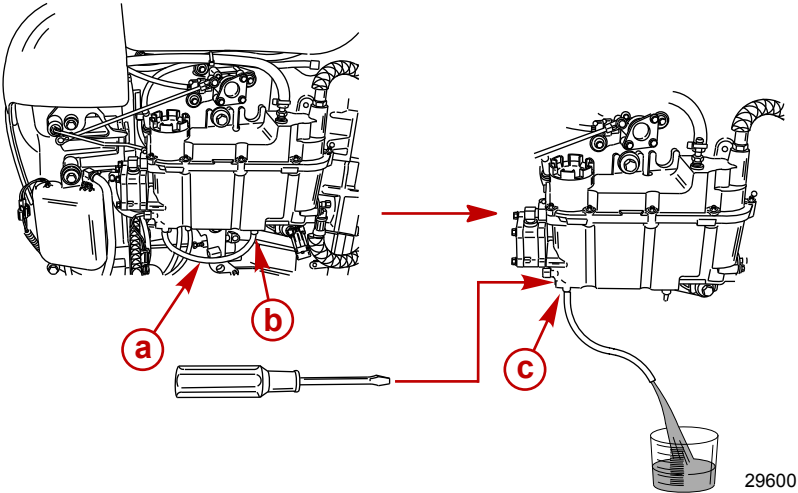

- a** - Drain hose
- b** - Aft hose fitting
- c** - Filter drain screw

1. Remove the drain hose from the aft hose fitting (right side of the chamber). Hold the unattached end of the hose over a suitable container.
2. Loosen the filter drain screw (left side of the chamber) and allow the contents to drain.

NOTE: If little or no liquid drains from the hose, loosen the red filter to vent the chamber.

3. Tighten the drain screw and attach the hose.

MAINTENANCE

IMPORTANT: Visually inspect for fuel leakage from the drain screw by squeezing the primer bulb until firm, forcing fuel into the chamber.

If you experience multiple issues with water in the fuel system over a short period of time, see your authorized Mercury dealer.

Steering Link Rod Fasteners

IMPORTANT: The steering link rod that connects the steering cable to the engine must be fastened using a special washer head bolt (P/N 10-849838) and self-locking nylon insert locknuts (P/N 11-826709113). Never replace locknuts with common nuts (nonlocking) as they will work loose and vibrate off, freeing the link rod to disengage.

WARNING

Improper fasteners or improper installation procedures can result in loosening or disengagement of the steering link rod. This can cause a sudden, unexpected loss of boat control, resulting in serious injury or death due to occupants being thrown within or out of the boat. Always use required components and follow instructions and torque procedures.

MAINTENANCE

⚠ WARNING

Worn, loose, or seized steering components can lead to loss of boat control. Inspect all steering attachment components for wear, lubricate all attachment hardware, and check all fasteners for proper tightness in accordance with the inspection and maintenance schedule.

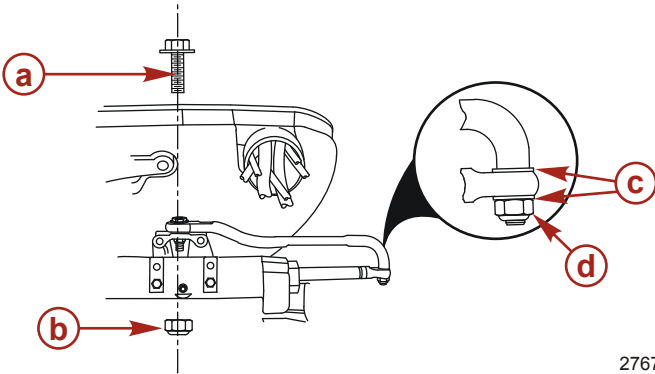

2767

- a** - Special washer head bolt (P/N 10-849838)
- b** - Nylon insert locknut (P/N 11-826709113) - used on head bolt
- c** - Flat washer (2)
- d** - Nylon insert locknut (P/N 11-826709113) - used on cable coupler

1. Assemble steering link rod to steering cable coupler with two flat washers "c" and a self-locking nylon insert locknut "d." Tighten the locknut until it seats, then loosen ¼ turn.
2. Assemble the steering link rod to the engine with the special washer head bolt "a" and self-locking nylon insert locknut "b."
3. Torque the head bolt, then the locknut to specifications.

Description	Nm	lb-in.	lb-ft
Cable coupler nylon insert locknut "d"	Tighten locknut until it seats, then loosen ¼ turn.		
Head bolt nylon insert locknut "b"	27	–	20

MAINTENANCE

Description	Nm	lb-in.	lb-ft
Special washer head bolt	27	–	20

Fuses

IMPORTANT: Always carry spare 2-, 15-, and 20-amp fuses.

The electrical wiring circuits on the engine are protected from overload by fuses in the wiring. If a fuse is blown, try to locate and correct the cause of the overload before replacing the fuse. If the cause is not found, the fuse may blow again.

1. Open the fuse holder and look at the silver colored band inside the fuse. If the band is broken, replace the fuse.
2. Replace fuse with a new fuse with the same rating.

MAINTENANCE

The fuses and circuits are identified as follows:

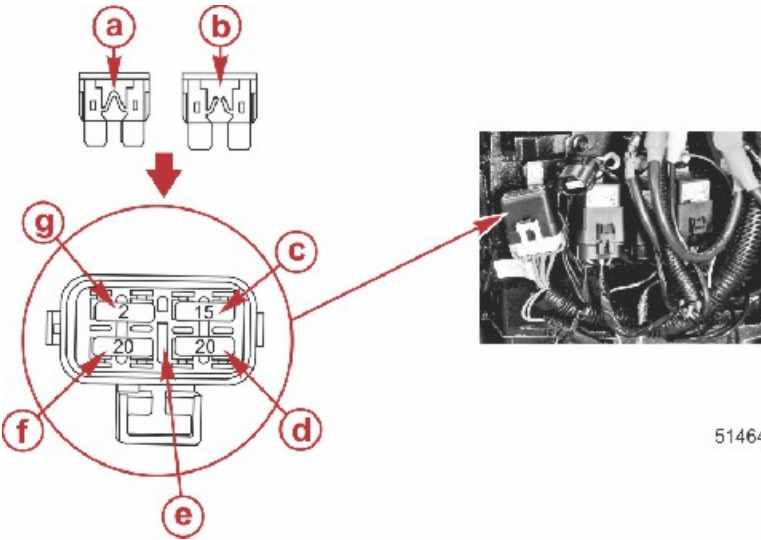

51464

Fuse location and identification

- a** - Good fuse
- b** - Blown fuse
- c** - Power-on circuit – 15-amp fuse
- d** - Ignition coil circuit – 20-amp fuse
- e** - Spare fuse slot
- f** - Fuel injector/direct injector/PCM and electric fuel pump circuits – 20-amp fuse
- g** - Diagnostic circuit – 2-amp fuse

Corrosion Control Anode

NOTICE

Anodes made of insufficiently pure aluminum alloys may not adequately protect critical drive components from corrosion. We recommend using anodes sold through Mercury Precision Parts only.

MAINTENANCE

Anodes help protect the power package against galvanic corrosion by sacrificing its metal to be slowly eroded instead of other metals.

This model has three corrosion control anodes—two above and one below the anti-ventilation plate. A fourth anode is located on the bottom of the clamp/swivel bracket assembly.

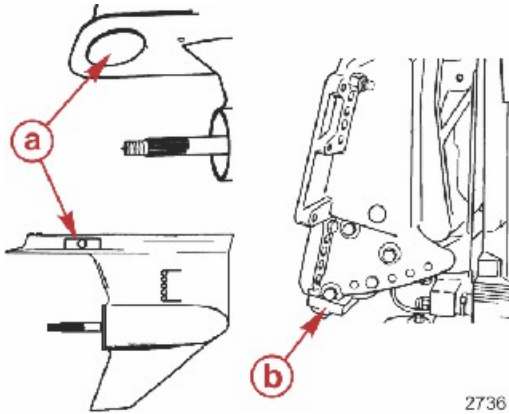

- a - Corrosion control anodes (three on gearcase)
- b - Corrosion control anode (one on clamp/swivel bracket)

All anodes require periodic inspection, especially in saltwater (refer to the **Inspection and Maintenance Schedule**). Replace any anodes before they are 50% corroded. Never paint or apply protective coating on the anode, as effectiveness of the anode will be reduced.

Spark Plug Inspection and Replacement

WARNING

Damaged spark plug boots may emit sparks that can ignite fuel vapors under the engine cowl, resulting in serious injury or death from a fire or explosion. To avoid damaging the spark plug boots, do not use any sharp object or metal tool to remove the spark plug boots.

MAINTENANCE

1. Remove the spark plug leads. Twist the rubber boots slightly and pull off.

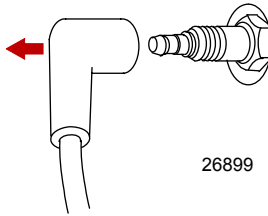

2. Remove the spark plugs to inspect. Replace spark plug if electrode is worn or the insulator is rough, cracked, broken, blistered or fouled.
3. Set the spark plug gap to specifications.

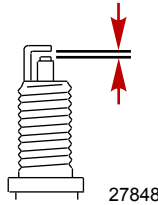

Spark Plug Gap	0.81 mm (0.032 in.)
-----------------------	---------------------

4. Before installing spark plugs, clean off any dirt on the spark plug seats. Install plugs finger tight, and then tighten 1/4 turn or torque to specifications.

Description	Nm	lb. in.	lb. ft.
Spark plug	27		20

Battery Inspection

The battery should be inspected at periodic intervals to ensure proper engine starting capability.

IMPORTANT: Read the safety and maintenance instructions which accompany your battery.

1. Turn off the engine before servicing the battery.
2. Ensure the battery is secure against movement.
3. Battery cable terminals should be clean, tight, and correctly installed. Positive to positive and negative to negative.

MAINTENANCE

4. Ensure the battery is equipped with a nonconductive shield to prevent accidental shorting of battery terminals.

Charging System Fusible Link

This model has a 100 ampere fusible link between the alternator and the +12 volt stud. This fusible link protects the alternator from damage due to accidental reverse battery connection. If the battery cables are reversed, the fusible link creates an open circuit, protecting the alternator. With the fusible link open, the engine can be started; however, the run time is limited, because the alternator is not charging the boat battery. If the fusible link circuit becomes open, contact your authorized Mercury Marine dealer.

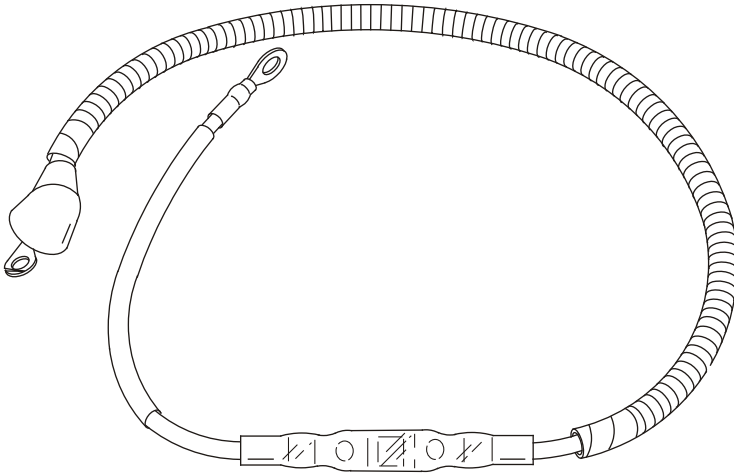

3797

Replacing the Propeller

WARNING

Rotating propellers can cause serious injury or death. Never operate the boat out of the water with a propeller installed. Before installing or removing a propeller, place the drive unit in neutral and engage the lanyard stop switch to prevent the engine from starting. Place a block of wood between the propeller blade and the anti-ventilation plate.

MAINTENANCE

REMOVING THE PROPELLER

NOTE: *If propeller is seized to the shaft and cannot be removed, consult your authorized Mercury dealer.*

1. Shift the outboard to neutral.
2. Remove the keys from the ignition and engage the safety stop switch.
3. Straighten the bent tabs on the propeller nut retainer (if applicable).
4. Place a block of wood between the gearcase and the propeller to hold the propeller and remove the propeller nut.

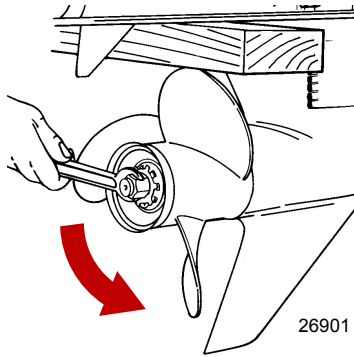

5. Remove the propeller and associated hardware from the propeller shaft.

INSTALLING THE PROPELLER

NOTICE

Operating the engine with the wrong propeller installed can limit power, increase fuel consumption, overheat the engine, or cause internal powerhead damage. Choose a propeller that allows the engine to operate at the specified wide open throttle RPM.

Mercury Racing applications use 19-spline propeller shafts and require installation of the Heavy-Duty Propeller Hub kit, included with most Mercury Racing propellers.

MAINTENANCE

IMPORTANT: To prevent the propeller hub from corroding and seizing to the propeller shaft, especially in salt water, always apply a coat of Extreme Grease to the entire propeller shaft at the recommended maintenance intervals and also each time the propeller is removed.

1. Lubricate the propeller shaft splines with Extreme Grease.
2. Install the propeller hub assembly, propeller, washer, Belleville washer, washer, and propeller nut onto the propeller shaft.

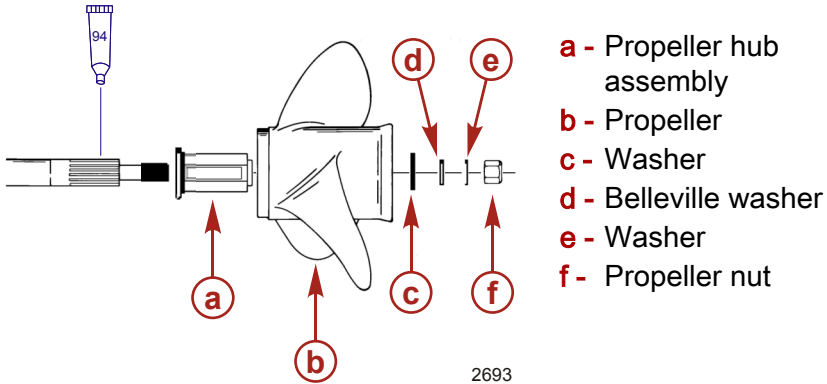

Tube Ref No.	Description	Where Used	Part No.
	Extreme Grease	Propeller shaft splines	8M0071842

3. Place a block of wood between the gearcase and propeller and torque the propeller nut.

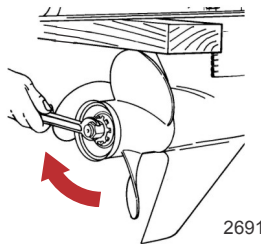

Description	Nm	lb. in.	lb. ft.
Propeller nut	75		55



MAINTENANCE

- Disengage the safety stop switch by placing it in the "RUN" position and return the keys to the ignition switch.

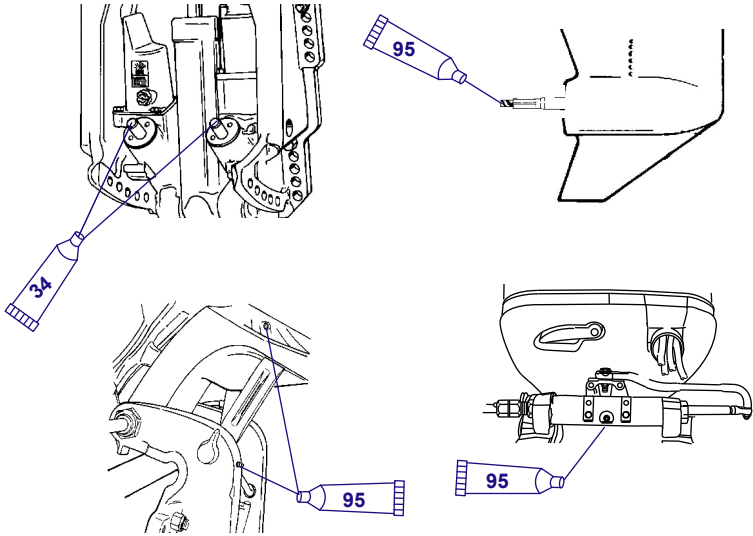
Lubrication Points



or45-1

Tube Ref. No.	Description	Where Used	Part Number
	Extreme Grease	Trim Rod Ball Ends	92-802865A1
	2-4-C with PTFE	Prop Shaft	92-802859A1
		Swivel Bracket	
		Tilt Support Lever	
		Tilt Tube	

NOTE: Turn the ball ends to work the lubricant into the ball sockets. Lubricate through fittings



MAINTENANCE

⚠ WARNING

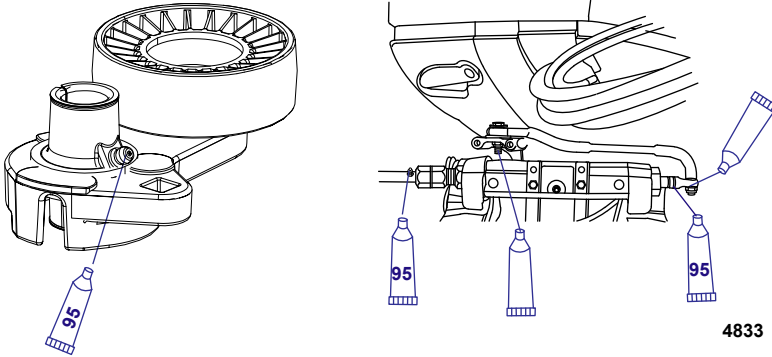
Incorrect cable lubrication can cause hydraulic lock, leading to serious injury or death from loss of boat control. Completely retract the end of the steering cable before applying lubricant.



4833

Tube Ref. No.	Description	Where Used	Part Number
	2-4-C with PTFE	Steering Cable and Grease Fitting on Belt Tensioner Pulley	92-802859A1
	Light weight oil	Steering Cable	Obtain Locally

MAINTENANCE

Checking Power Trim Fluid (Three-Ram Trim Systems)

1. Tilt outboard to the full up position and engage the tilt support lock.

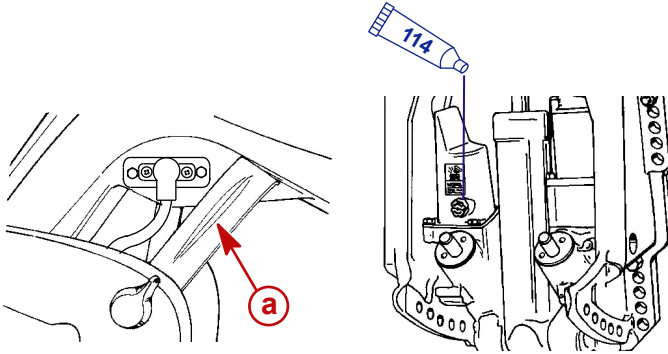

or47-1

a - Tilt support lock

Tube Ref. No.	Description	Where Used	Part Number
 114	Power Trim and Steering Fluid	Fill hole	92-802880A1

2. Remove fill cap and check fluid level. The fluid level should be even with the bottom of the fill hole. Add fluid if required.

MAINTENANCE

Gearcase Lubricant

CHECKING/REFILLING GEARCASE LUBRICANT

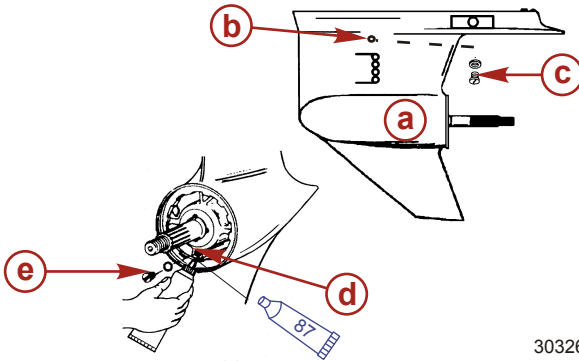

30326

- a - Fleet Master gearcase (vertical operating position)
- b - Vent hole
- c - Vent plug and sealing washer
- d - Fill/drain hole
- e - Fill/drain plug

Tube Ref. No.	Description	Where Used	Part Number
 87	High Performance Gear Lubricant	Fill/Drain Hole	92-802854A1

1. Place the outboard in a vertical operating position.
2. Remove the vent plug (upper plug) and sealing washer.
3. Remove the fill/drain plug (lower plug).
4. Quickly place lubricant tube into the fill hole.
5. Slowly add lubricant until it flows from the (upper) vent hole.
6. Stop adding lubricant. Install the (upper) vent plug and sealing washer before removing the lubricant tube.

IMPORTANT: Replace sealing washers if damaged.

NOTE: Examine the magnetic fill/drain plug for metal particles. A small amount of metal filings or fine metal particles indicates normal gear wear. An excessive amount of metal filings or larger particles (chips) should be checked by an authorized dealer.

MAINTENANCE

7. Remove lubricant tube and reinstall cleaned (lower) fill/drain plug and sealing washer.

Water in gear lubricant may:

- Settle to bottom and drain out with the lubricant
- Be mixed with lubricant giving a milky color to lubricant

Water in gear lubricant will:

- Result in premature bearing failure
- In freezing temperatures, turn to ice and damage gearcase

DRAINING THE GEARCASE

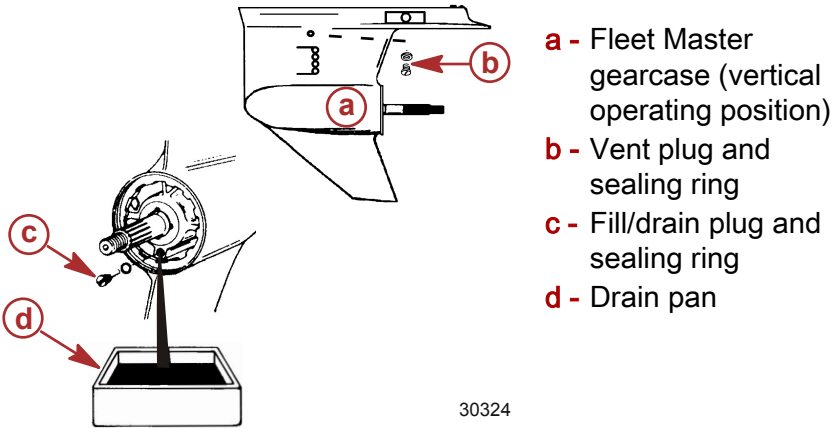

1. Place the outboard in a vertical operating position.
2. Place a drain pan below outboard.
3. Remove the vent plug (upper plug) and sealing ring.
4. Remove the fill/drain plug (lower plug) and sealing ring and drain lubricant.

GEARCASE LUBRICANT CAPACITY

Gearcase lubricant capacity is approximately 710 ml (24 oz).

STORAGE

Protecting External Outboard Components

- Lubricate all outboard components listed in **Maintenance - Inspection and Maintenance Schedule**.
- Touch up any paint nicks. See your dealer for touch-up paint.
- Spray Quicksilver or Mercury Precision Lubricants Corrosion Guard on external metal surfaces (except corrosion control anodes).

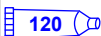
Tube Ref No.	Description	Where Used	Part No.
 120	Corrosion Guard	External metal surfaces	92-802878 55

Gearcase

- Drain and refill the gearcase lubricant (refer to **Gearcase Lubrication**).

Positioning Outboard for Storage

Store outboard in an upright (vertical) position to allow water to drain out of the outboard.

NOTICE

Storing the outboard in a tilted position can damage the outboard. Water trapped in the cooling passages or rain water collected in the propeller exhaust outlet in the gearcase can freeze. Store the outboard in the full down position.

Battery Storage

- Follow the battery manufacturer's instructions for storage and recharging.
- Remove the battery from the boat and check water level. Recharge if necessary.
- Store the battery in a cool, dry place.
- Periodically check the water level and recharge the battery during storage.

TROUBLESHOOTING

Starter Motor Will Not Crank the Engine

POSSIBLE CAUSES

- Blown 20-amp fuse in the starting circuit. Refer to **Maintenance**.
- Outboard is not shifted to neutral position.
- Weak battery or battery connections are loose or corroded.
- Ignition key switch failure.
- Wiring or electrical connection faulty.
- Starter motor solenoid or slave solenoid failure.

Engine Will Not Start

POSSIBLE CAUSES

- Lanyard stop switch not in "RUN" position.
- Battery not fully charged.
- Incorrect starting procedure. Refer to **Operation** section.
- Old or contaminated fuel.
- Fuel is not reaching the engine.
 - Fuel tank is empty.
 - Fuel tank vent not open or restricted.
 - Fuel line is disconnected or kinked.
 - Primer bulb not squeezed.
 - Primer bulb check valve is faulty.
 - Fuel filter is obstructed. Refer to **Maintenance** section.
 - Fuel pump failure.
 - Fuel tank filter obstructed.
- Open 20-amp fuse. Check fuses, refer to **Maintenance** section.
- Threaded connection of an air hose is loose.
- Ignition system component failure.
- Spark plugs fouled or defective. Refer to **Maintenance** section.

TROUBLESHOOTING

Engine Runs Erratically

POSSIBLE CAUSES

- Spark plugs fouled or defective. Refer to **Maintenance** section.
- Incorrect setup and adjustments.
- Fuel is being restricted to the engine.
 - a. Engine fuel filter is obstructed. Refer to **Maintenance** section.
 - b. Fuel tank filter obstructed.
 - c. Stuck antisiphon valve on built-in fuel tank.
 - d. Fuel line is kinked or pinched.
 - e. Injector plugged.
- Threaded connection of an air hose is loose.
- Fuel pump failure.
- Ignition system component failure.

Performance Loss

POSSIBLE CAUSES

- Throttle not opening fully.
- Damaged propeller or improper propeller size.
- Boat overloaded or load improperly distributed.
- Excessive water in bilge.
- Boat bottom is dirty or damaged.
- Faulty knock sensor.
- Warning horn failure.
- Engine block pressure sensor or coolant temperature sensor failure (Guardian is activated).

Warning Horn Activates (With Power Loss)

POSSIBLE CAUSES

- Intermittent horn sound:

TROUBLESHOOTING

- The oil level in the engine-mounted oil reservoir tank is low. Refill the reservoir tank and the remote oil tank. Refer to **Fuel and Oil** for details.
- Battery voltage is out of limits.
- Throttle position sensor failure.
- Continuous horn sound:
 - The oil level in the engine-mounted oil reservoir tank is critically low. Refill the reservoir tank and the remote oil tank. Refer to **Fuel and Oil** for details.
 - The oil pump has failed, halting the oil supply to the engine.
 - Engine speed exceeds the maximum-allowable RPM. The system limits the engine to within the allowable range. If the overspeed condition continues, Engine Guardian places the engine into power reduction. Overspeed may be caused by incorrect propeller pitch, engine height, trim angle, etc.
 - High engine temperature or low block water pressure.
 - Cooling system clogged.
 - Incorrect transom height (water pickups not getting adequate water supply).

Warning Horn Activates (No Power Loss)

POSSIBLE CAUSES

- Warning horn activates on start up. This is normal operation.
- Water is detected in the water-separating fuel filter. Refer to **Maintenance** for procedures on removing water from the filter.

Battery Will Not Hold Charge

POSSIBLE CAUSES

- Battery connections are loose or corroded.
- Low electrolyte level in battery.
- Worn out or inefficient battery.
- Excessive use of electrical accessories.

TROUBLESHOOTING

- Defective rectifier, alternator, or voltage regulator.

OWNER SERVICE ASSISTANCE

Local Repair Service

Always return your outboard to your local authorized dealer should the need for service arise. Only he has the factory trained mechanics, knowledge, special tools, equipment, and genuine parts and accessories to properly service your engine should the need occur. He knows your engine best.

Service Away from Home

If you are away from your local dealer and the need arises for service, contact the nearest authorized dealer. Refer to the Yellow Pages of the telephone directory. If, for any reason, you cannot obtain service, contact the nearest Mercury Marine Service Office.

Parts and Accessories Inquiries

All inquiries concerning genuine replacement parts and accessories should be directed to your local authorized dealer. The dealer has the necessary information to order parts and accessories for you. When inquiring on parts and accessories, the dealer requires the model and serial number to order the correct parts.

Service Assistance

LOCAL REPAIR SERVICE

If you need service for your Mercury-outboard-powered boat, take it to your authorized dealer. Only authorized dealers specialize in Mercury products and have factory-trained mechanics, special tools and equipment, and genuine Quicksilver parts and accessories to properly service your engine.

NOTE: Quicksilver parts and accessories are engineered and built by Mercury Marine specifically for your power package.

OWNER SERVICE ASSISTANCE

SERVICE AWAY FROM HOME

If you are away from your local dealer and the need arises for service, contact the nearest authorized dealer. If, for any reason, you cannot obtain service, contact the nearest Regional Service Center. Outside the United States and Canada, contact the nearest Marine Power International Service Center.

STOLEN POWER PACKAGE

If your power package is stolen, immediately advise the local authorities and Mercury Marine of the model and serial numbers and to whom the recovery is to be reported. This information is maintained in a database at Mercury Marine to aid authorities and dealers in the recovery of stolen power packages.

ATTENTION REQUIRED AFTER SUBMERSION

1. Before recovery, contact an authorized Mercury dealer.
2. After recovery, immediate service by an authorized Mercury dealer is required to reduce the possibility of serious engine damage.

REPLACEMENT SERVICE PARTS

WARNING

Avoid fire or explosion hazard. Electrical, ignition, and fuel system components on Mercury Marine products comply with federal and international standards to minimize risk of fire or explosion. Do not use replacement electrical or fuel system components that do not comply with these standards. When servicing the electrical and fuel systems, properly install and tighten all components.

Marine engines are expected to operate at or near full throttle for most of their lives. They are also expected to operate in both fresh and saltwater environments. These conditions require numerous special parts.

OWNER SERVICE ASSISTANCE

PARTS AND ACCESSORIES INQUIRIES

Direct any inquiries concerning Quicksilver replacement parts and accessories to your local authorized dealer. The dealer has the necessary information to order parts and accessories for you if they are not in stock. Only authorized dealers can purchase genuine Quicksilver parts and accessories from the factory. Mercury Marine does not sell to unauthorized dealers or retail customers. When inquiring about parts and accessories, the dealer requires the **engine model** and **serial numbers** to order the correct parts.

RESOLVING A PROBLEM

Satisfaction with your Mercury product is important to your dealer and to us. If you ever have a problem, question or concern about your power package, contact your dealer or any authorized Mercury dealership. If you need additional assistance:

1. Talk with the dealership's sales manager or service manager. Contact the owner of the dealership if the sales manager and service manager have been unable to resolve the problem.
2. If your question, concern, or problem cannot be resolved by your dealership, please contact the Mercury Marine Service Office for assistance. Mercury Marine will work with you and your dealership to resolve all problems.

The following information will be needed by the Customer Service:

- Your name and address
- Your daytime telephone number
- The model and serial numbers of your power package
- The name and address of your dealership
- The nature of the problem

CONTACT INFORMATION FOR MERCURY MARINE CUSTOMER SERVICE

For assistance, call, fax, or write to the geographic office in your area. Please include your daytime telephone number with mail and fax correspondence.

OWNER SERVICE ASSISTANCE

United States, Canada		
Telephone	English +1 920 929 5040 Français +1 905 636 4751	Mercury Marine W6250 W. Pioneer Road P.O. Box 1939 Fond du Lac, WI 54936-1939
Fax	English +1 920 929 5893 Français +1 905 636 1704	
Website	www.mercurymarine.com	

Australia, Pacific		
Telephone	+61 3 9791 5822	Brunswick Asia Pacific Group 41-71 Bessemer Drive Dandenong South, Victoria 3175 Australia
Fax	+61 3 9706 7228	

Europe, Middle East, Africa		
Telephone	+32 87 32 32 11	Brunswick Marine Europe Parc Industriel de Petit-Rechain B-4800 Verviers, Belgium
Fax	+32 87 31 19 65	

Mexico, Central America, South America, Caribbean		
Telephone	+1 954 744 3500	Mercury Marine 11650 Interchange Circle North Miramar, FL 33025 U.S.A.
Fax	+1 954 744 3535	

Japan		
Telephone	+072 233 8888	Kisaka Co., Ltd. 4-130 Kannabecho Sakai-shi Sakai-ku 5900984 Osaka, Japan
Fax	+072 233 8833	

Asia, Singapore		
Telephone	+65 65466160	Brunswick Asia Pacific Group T/A Mercury Marine Singapore Pte Ltd 29 Loyang Drive Singapore, 508944
Fax	+65 65467789	

Ordering Literature

Before ordering literature, have the following information about your power package available:

OWNER SERVICE ASSISTANCE

Model		Serial Number	
Horsepower		Year	

UNITED STATES AND CANADA

For additional literature for your Mercury Marine power package, contact your nearest Mercury Marine dealer or contact:

Mercury Marine		
Telephone	Fax	Mail
(920) 929-5110 (USA only)	(920) 929-4894 (USA only)	Mercury Marine Attn: Publications Department P.O. Box 1939 Fond du Lac, WI 54935-1939

OUTSIDE THE UNITED STATES AND CANADA

Contact your nearest Mercury Marine authorized service center to order additional literature that is available for your particular power package.

Submit the following order form with payment to:	Mercury Marine Attn: Publications Department W6250 West Pioneer Road P.O. Box 1939 Fond du Lac, WI 54936-1939
--	---

Ship To: (Copy this form and print or type—This is your shipping label)

Name	
Address	
City, State, Province	
ZIP or postal code	
Country	

Quantity	Item	Stock Number	Price	Total
			.	.
			.	.
			.	.
			.	.
			.	.
Total Due				.

OUTBOARD INSTALLATION

Mercury Marine Validated Engine Mounting Hardware

IMPORTANT: Mercury Marine provides validated fasteners and installation instructions, including torque specifications, with all of our outboards so they can be properly secured to boat transoms. Improper installation of the outboard can cause performance and reliability issues that can lead to safety concerns. Follow all of the instructions relating to the outboard installation. **DO NOT** mount any other accessory onto the boat with the fasteners provided with the outboard. For example, do not mount a tow sport bars or boarding ladders onto the boat using the mounting hardware included with the outboard. Installing other products onto the boat that utilize the outboard mounting hardware will compromise the ability of that hardware to properly and safely secure the outboard to the transom.

Outboards that require validated mounting hardware will have the following decal on the transom clamp.



51965

OUTBOARD INSTALLATION

Boat Horsepower Capacity

WARNING

Exceeding the boat's maximum horsepower rating can cause serious injury or death. Overpowering the boat can affect boat control and flotation characteristics or break the transom. Do not install an engine that exceeds the boat's maximum power rating.

Do not overpower or overload your boat. Most boats will carry a required capacity plate indicating the maximum acceptable power and load as determined by the manufacturer following certain federal guidelines. If in doubt, contact your dealer or the boat manufacturer.

U.S. COAST GUARD CAPACITY	
MAXIMUM HORSEPOWER	XXX
MAXIMUM PERSON CAPACITY (POUNDS)	XXX
MAXIMUM WEIGHT CAPACITY	XXX

26777

Start in Gear Protection

WARNING

Starting the engine with the drive in gear can cause serious injury or death. Never operate a boat that does not have a neutral-safety-protection device.

The remote control connected to the outboard must be equipped with a start in neutral only protection device. This prevents the engine from starting in gear.

Selecting Accessories for Your Outboard

Genuine Mercury Precision or Quicksilver Accessories have been specifically designed and tested for this outboard.

OUTBOARD INSTALLATION

Some accessories not manufactured or sold by Mercury Marine are not designed to be safely used with this outboard or outboard operating system. Acquire and read the installation, operation, and maintenance manuals for all selected accessories.

Fuel System

AVOIDING FUEL FLOW RESTRICTION

IMPORTANT: Adding components to the fuel supply system (filters, valves, fittings, etc.) may restrict the fuel flow. This may cause engine stalling at low speed, and/or a lean fuel condition at high RPM that could cause engine damage.

ELECTRIC FUEL PUMP

The fuel pressure must not exceed 28 kPa (4 psi). If necessary, install a pressure regulator.

LOW PERMEATION FUEL HOSE REQUIREMENT

Required for outboards manufactured for sale, sold, or offered for sale in the United States.

- The Environmental Protection Agency (EPA) requires that any outboard manufactured after January 1, 2009, must use low permeation fuel hose for the primary fuel hose connecting the fuel tank to the outboard.
- Low permeation hose is USCG Type B1-15 or Type A1-15, defined as not exceeding $15/\text{gm}^2/24 \text{ h}$ with CE 10 fuel at $23 \text{ }^\circ\text{C}$ as specified in SAE J 1527 - marine fuel hose.

EPA PRESSURIZED PORTABLE FUEL TANK REQUIREMENTS

The Environmental Protection Agency (EPA) requires portable fuel systems that are produced after January 1, 2011, for use with outboard engines to remain fully sealed (pressurized) up to 34.4 kPa (5.0 psi). These tanks may contain the following:

- An air inlet that opens to allow air to enter as the fuel is drawn out of the tank.
- An air outlet that opens (vents) to the atmosphere if pressure exceeds 34.4 kPa (5.0 psi).

OUTBOARD INSTALLATION

FUEL DEMAND VALVE (FDV) REQUIREMENT

Whenever a pressurized fuel tank is used, a fuel demand valve is required to be installed in the fuel hose between the fuel tank and primer bulb. The fuel demand valve prevents pressurized fuel from entering the engine and causing a fuel system overflow or possible fuel spillage.

The fuel demand valve has a manual release. The manual release can be used (pushed in) to open (bypass) the valve in case of a fuel blockage in the valve.

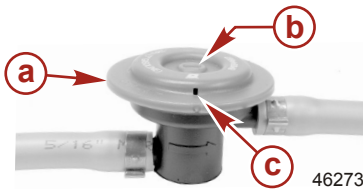

- a** - Fuel demand valve - installed in the fuel hose between the fuel tank and primer bulb
- b** - Manual release
- c** - Vent/water drain holes

FUEL TANKS

Portable Fuel Tank

Select a suitable location in the boat within the engine fuel line length limitations and secure the tank in place.

Permanent Fuel Tank

Permanent fuel tanks should be installed in accordance with industry and federal safety standards, which include recommendations applicable to grounding, anti-siphon protection, ventilation, etc.

FILLING THE FUEL SYSTEM

For the initial start of a new engine, or for an engine that ran out of fuel or was drained of fuel, the fuel system should be filled as follows:

1. Squeeze the fuel line primer bulb until it feels firm.
2. Turn the ignition key switch to the "ON" position for three seconds. This operates the electric fuel pump.

OUTBOARD INSTALLATION

- Turn the ignition key switch back to the "OFF" position, and squeeze the primer bulb again until it feels firm. Turn the ignition key switch to the "ON" position again for three seconds. Continue this procedure until the fuel line primer bulb stays firm.

Installation Specifications

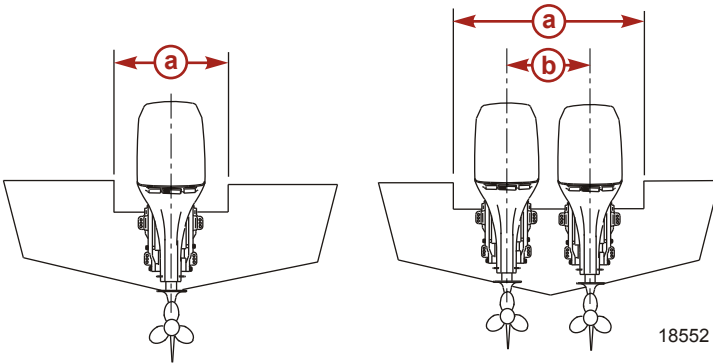

a - Minimum transom opening

b - Engine centerline for dual engine - 66.0 cm (26 in.)

Minimum Transom Opening	
Single engine	84.8 cm (33-3/8 in.)
Dual engine	151.8 cm (59-3/4 in.)

Lifting the Outboard

WARNING

Improperly supporting an engine during lifting can result in the engine falling, causing serious injury or death. Before lifting the engine, verify that the lifting ring is threaded into the flywheel for a minimum of five turns and that the hoist has the correct lifting capacity for the engine weight.

To lift the outboard:

- Remove the cowl from the outboard.

OUTBOARD INSTALLATION

2. Thread the lifting eye into the flywheel hub for a minimum of five turns.

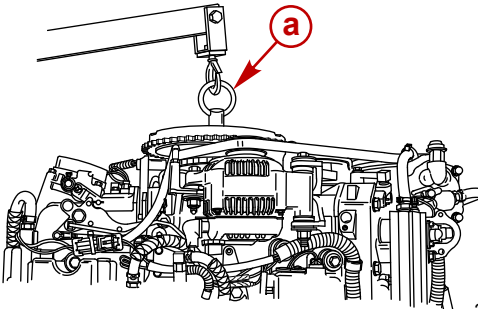

a - Lifting eye

28495

3. Connect a hoist to the lifting eye.
4. Lift the outboard and place it on the boat transom.

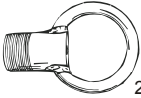
Lifting Eye	91-90455--1
 2756	Threads into the flywheel to remove the powerhead assembly from the driveshaft housing, or to lift entire engine for removal/installation.

Steering Cable - Starboard Side Routed Cable

1. Lubricate the O-ring seal and the entire cable end.

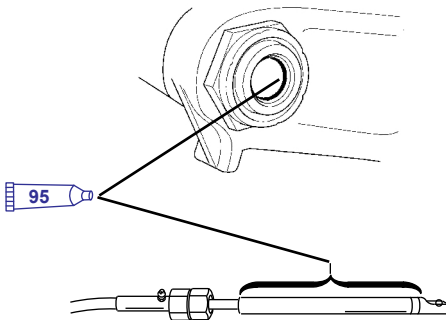

3724

Tube Ref No.	Description	Where Used	Part No.
 95	2-4-C with PTFE	O-ring seal and entire cable end	92-802859A 1

OUTBOARD INSTALLATION

2. Insert the steering cable into the tilt tube.

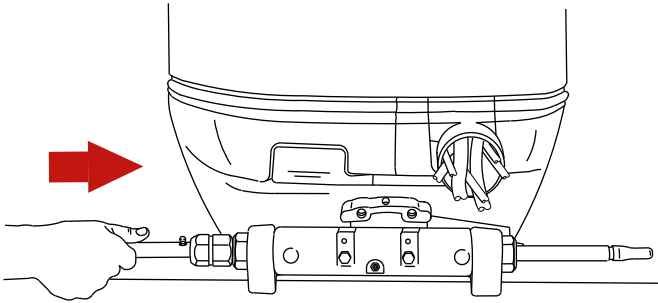

3725

3. Tighten the nut to the specified torque.

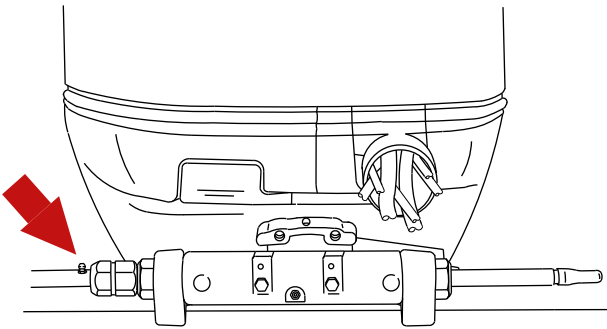

3727

Description	Nm	lb-in.	lb-ft
Nut	47.5	-	35

Steering Link Rod Fasteners

IMPORTANT: The steering link rod that connects the steering cable to the engine must be fastened using a special washer head bolt (P/N 10-849838) and self-locking nylon insert locknuts (P/N 11-826709113). Never replace locknuts with common nuts (nonlocking) as they will work loose and vibrate off, freeing the link rod to disengage.

OUTBOARD INSTALLATION

⚠ WARNING

Improper fasteners or improper installation procedures can result in loosening or disengagement of the steering link rod. This can cause a sudden, unexpected loss of boat control, resulting in serious injury or death due to occupants being thrown within or out of the boat. Always use required components and follow instructions and torque procedures.

⚠ WARNING

Worn, loose, or seized steering components can lead to loss of boat control. Inspect all steering attachment components for wear, lubricate all attachment hardware, and check all fasteners for proper tightness in accordance with the inspection and maintenance schedule.

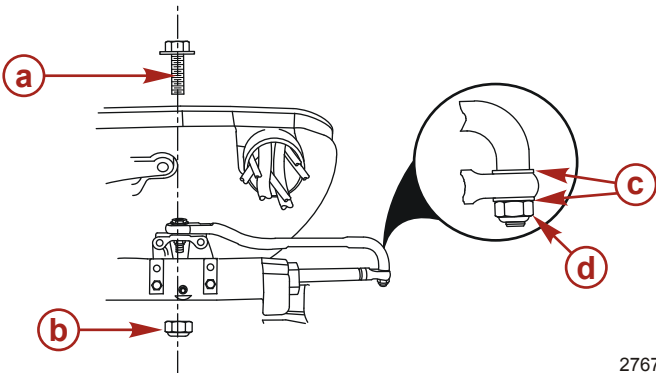

2767

- a** - Special washer head bolt (P/N 10-849838)
 - b** - Nylon insert locknut (P/N 11-826709113) - used on head bolt
 - c** - Flat washer (2)
 - d** - Nylon insert locknut (P/N 11-826709113) - used on cable coupler
1. Assemble steering link rod to steering cable coupler with two flat washers "c" and a self-locking nylon insert locknut "d." Tighten the locknut until it seats, then loosen $\frac{1}{4}$ turn.

OUTBOARD INSTALLATION

2. Assemble the steering link rod to the engine with the special washer head bolt "a" and self-locking nylon insert locknut "b."
3. Torque the head bolt, then the locknut to specifications.

Description	Nm	lb-in.	lb-ft
Cable coupler nylon insert locknut "d"	Tighten locknut until it seats, then loosen $\frac{1}{4}$ turn.		
Head bolt nylon insert locknut "b"	27	–	20
Special washer head bolt	27	–	20

OUTBOARD INSTALLATION

Recommended Mounting Height

DETERMINING OUTBOARD MOUNTING HEIGHT FOR A STANDARD GEAR HOUSING

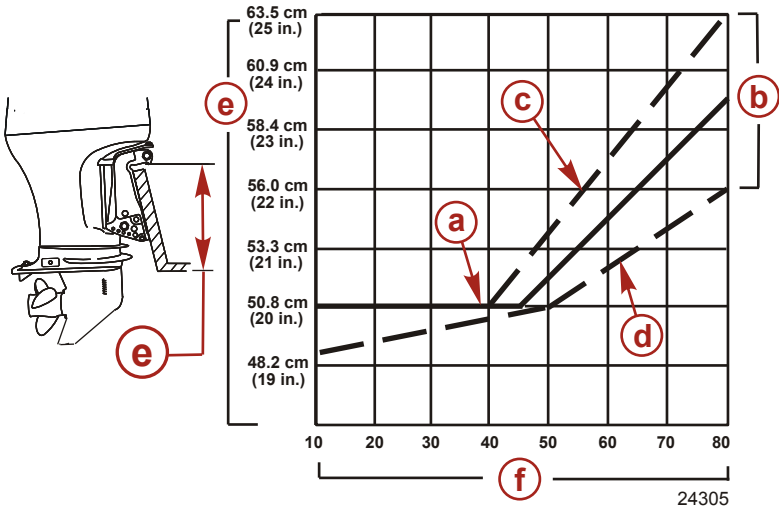

Standard 20-inch (L) mounting bracket graph

- a** - The solid line is recommended to determine the outboard mounting height.
- b** - The broken lines represent the extremes of known successful outboard mounting height dimensions.
- c** - This line may be preferred to determine outboard mounting height dimension, if maximum speed is the only objective.
- d** - This line may be preferred to determine outboard mounting height dimension for dual outboard installation.
- e** - Outboard mounting height (height of outboard mounting brackets from bottom of boat transom). For heights over 56.0 cm (22 in.), a propeller that is designed for piercing the water surface is usually preferred.
- f** - Maximum boat speed anticipated.

OUTBOARD INSTALLATION

NOTICE

1. The outboard should be mounted high enough on the transom so that the exhaust relief hole will stay at least 25.4 mm (1 in.) above the waterline when the engine is running at idle speed. Having the exhaust relief hole above the waterline will prevent exhaust restrictions. Exhaust restrictions will result in poor performance at idle.
2. Add 12.7 cm (5 in.) for XL models to the listed outboard mounting heights.
3. The mounting height of the outboard must not exceed 63.5 cm (25 in.) for L models, 76 cm (30 in.) for XL models. Mounting the outboard higher may cause damage to the gearcase components.

Increasing the mounting height will usually:

- Reduce steering torque
- Increase top speed
- Increase boat stability
- Cause the propeller to break loose during planing

Drilling Outboard Mounting Holes

IMPORTANT: Before drilling any mounting holes, carefully read **Determining Recommended Outboard Mounting Height** and install outboard to the nearest recommended mounting height.

1. Mark four mounting holes on the transom using the transom drilling fixture.

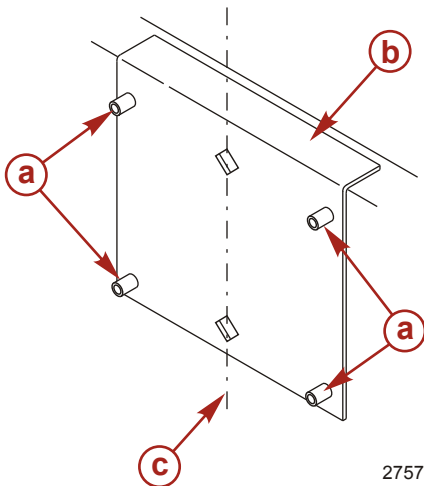

- a** - Drill guide holes
- b** - Transom drilling fixture
- c** - Transom centerline

2757

OUTBOARD INSTALLATION

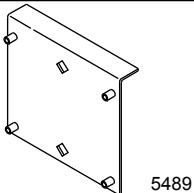
Transom Drilling Fixture	91-98234A2
 <p>5489</p>	Aids in engine installation by acting as a template for engine mounting holes.

2. Drill four 13.5 mm (17/32 in.) mounting holes.

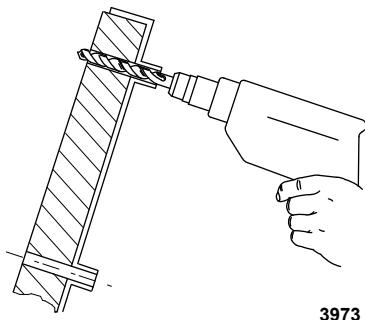

Fastening the Outboard to the Transom

MOUNTING BOLTS

Outboard Transom Mounting Hardware - Supplied with Outboard		
Part Number	Part Name	Description
8M0033366	Outboard mounting bolt	1/2-20 x 5.00 in. long (3.25 in. thread)
826711-17	Nylon insert locknut	1/2-20
28421	Flat washer	1.50 in. diameter
54012	Flat washer	0.875 in. diameter

Available Outboard Mounting Bolts	
Part Number	Description
67755005	1/2-20 x 2.50 in. long (1.25 in. thread)
67755006	1/2-20 x 3.50 in. long (1.25 in. thread)
814259	1/2-20 x 4.00 in. long (2.25 in. thread)
67755-1	1/2-20 x 4.50 in. long (2.25 in. thread)
8M0033366	1/2-20 x 5.00 in. long (3.25 in. thread)

OUTBOARD INSTALLATION

Available Outboard Mounting Bolts	
Part Number	Description
67755-003	½-20 x 5.50 in. long (3.25 in. thread)
67755-2	½-20 x 6.50 in. long (2.75 in. thread)
8M0028080	½-20 x 7.50 in. long (2.75 in. thread)
8M0032860	½-20 x 8.00 in. long (2.75 in. thread)

CHECKING BOAT TRANSOM CONSTRUCTION

IMPORTANT: Determine the strength of the boat transom. The outboard mounting locknuts and bolts should be able to hold 75 Nm (55 lb-ft) of torque without the boat transom yielding or cracking. If the boat transom yields or cracks under this torque, the construction of the transom may not be adequate. The boat transom must be strengthened or the load carrying area increased.

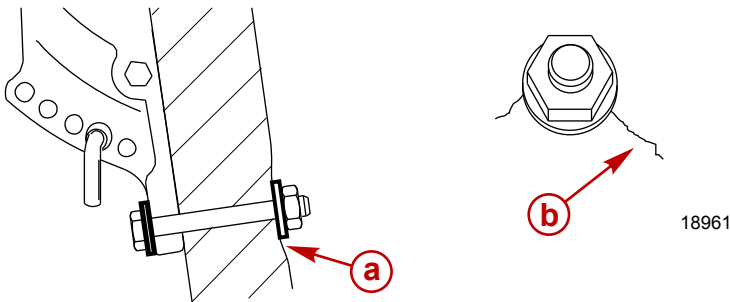

- a** - Transom yielding under bolt torque
- b** - Transom cracking under bolt torque

OUTBOARD INSTALLATION

Use a dial torque wrench to determine transom strength. If the bolt or nut continues to turn without the torque reading on the dial increasing, it is an indication that the transom is yielding. The load area can be increased by using a larger washer or a transom reinforcement plate.

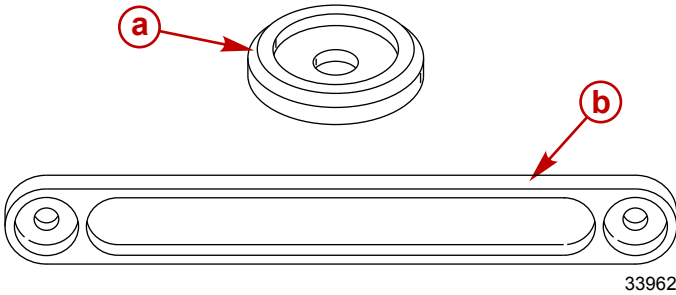

33962

- a** - Large transom washer
- b** - Transom reinforcement plate

OUTBOARD INSTALLATION

FASTENING THE OUTBOARD TO THE TRANSOM

IMPORTANT: The transom mounting surface must be flat within 3.17 mm (0.125 in.). No step in the transom mounting surface is allowed. The inside transom mounting bolt washer surface must be flat within 3.17 mm (0.125 in.).

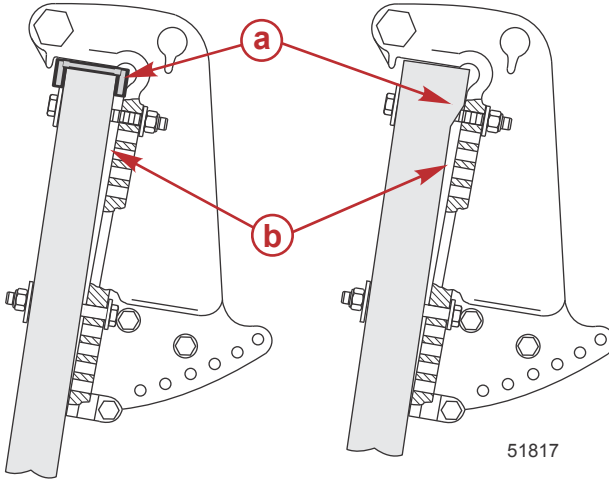

a - Step (not allowed)

b - Gap between transom clamp and boat transom (not allowed)

OUTBOARD INSTALLATION

IMPORTANT: Clearance must be maintained between the vessel transom and the outboard transom bracket relief radius area. Failure to maintain clearance may damage the transom bracket and cause the transom bracket to fail. Adjustments to the position of the Mercury Marine transom drilling fixture may be required to ensure proper clearance of the transom bracket relief radius area.

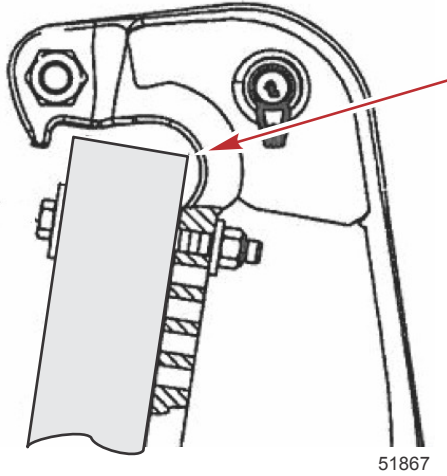

Installation

1. Apply marine sealer to the shanks of the bolts, not to the threads.
2. Fasten the outboard with the correct mounting hardware. Tighten the locknuts to the specified torque.

IMPORTANT: Ensure that a minimum of two full threads of the mounting bolts extend beyond the locknut after tightening. The locknut must be drawn tight while still engaging the bolt threads and not contacting the shank of the bolt.

OUTBOARD INSTALLATION

NOTE: For a more accurate torque reading, tighten the mounting locknuts rather than the outboard mounting bolts.

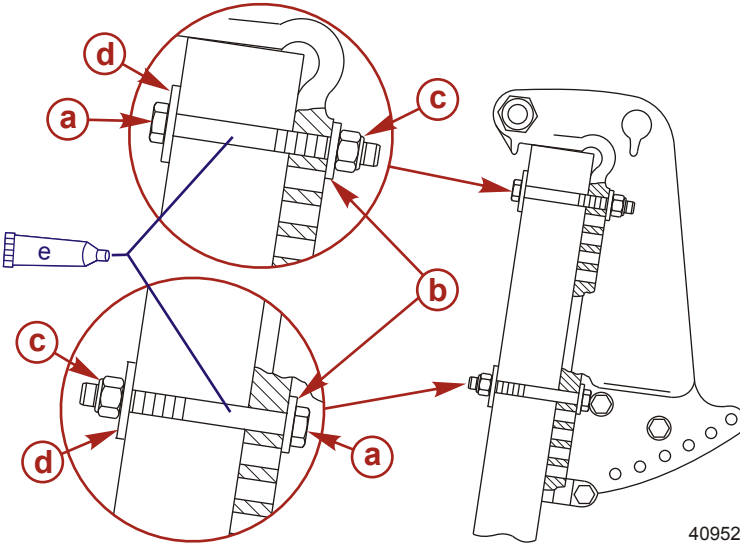

- a** - 0.500 in. diameter outboard mounting bolt (4)
- b** - 0.875 in. flat washer (4)
- c** - Nylon insert locknut (4)
- d** - 1.500 in. flat washer (4)
- e** - Marine sealer – apply to the shank of the bolts, not the threads

Description	Nm	lb-in.	lb-ft
Outboard mounting locknuts and bolts – standard boat transom	75	–	55
Outboard mounting locknuts and bolts – metal lift plates and setback brackets	122	–	90

OUTBOARD INSTALLATION

A decal on the transom bracket reminds the owner to check the fasteners securing the outboard to the transom before each use.

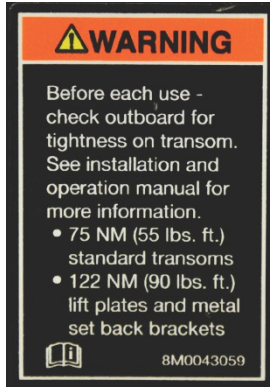

51985

Decal on the transom bracket

Electrical, Hoses, Control Cables, and Front Clamp

REMOTE WIRING HARNESS

Route the remote 14 pin boat harness through the front clamp opening in the bottom cowl. Connect remote harness to the 14 pin connector on the engine harness.

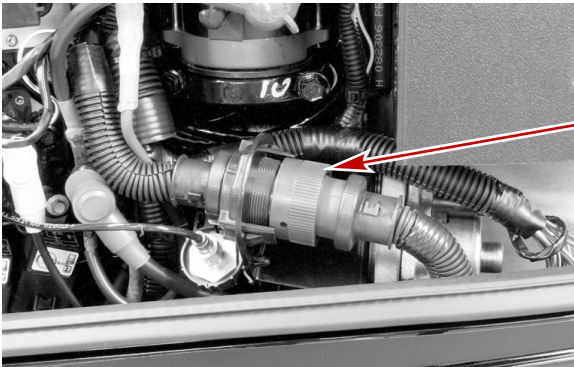

28742

a - 14 pin connector

OUTBOARD INSTALLATION

BATTERY INFORMATION

WARNING

Failure to properly secure the battery leads can result in a loss of power to the Digital Throttle and Shift (DTS) system, leading to serious injury or death due to loss of boat control. Secure the battery leads to the battery posts with hex nuts to avoid loose connections.

- Do not use deep-cycle batteries. Engines must use a marine starting battery with 1000 MCA, 800 CCA, or 180 Ah.
- When connecting the engine battery, hex nuts must be used to secure battery leads to battery posts. Torque nuts to specification.

Description	Nm	lb-in.	lb-ft
Hex nuts	13.5	120	–

IMPORTANT: Battery cable size and length is critical. Refer to engine installation manual for size requirements.

The decal needs to be placed on or near the battery box for future service reference. One 5/16 in. and one 3/8 in. hex nut is supplied per battery for wing nut replacement. Metric hex nuts are not supplied.

NOTICE - DTS & OptiMax Engines

DO NOT USE DEEP CYCLE BATTERIES!
DTS (Digital Throttle and Shift) applications and OptiMax engines must use a marine starting battery with 1000 MCA, 800 CCA, or 180 Ah. rating.

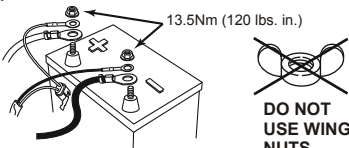

IMPORTANT:
Battery cable size and length is critical. Refer to engine installation manual for size requirements.

37-895387

Place decal on or near battery box for future service reference. 5/16" and 3/8" hex nuts supplied for wing nut replacement. Metric hex nuts not supplied.

3486

OUTBOARD INSTALLATION

BATTERY CABLE CONNECTIONS

Single Outboard

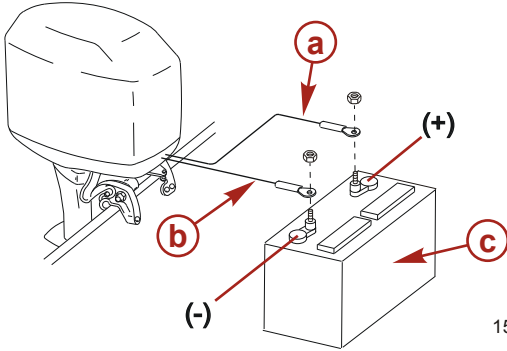

- a** - Red sleeve - positive (+)
- b** - Black sleeve - negative (-)
- c** - Cranking battery

OUTBOARD INSTALLATION

Dual Outboards

Connect a common ground cable (wire size same as engine battery cables) between negative (-) terminals on starting batteries.

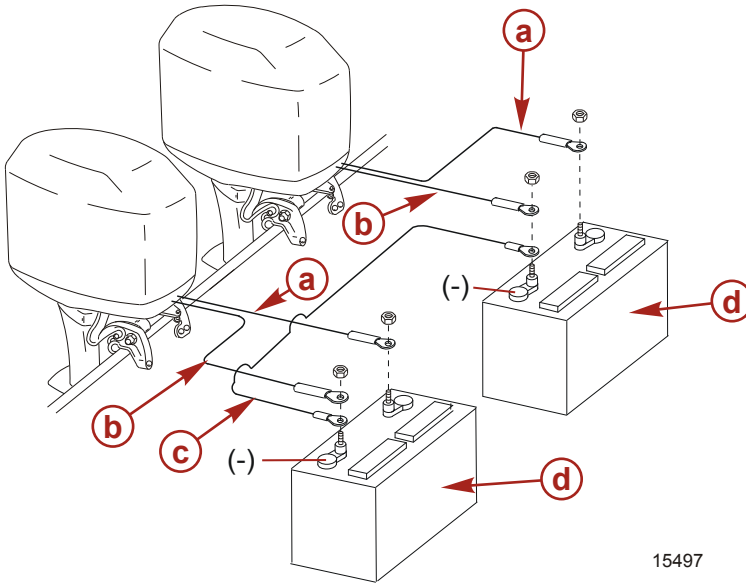

15497

- a** - Red sleeve - positive (+)
- b** - Black sleeve - negative (-)
- c** - Ground cable
- d** - Cranking battery

HOSE AND TUBING CONNECTIONS

Fuel Hose

The minimum fuel line inside diameter (I.D.) is 8 mm (5/16 in.), with a separate fuel line/fuel tank pickup for each engine.

Fasten the remote fuel hose to the fitting with a hose clamp.

Oil Hoses

Connect the remote oil hoses to the engine hose connections.

Fasten hose connections with cable ties.

OUTBOARD INSTALLATION

Water Pressure and Speedometer Hose or Tubing

NOTE: *This applies to models without SmartCraft gauges.*

This outboard has a speedometer water pickup located in the leading edge of the gearcase. If you want to use this water pickup for the speedometer, disconnect the water pickup tubing from the speedometer sensor and route tubing out of the cowl. Install the coupler provided with the outboard on the end of the tubing.

OUTBOARD INSTALLATION

Make the water pressure gauge hose connection to the tubing as shown.

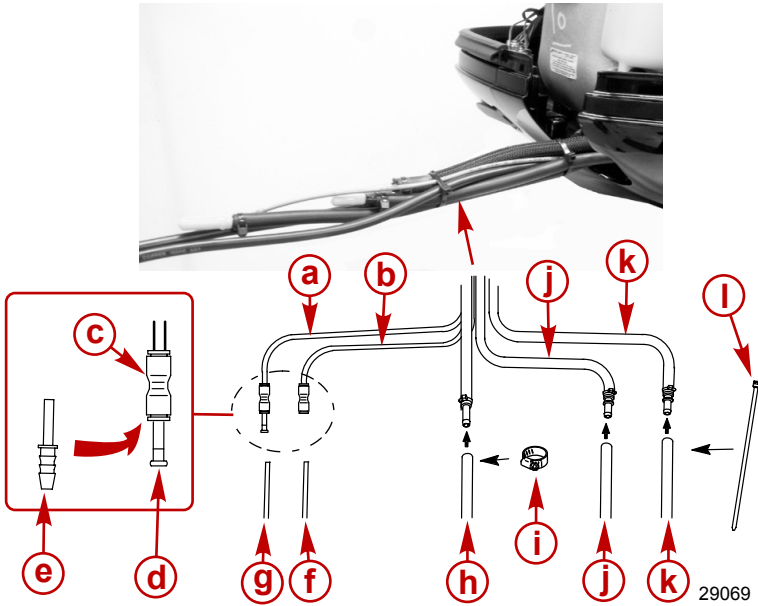

- a** - Water pressure tube
- b** - Speedometer water pickup tube (if required)
- c** - Coupler
- d** - Plug
- e** - Barb hose fitting
- f** - Speedometer hose or tubing
- g** - Water pressure tube
- h** - Remote fuel hose
- i** - Hose clamp
- j** - Oil hose with blue stripe
- k** - Oil hose without blue stripe
- l** - Cable tie

OUTBOARD INSTALLATION

INSTALLING THE SHIFT CABLE

IMPORTANT: The shift cable is the first cable to move when the remote control handle is moved out of neutral, so install/connect it to the engine first.

Locating the Center Point of the Shift Cable

IMPORTANT: Locate the center point of the slack or lost motion that exists in the shift cable for proper adjustment of the shift cable.

1. Mark the forward position as follows:
 - a. Move the remote control handle from neutral into forward and advance the handle to the full speed position. Ensure the throttle control lever is touching the throttle control lever stop screw.
 - b. Slowly return the handle back to the neutral detent position.
 - c. Place a mark on the shift cable against the cable end guide.

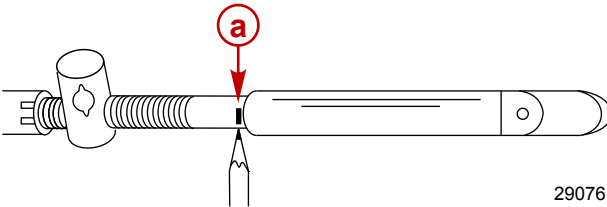

a - Forward position mark

2. Mark the reverse position as follows:
 - a. Move the remote control handle into reverse and advance the handle to the full speed position. Ensure the throttle control lever is touching the throttle control lever stop screw.
 - b. Slowly return the handle back to the neutral detent position.

OUTBOARD INSTALLATION

- c. Place a mark on the shift cable against the cable end guide.

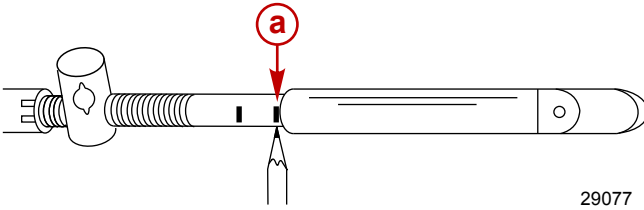

29077

a - Reverse position mark

3. Mark the center on the shift cable midway between the forward and reverse marks.

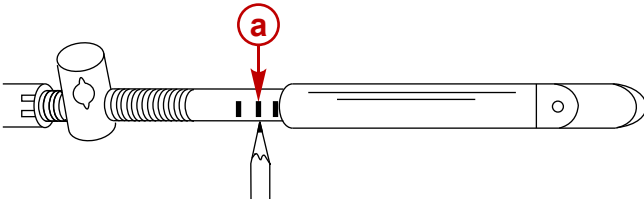

4361

a - Center mark

4. Align the cable end guide against this center mark when installing the cable to the engine.
5. Position the remote control and outboard into neutral position.
6. Slide the anchor pin forward until resistance is felt, then slide the anchor pin toward the rear until resistance is felt.
7. Center the anchor pin between these resistance points.

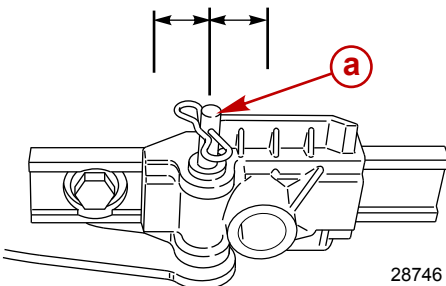

28746

a - Anchor pin

OUTBOARD INSTALLATION

Adjusting the Shift Cable

1. Align the shift cable end guide with the center mark as instructed in **Locating the Center Point of the Shift Cable**.

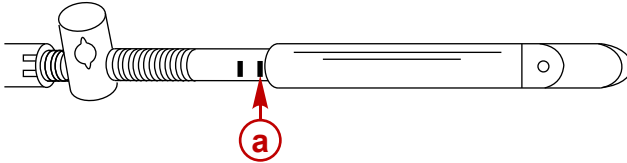

4362

a - Center mark

2. Place the shift cable end guide on the anchor pin and adjust the cable barrel so that it slips freely into the barrel holder.
3. Secure the shift cable to the anchor pin with the retainer clip.

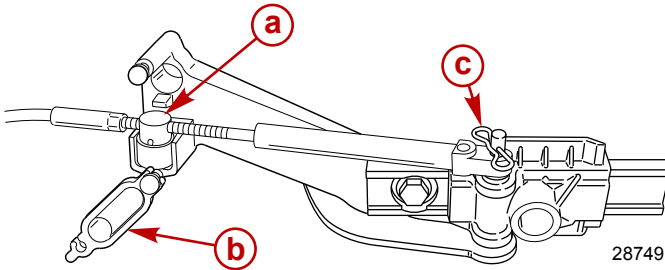

28749

a - Cable barrel
b - Shift cable retainer
c - Retainer clip

4. Check the shift cable adjustments as follows:
 - a. Shift the remote control to forward while turning the propeller shaft. If the propeller shaft does not lock in gear, adjust the cable barrel closer to the cable end guide.
 - b. Shift the remote control into neutral. If the propeller shaft does not turn freely without drag, adjust the barrel away from the cable end guide. Repeat steps a and b.

OUTBOARD INSTALLATION

- c. Shift the remote control into reverse while turning the propeller shaft. If the propeller shaft does not lock solidly in gear, adjust the barrel away from the cable end guide. Repeat steps a through c.
- d. Return the remote control handle to neutral. If the propeller shaft does not turn freely without drag, adjust the barrel closer to the cable end guide. Repeat steps a through d.

INSTALLING THE THROTTLE CABLE

IMPORTANT: Attach the shift cable to the engine prior to attaching the throttle cable.

1. Shift the remote control into the neutral position.
2. Attach the throttle cable to the throttle lever. Secure with a washer and locknut. Tighten the locknut to the specified value.

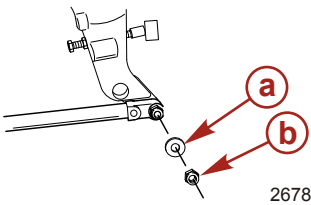

- a** - Nylon washer
b - Locknut

Description	Nm	lb-in.	lb-ft
Throttle cable locknut "b"	Tighten, then loosen 1/4 turn		

OUTBOARD INSTALLATION

3. Adjust the cable barrel so the installed throttle cable will hold the idle stop screw against the stop.

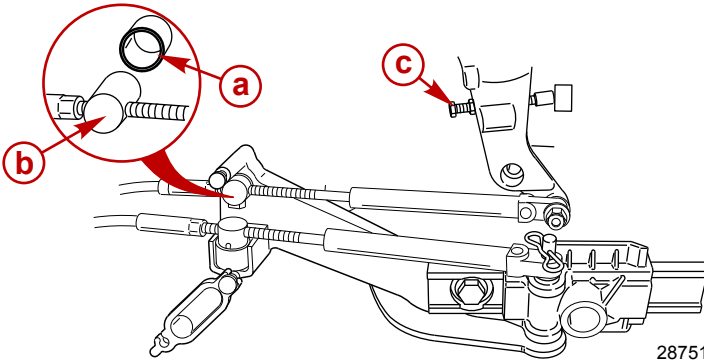

- a** - Barrel sleeve
- b** - Cable barrel
- c** - Idle stop screw

4. Check the throttle cable adjustment as follows:
 - a. Shift the outboard into gear a few times to activate the throttle linkage. Rotate the propeller shaft while shifting into reverse.
 - b. Return the remote control to neutral.
 - c. Place a thin piece of paper between the idle adjustment screw and the idle stop. The adjustment is correct when the paper can be removed without tearing, but has some drag on it.

IMPORTANT: The idle stop screw must be touching the stop.

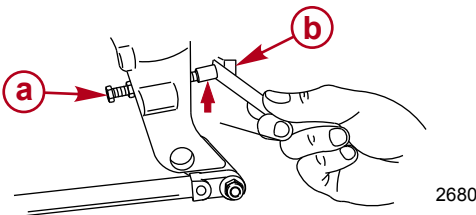

- a** - Idle stop screw
- b** - Idle stop

- d. Adjust the cable barrel if necessary.

OUTBOARD INSTALLATION

5. Lock the barrel holder in place with the cable latch.

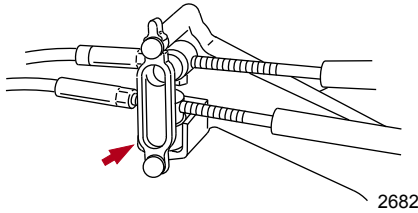

FRONT CLAMP ASSEMBLY INSTALLATION

IMPORTANT: There must be sufficient slack in the engine wiring harness, battery cables, fuel hose, and oil hoses, between clamp and engine attachment point, to relieve stress and prevent hoses from being kinked or pinched.

1. Place the lower half of the front clamp into the bottom cowl opening.
2. Place the neoprene wrap around the wiring, hoses, and control cables, and place into the lower half of the front clamp.

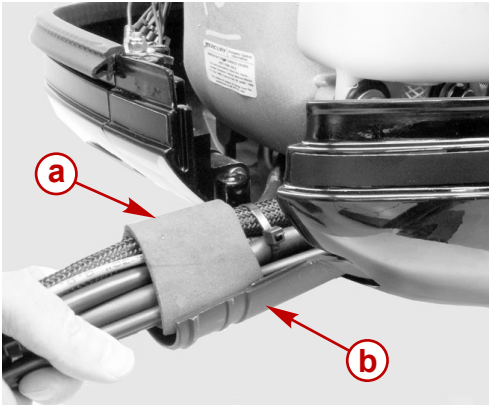

- a** - Neoprene wrap
- b** - Lower half of the front clamp

OUTBOARD INSTALLATION

3. Join the top half of the front clamp with the bottom half. Secure both halves together with cables ties.

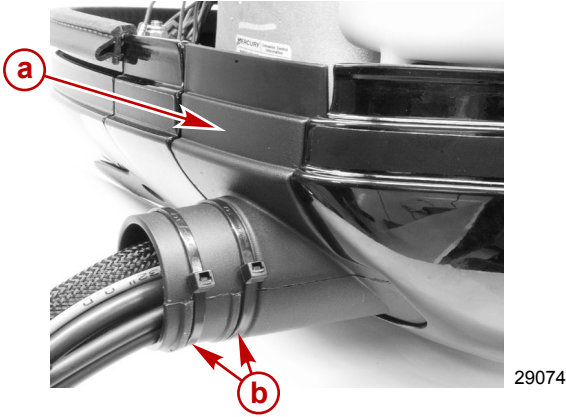

- a** - Top half of the front clamp
- b** - Cable ties

4. Secure the front clamp into the bottom cowl with the retainer and two screws.
5. Install the cowl seal.

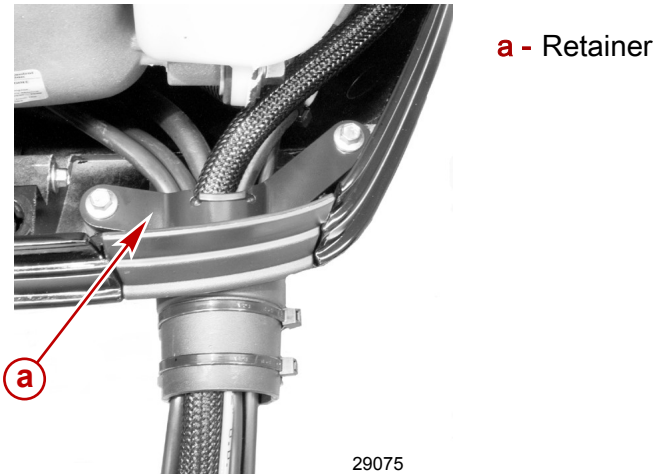

OUTBOARD INSTALLATION

Oil Injection Set-Up

FILLING OIL SYSTEM

1. Fill remote oil tank with the recommended oil listed in the **Operation and Maintenance Manual**. Tighten fill cap.

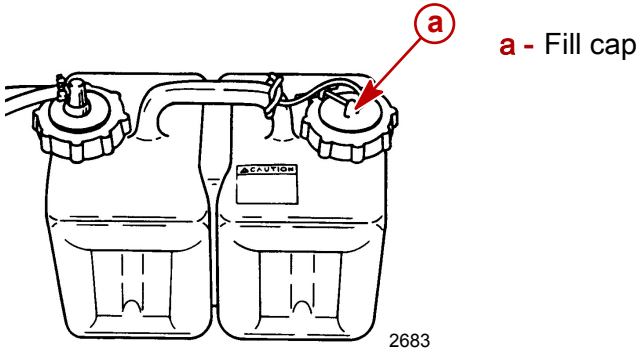

2. Remove cap and fill engine oil tank with oil. Install the fill cap.

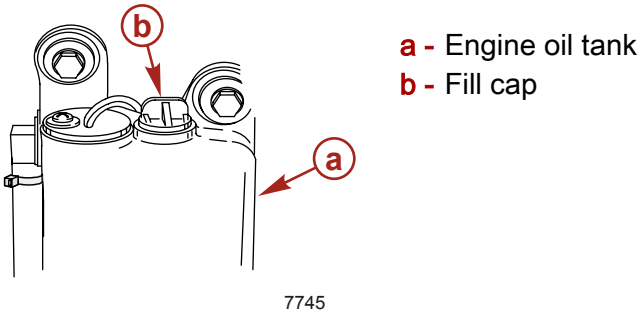

OUTBOARD INSTALLATION

PRIMING OIL INJECTION PUMP

Before starting the engine for the first time, prime the oil injection pump. Priming will remove any air that may be in the pump, oil supply hose, or internal passages.

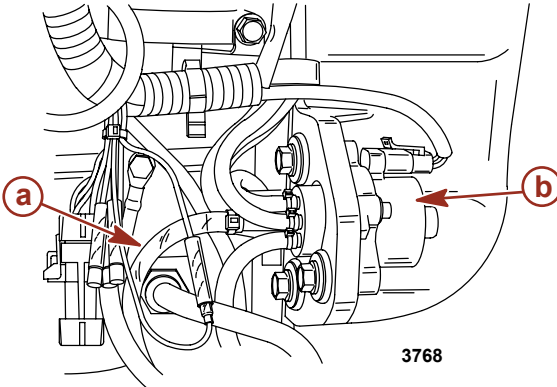

- a** - Oil supply hose
- b** - Oil injection pump

IMPORTANT: Fill the engine fuel system with fuel before priming the oil injection pump. Otherwise, the fuel pump will run without fuel during the priming process and may be damaged.

1. Fill the fuel system.
 - a. Connect fuel hose.
 - b. Fill the fuel system by squeezing the primer bulb.
 - c. Position the fuel line primer bulb so the arrow on the side of the bulb is pointing up. Squeeze the fuel line primer bulb until it feels firm.

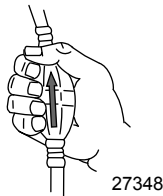

OUTBOARD INSTALLATION

- d. Turn the ignition key switch to the "ON" position for three seconds. This operates the electric fuel pump.

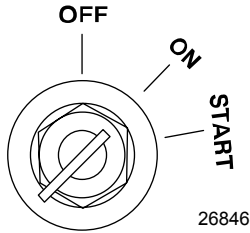

- e. Turn the ignition key switch back to the "OFF" position, and squeeze the primer bulb again until it feels firm.
 - f. Turn the ignition key switch to the "ON" position again for three seconds.
 - g. Continue this procedure until the fuel primer bulb stays firm.
2. Turn the ignition key switch to the "ON" position.
 3. Within the first 10 seconds after the key switch has been turned on, move the remote control handle from neutral into forward. This will automatically start the priming process.

PURGING AIR FROM THE ENGINE OIL TANK

1. Loosen the fill cap on the engine oil tank.
2. Start the engine.
3. Operate the engine until all the air has vented out and oil starts to flow out of the tank.
4. Tighten fill cap.

OUTBOARD INSTALLATION

Trim In Pin

WARNING

Operating the boat at high speeds with the outboard trimmed too far under can create excessive bow steer, resulting in the operator losing control of the boat. Install the trim limit pin in a position that prevents excessive trim under and operate the boat in a safe manner.

Some boats, particularly some bass boats, are built with a greater than normal transom angle, which will allow the outboard to be trimmed further in or under. This greater trim under capability is desirable to improve acceleration, reduce the angle and time spent in a bow high boat during planing off, and in some cases, may be necessary to plane off a boat with aft livewells, given the variety of available propellers and height range of engine installations.

However, once on plane, the engine should be trimmed to a more intermediate position to avoid a bow-down planing condition called plowing. Plowing can cause bow steering or oversteering and inefficiently consumes horsepower.

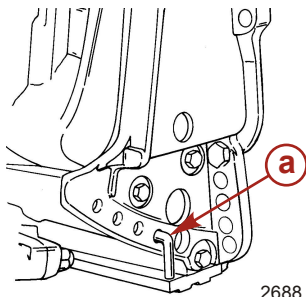

a - Tilt pin (not included with engine)

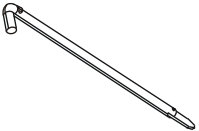
Stainless Steel Tilt Pin	17-49930A 1
 <p>2749</p>	Limits the down trim angle of the power trim equipped engines, or aids in determining the trim out angle on non-power trim engines.

OUTBOARD INSTALLATION

The owner may decide to limit the trim in. This can be accomplished by purchasing a stainless steel tilt pin from your dealer and insert it in whatever adjustment hole in the transom brackets is desired. A nonstainless steel shipping bolt should not be used in this application other than on a temporary basis.

