

Thank You

Thank you for choosing MotorGuide, one of the finest trolling motors available. Years of experience have been committed to the goal of producing the finest quality products. This led to MotorGuide's reputation for strict quality control, excellence, durability, long-lasting performance and being the best at providing after-the-sale service and support.

Please read this manual carefully before operating your motor. This manual has been prepared to assist you in the operation, safe use, and care of your trolling motor.

Again, thank you for your confidence in MotorGuide.

NEVER STOP LEARNING, NEVER STOP IMPROVING, AND NEVER, EVER STOP FISHING.

Warranty Message

The product you have purchased comes with a **Two Year Limited Warranty** from MotorGuide, the terms of the policy are set forth in the **Warranty Information** section of this manual. The policy statement contains a description of the duration of coverage, **important disclaimers and limitations of damages**, and other related information. Please review this important information.

The description and specifications contained herein were in effect at the time this manual was approved for printing. Mercury Marine, whose policy is one of continued improvement, reserves the right to discontinue models at any time, to change specifications, designs, methods, or procedures without notice and without incurring obligation.

MotorGuide, Lowell, Michigan U.S.A.

Litho in U.S.A.

© 2011, MotorGuide

Warranty Information

MotorGuide Limited Two Year Warranty.....	1
---	---

General Information

Boater's Responsibilities.....	4
Protecting People in the Water.....	4
Passenger Safety Message.....	5
Safe Boating Suggestions.....	5

Product Overview

R3-30/R3-40/R3-45/R3-55 MotorGuide Trolling Motor.....	7
Specifications.....	8

Wiring and Battery Information

Wiring and Battery Information.....	9
Standard Practices and Procedures.....	9
Battery Recommendations.....	9
Battery Precautions.....	10
Wire and Cable Routing.....	10
Battery Connection.....	11

Trolling Motor Installation and Operation

Transom Mount Installation.....	12
Stowing and Deploying the Trolling Motor.....	12
Adjusting the Steering Tension.....	15
Adjusting the Motor Depth.....	16
Speed Control.....	17

Maintenance

Trolling Motor Care.....	19
Inspection and Maintenance Schedule.....	19
Lubricating the Pivot Points.....	20
Battery Inspection.....	20
Propeller Replacement.....	21
MotorGuide Accessories Inquiries.....	22

Troubleshooting

Trolling Motor Performance.....	23
---------------------------------	----

Owner Service Assistance

Mercury Marine Service Offices.....	25
-------------------------------------	----

WARRANTY INFORMATION

MotorGuide Limited Two Year Warranty

KEEP YOUR ORIGINAL PURCHASE RECEIPT

1. To obtain warranty service, the purchaser should deliver or return the unit (postage prepaid and insured) to any MotorGuide authorized service dealer. **DO NOT RETURN TO PLACE OF PURCHASE** unless they are an authorized service center. Motors purchased in other countries should be returned to place of purchase. Products returned by mail should also be carefully packaged and include a note describing the nature of the problem and/or service requested, customer address, and phone number. A copy of the receipt, Bill of Sale, registration verification, or other proof of purchase is required with the return of the product for warranty consideration. Warranty claims will not be accepted without presentation of purchase receipt for trolling motor, other verification of registration, or Bill of Sale for boat package.
2. MotorGuide electric trolling motors are warranted to the original purchaser to be free from defects in material and/or workmanship for two (2) years. Warranty is NOT transferable to any subsequent purchaser.
3. MotorGuide, at its discretion, will repair or replace items covered under the terms of this warranty. Neither MotorGuide nor MotorGuide Service Dealers are responsible for damages to MotorGuide products due to repairs performed by anyone other than the MotorGuide Factory Service Center. Neither MotorGuide nor Mercury Marine is responsible for failure or damage caused by improper installation, set-up, preparation, or previous service or repair errors.

WARRANTY INFORMATION

4. Warranty coverage is available only to customers that purchase from a dealer authorized by MotorGuide/Mercury Marine to distribute the product in the country in which the sale occurred. Warranty coverage and duration varies by the country in which the product resides. This warranty applies to R3 series MotorGuide Trolling Motors sold and residing in the United States. This Limited Warranty begins on the date the product is first sold to a purchaser or the date on which the product is first put into service, whichever occurs first. MotorGuide accessories are covered by this Limited Warranty for a coverage period of one (1) year from the date of retail sale. The repair or replacement of parts, or the performance of service under this warranty, does not extend the life of this warranty beyond its original expiration date. Promotional warranties are not included in this statement and coverage may vary by promotion. Product either sold or put into service more than six years from date of manufacture is excluded from warranty coverage.
5. This warranty does not apply to normal worn parts, i.e., worn cables, adjustments, or product damage due to 1) neglect, lack of maintenance, accident, abnormal operation, or improper installation or service; 2) abuse, i.e., bent metal columns, bent armature shafts, broken control cables, etc., accidents, modifications, misuse, excessive wear, or damage caused by an owner's failure to provide reasonable and necessary installation or care; 3) use of an accessory or part not manufactured by MotorGuide/Mercury; 4) alteration or removal of parts; 5) opening the lower unit (motor) by anyone other than the Factory Service Center will void this warranty.
6. This warranty will not apply to haul-out, launch, towing and storage, transportation charges and/or travel time, telephone or rental charges of any type, inconvenience, or loss of time or income, or other consequential damages.
7. We reserve the right to improve the design of any Trolling Motor without assuming any obligation to modify any Trolling Motor previously manufactured.

WARRANTY INFORMATION

8. Serialized "Service-Repair" motors have a one (1) year warranty. Nonserialized "Service-Repair" electric trolling motors are NOT warranted. "Service-Repair" motor denotes a trolling motor sold by MotorGuide that may be "used," but has been inspected and may have had minor repairs. Original retail purchaser of a "Service-Repair" motor is the first purchaser of the motor after it is denoted as "Service-Repair." "Service-Repair" motors have a blue sticker on the battery cable and box denoting "Manufacturer Certified Service-Repair Motor."
9. TERMINATION OF COVERAGE: Warranty coverage may be terminated for repossessed product, or product purchased at auction, from a salvage yard, from a liquidator, from an insurance company, from unauthorized marine dealers or boatbuilders, or other third party entities.
10. ALL INCIDENTAL AND/OR CONSEQUENTIAL DAMAGES ARE EXCLUDED FROM THIS WARRANTY, WARRANTIES OF MERCHANTABILITY AND FITNESS ARE EXCLUDED FROM THIS WARRANTY, IMPLIED WARRANTIES ARE LIMITED TO THE LIFE OF THIS WARRANTY, SOME STATES DO NOT ALLOW LIMITATIONS ON HOW LONG AN IMPLIED WARRANTY LASTS OR THE EXCLUSION OR LIMITATION OF INCIDENTAL OR CONSEQUENTIAL DAMAGES, SO THE ABOVE LIMITATIONS OR EXCLUSIONS MAY NOT APPLY TO YOU. THIS WARRANTY GIVES YOU SPECIFIC LEGAL RIGHTS, AND YOU MAY ALSO HAVE OTHER LEGAL RIGHTS WHICH MAY VARY FROM STATE TO STATE.

GENERAL INFORMATION

Boater's Responsibilities

The operator (driver) is responsible for the correct and safe operation of the boat and safety of its occupants and general public. It is strongly recommended that each operator (driver) read and understand this entire manual before operating the trolling motor.

Be sure at least one additional person on board is instructed in the basic operation of the trolling motor in case the driver is unable to operate the boat.

Protecting People in the Water

WHILE YOU ARE TROLLING

It is very difficult for a person in the water to take quick action to avoid a boat heading in their direction, even at slow speeds.



Always slow down and exercise extreme caution any time you are boating in an area where there might be people in the water.

WHILE THE BOAT IS STATIONARY

WARNING

A spinning propeller, a moving boat, or any solid device attached to the boat can cause serious injury or death to swimmers. Stop the trolling motor immediately whenever anyone in the water is near your boat.

Shut off the trolling motor before allowing people to swim or be in the water near your boat.

GENERAL INFORMATION

Passenger Safety Message

Whenever the boat is in motion, observe the location of all passengers. A sudden reduction in boat speed, such as a sharp change of boat direction, could throw them off the boat.

Safe Boating Suggestions

In order to safely enjoy the waterways, familiarize yourself with local and other governmental boating regulations and restrictions, and consider the following suggestions.

Use flotation devices. It is the law to have an approved personal flotation device of suitable size for each person aboard and have it readily accessible.

Do not overload your boat. Most boats are rated and certified for maximum load (weight) capacities, refer to your boat capacity plate. If in doubt, contact your dealer or the boat's manufacturer.

Perform safety checks and required maintenance. Follow a regular schedule and ensure all repairs are made properly.

Never be under the influence of alcohol or drugs while boating (it is the law). Alcohol or drug use impairs your judgment and greatly reduces your ability to react quickly.

Passenger boarding. Stop the trolling motor whenever passengers are boarding or unloading.

Be alert. The operator of the boat is responsible by law to maintain a proper lookout by sight and hearing. The operator must have an unobstructed view particularly to the front. No passengers, load, or fishing seats should block the operators view when operating the boat.

Underwater hazards. Reduce speed and proceed with caution whenever navigating in shallow water.

Tripping hazards. To avoid a trip hazard, route all cables and wiring neatly and out of the way.

GENERAL INFORMATION

Report accidents. Boat operators are required by law to file a Boating Accident Report with their state boating law enforcement agency when their boat is involved in certain boating accidents. A boating accident must be reported if 1) there is loss of life or probable loss of life, 2) there is personal injury requiring medical treatment beyond first aid, 3) there is damage to boats or other property where the damage value exceeds \$500.00 or 4) there is complete loss of the boat. Seek further assistance from local law enforcement.

PRODUCT OVERVIEW

R3-30/R3-40/R3-45/R3-55 MotorGuide Trolling Motor

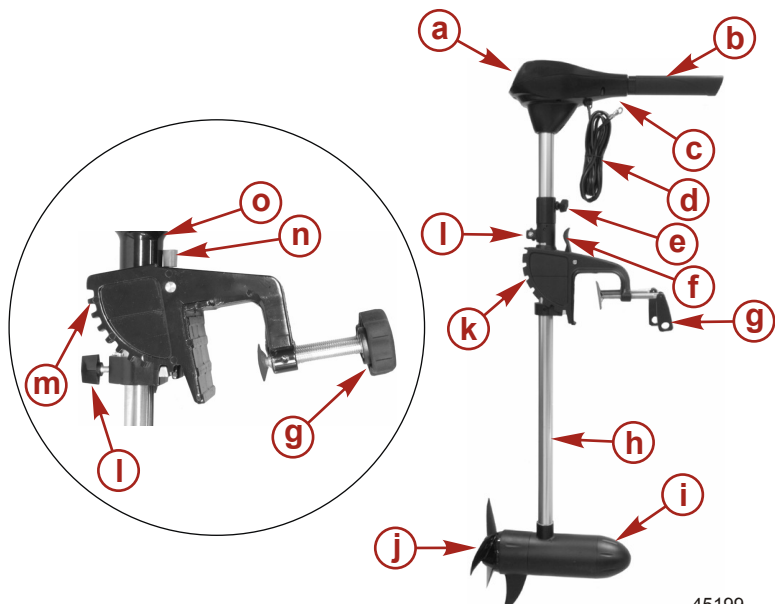

45199

- a** - Top housing
- b** - Extendable speed control tiller handle
- c** - Serial number
- d** - Positive and negative battery leads
- e** - Depth adjustment collar (R3-45/55 model shown)
- f** - Tilt lock release lever (R3-45/55 model shown)
- g** - Transom clamp screws
- h** - Column
- i** - Lower unit
- j** - Propeller
- k** - Clamp bracket (R3-45/55 model shown)
- l** - Steering tension collar
- m** - Clamp bracket assembly (R3-30/40 model shown)
- n** - Tilt lock release button (R3-30/40 model shown)
- o** - Collar (R3-30/40 model shown)

PRODUCT OVERVIEW

Specifications

Model	Peak Thrust	Shaft	Volts	Speed	Control
R3-30	13.6 kgf (30 lbf)	76.2 cm (30 in.)	12 V	5/2	Extendable Hand/ Twist-Tiller
R3-40	18.1 kgf (40 lbf)	91.4 cm (36 in.)	12 V	5/2	Extendable Hand/ Twist-Tiller
R3-45	20.4 kgf (45 lbf)	91.4 cm (36 in.)	12 V	5/2	Extendable Hand/ Twist-Tiller
R3-55	24.9 kgf (55 lbf)	91.4 cm (36 in.)	12 V	5/2	Extendable Hand/ Twist-Tiller

WIRING AND BATTERY INFORMATION

Wiring and Battery Information

WARNING

An operating or charging battery produces gas that can ignite and explode, spraying out sulfuric acid, which can cause severe burns. Ventilate the area around the battery and wear protective equipment when handling or servicing batteries.

WARNING

Performing service or maintenance without first disconnecting the battery can cause product damage, personal injury, or death due to fire, explosion, electrical shock, or unexpected motor starting. Always disconnect the battery cables from the battery before maintaining, servicing, installing, or removing motor components.

Standard Practices and Procedures

When installing or removing this trolling motor, follow these guidelines:

- Disconnect the trolling motor from the trolling motor battery.
- Do not use the main engine battery to power the trolling motor.

Battery Recommendations

- Use a 12 volt, deep cycle marine battery.
- Install a 50 amp manual reset circuit breaker in line with the trolling motor positive leads within 180 cm (72 in.) of the batteries.
- If extending the existing wire beyond the standard battery cable, use 13 mm (6 gauge) battery cables.

Recommended MotorGuide Accessory Description	Part Number
6 gauge battery cable and terminals with 50 amp manual reset breaker	MM309922T
50 amp manual reset breaker	MM5870

WIRING AND BATTERY INFORMATION

Battery Precautions

WARNING

An operating or charging battery produces gas that can ignite and explode, spraying out sulfuric acid, which can cause severe burns. Ventilate the area around the battery and wear protective equipment when handling or servicing batteries.

When charging batteries, an explosive gas mixture forms in each cell. Part of this gas escapes through holes in the vent plugs and may form an explosive atmosphere around the battery if ventilation is poor. This explosive gas may remain in or around the battery for several hours after it has been charged. Sparks or flames can ignite this gas and cause an internal explosion, which may shatter the battery.

The following precautions should be observed to prevent an explosion:

1. Do not smoke near batteries being charged or which have been charged very recently.
2. Do not break live circuits at terminals of batteries, because a spark usually occurs at the point where a live circuit is broken. Always be careful when connecting or disconnecting cable clamps on chargers. Poor connections are a common cause of electrical arcs which cause explosions.
3. Do not reverse polarity of battery terminal to cable connections.

Wire and Cable Routing

- Route the trolling motor wires on the opposite side of the boat from other boat wiring.
- Sensitive electronics, such as depth finders, should be connected directly to the main engine battery. Single battery systems require separate connection cables.

WIRING AND BATTERY INFORMATION

Battery Connection

⚠ CAUTION

Disconnecting or connecting the battery cables in the incorrect order can cause injury from electrical shock or can damage the electrical system. Always disconnect the negative (-) battery cable first and connect it last.

12-VOLT BATTERY CONNECTION

1. Install a 50 amp manual reset circuit breaker in line with the trolling motor power cable positive (+) lead and the battery positive (+) terminal. Connect the trolling motor positive lead to the trolling motor battery positive (+) terminal.
2. Connect the black trolling motor power cable negative (-) lead to the trolling motor battery negative (-) terminal.
3. Connect a common ground bond from the trolling motor battery negative (-) terminal to the engine starting battery negative (-) terminal.

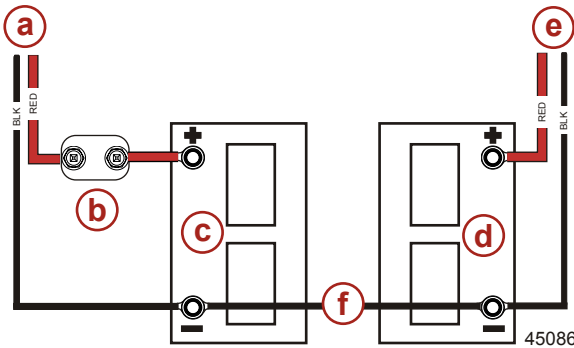

- a** - Power cables to trolling motor
- b** - 50 amp manual reset circuit breaker
- c** - Trolling motor battery
- d** - Engine starting battery
- e** - Power cables to engine
- f** - Common ground bond

Recommended MotorGuide Accessory Description	Part Number
50 amp manual reset breaker	MM5870

TROLLING MOTOR INSTALLATION AND OPERATION

Transom Mount Installation

NOTE: The R3-30 and R3-40 fit transoms up to 7.62 cm (3 in.). The R3-45 and R3-55 fit transoms up to 8.9 cm (3.5 in.).

1. Place the trolling motor on the transom of the boat.

IMPORTANT: Overtightening the transom clamp screws can weaken or damage the mount bracket.

2. Tighten the transom clamp screws securely by hand.

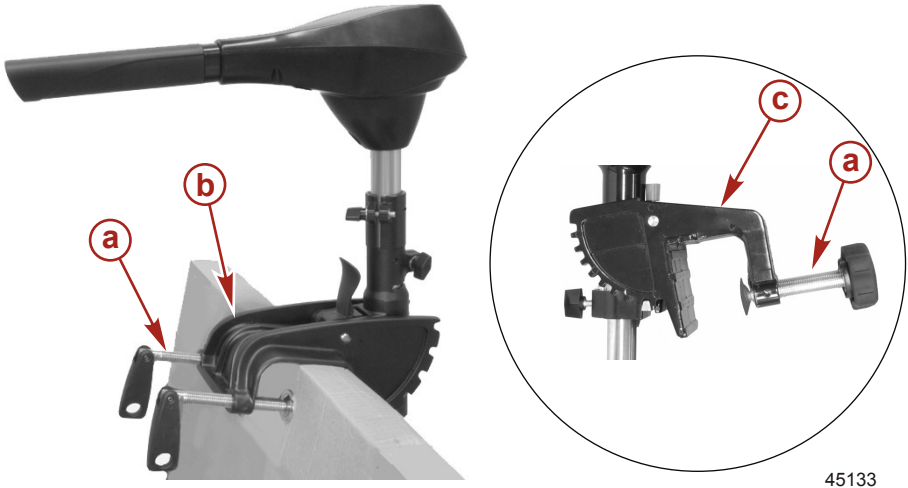

45133

- a** - Transom clamp screw
- b** - Mount bracket (R3-45/55 model shown)
- c** - Mount bracket (R3-30/40 model shown)

Stowing and Deploying the Trolling Motor

⚠ WARNING

Rotating propellers can cause serious injury or death. Never start or operate the motor out of water.

TROLLING MOTOR INSTALLATION AND OPERATION

STOWING THE MOTOR

⚠ CAUTION

Moving parts, such as hinges and pivot points, can cause serious injury. Keep away from moving parts when stowing, deploying, or tilting the motor.

1. To change the drive angle or tilt the trolling motor:
 - R3-30 and R3-40 models - push down on the tilt lock release pin while simultaneously pulling on the trolling motor head/column. Do not exert downward force on the tiller handle to assist in tilting the trolling motor.
 - R3-45 and R3-55 models - push aft on the tilt lock release lever while simultaneously pulling on the trolling motor head/column. Do not exert downward force on the tiller handle to assist in tilting the trolling motor.

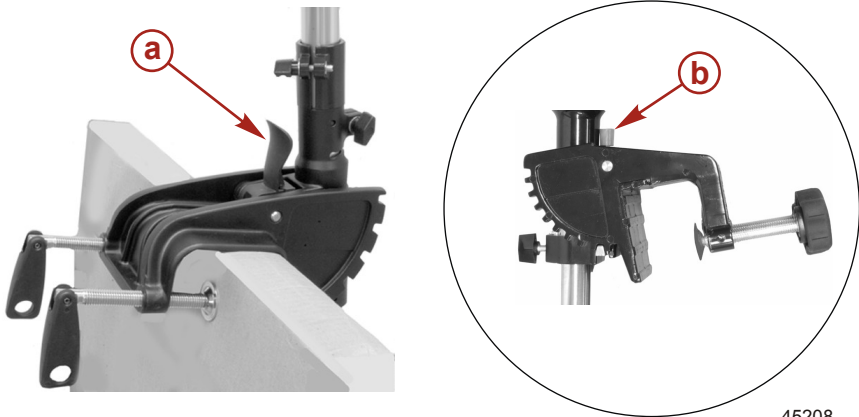

a - Tilt lock release lever (R3-45 and R3-55 model shown)

b - Tilt lock release pin (R3-30 and R3-40 model shown)

TROLLING MOTOR INSTALLATION AND OPERATION

- When the desired tilt position is achieved, release the tilt lock release pin/lever. Verify that the latch pin is securely engaged.

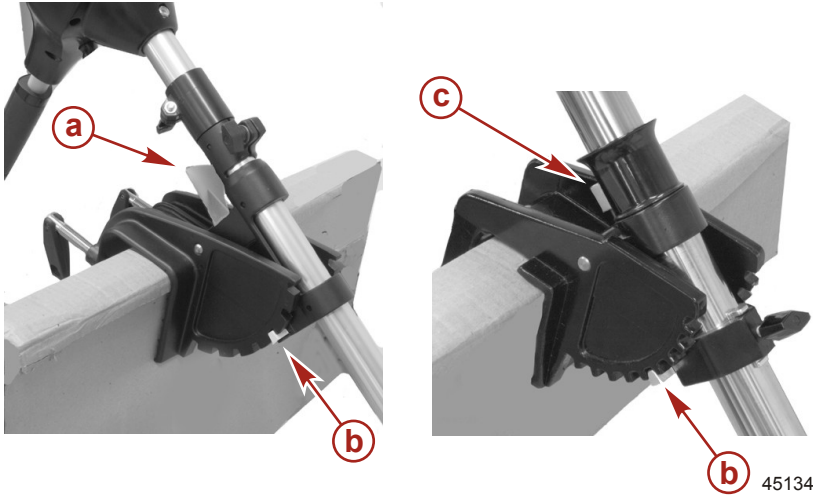

- a** - Tilt lock release lever (R3-45 and R3-55 model shown)
- b** - Latch pin
- c** - Tilt lock release pin (R3-30 and R3-40 model shown)

DEPLOYING THE MOTOR

CAUTION

Moving parts, such as hinges and pivot points, can cause serious injury. Keep away from moving parts when stowing, deploying, or tilting the motor.

TROLLING MOTOR INSTALLATION AND OPERATION

1. Firmly grasp the trolling motor head/column and press on the tilt lock release pin/lever.

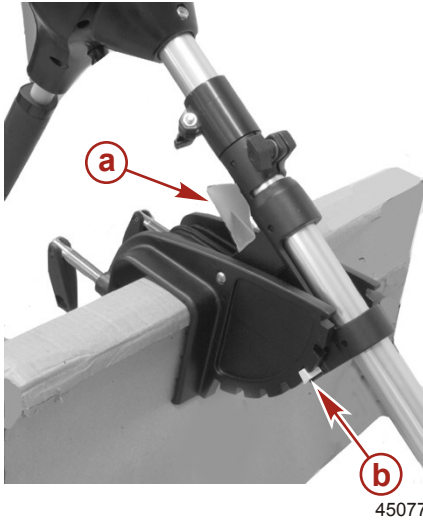

a - Tilt lock release lever (R3-45 and R3-55 models shown)

b - Latch pin

2. Adjust the angle of the motor to the desired position.
3. Release the tilt positioning pin/lever. Verify that the latch pin is securely engaged.

Adjusting the Steering Tension

1. Turn the steering tension knob clockwise to increase steering effort.

TROLLING MOTOR INSTALLATION AND OPERATION

2. Turn the steering tension knob counterclockwise to decrease steering effort.

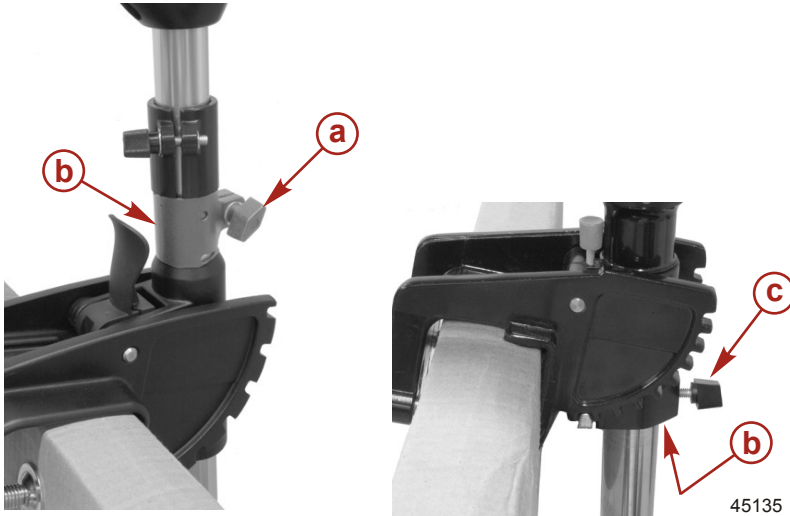

- a** - Steering tension knob (R3-45 and R3-55 model shown)
- b** - Friction strip
- c** - Steering tension knob (R3-30 and R3-40 model shown)

Adjusting the Motor Depth

Adjusting the depth of the motor improves trolling motor performance in various water depths.

NOTE: *It may be necessary to loosen the steering tension knob before adjusting the motor depth. High steering tension will prevent the motor column from moving up and down freely.*

TROLLING MOTOR INSTALLATION AND OPERATION

Firmly grasp the column with one hand while turning the depth collar adjustment knob counterclockwise until the motor column slides freely. To secure the column in the desired depth position, turn the depth collar adjustment knob clockwise and tighten securely. Readjust steering tension if necessary.

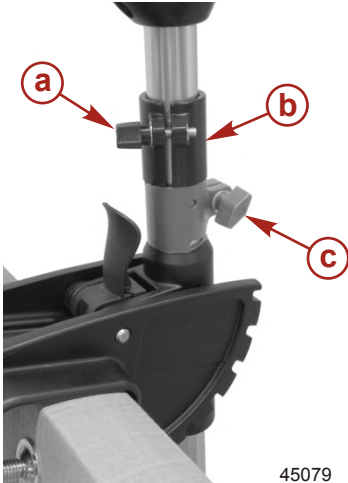

- a** - Depth collar adjustment knob
- b** - Depth collar
- c** - Steering tension knob (R3-45 and R3-55 model shown)

45079

IMPORTANT: When adjusting the motor depth, ensure the lower unit is submerged 25 cm (9.8 in.) to avoid propeller cavitation in choppy water.

Speed Control

Adjust the speed control (five forward speeds and two reverse speeds) to the desired direction and thrust level.

TROLLING MOTOR INSTALLATION AND OPERATION

Rotate the twist-tiller handle clockwise for forward movement and counterclockwise for reverse movement. The "off" handle position stops the motor.

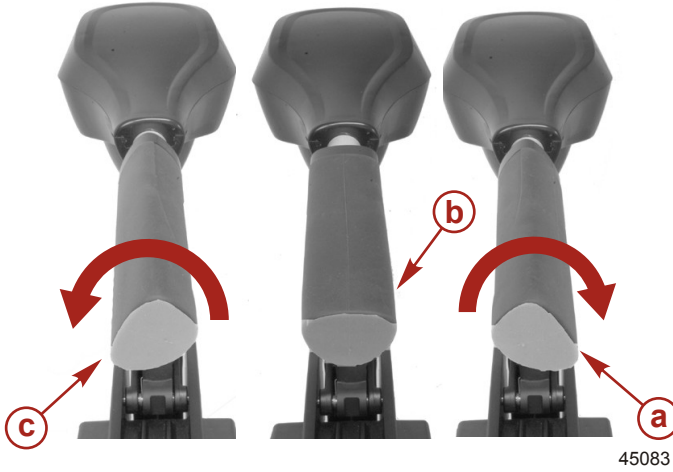

- a** - Forward speed control (five speeds clockwise)
- b** - Off
- c** - Reverse speed control (two speeds counterclockwise)

MAINTENANCE

Trolling Motor Care

To keep your trolling motor in the best operating condition and retain its dependability, it is important that your trolling motor receive periodic inspections and maintenance. We urge you to keep it maintained properly to ensure the safety of you and your passengers.

WARNING

Neglecting to inspect, maintain, or repair your trolling motor can result in product damage or serious injury or death. Do not perform maintenance or service on your trolling motor if you are not familiar with the correct service and safety procedures.

SELECTING REPLACEMENT PARTS

We recommend using original MotorGuide Certified Tough replacement parts.

Inspection and Maintenance Schedule

BEFORE EACH USE

- Check the trolling motor for tightness on the transom.
- Check the tightness of the battery lead connections.
- Visually inspect for loose or corroded wiring connections.
- Check the tightness of the propeller nut.
- Check the propeller blades for damage.

AFTER EACH USE

- Disconnect the battery cables from the power source.
- Check the propeller and the propeller shaft for debris such as weeds and fishing line. Remove all debris.
- Rinse the trolling motor with clean water to remove dirt and dust that may scratch the surface.

EVERY 100 HOURS OF USE OR ANNUALLY

- Periodically lubricate all the pivot points. Refer to **Lubricating the Pivot Points**.
- Check the tightness of bolts, nuts, and other fasteners.
- Inspect the battery. Refer to **Battery Inspection**.

MAINTENANCE

STORAGE PREPARATION

The major consideration in preparing the trolling motor for storage is to protect it from corrosion and damage caused by freezing of trapped water.

Complete the appropriate care instructions to prepare the trolling motor for storage. Store the trolling motor in a dry location where it will not be affected by temperatures below $-29\text{ }^{\circ}\text{C}$ ($-20\text{ }^{\circ}\text{F}$).

IMPORTANT: Trolling motors stored in temperatures below $0\text{ }^{\circ}\text{C}$ ($32\text{ }^{\circ}\text{F}$) should be operated slowly for a minimum of 15 minutes before going above 30% operation.

Lubricating the Pivot Points

To reduce friction, lubricate the following pivot points periodically:

- Pivot pin
- Latch pin
- Tilt positioning pin/lever
- Tilt positioning pin/lever spring

IMPORTANT: Never use an aerosol lubricant to grease or oil any part of the unit. Many aerosol lubricants contain harmful propellants that can cause damage to various parts of the trolling motor.

Tube Ref No.	Description	Where Used	Part No.
 95	2-4-C with PTFE	Pivot points	92-802859A 1

Battery Inspection

The battery should be inspected at periodic intervals to ensure proper trolling motor operation.

IMPORTANT: Read the safety and maintenance instructions which accompany your battery.

1. Ensure that the battery is secured to the vessel.
2. Ensure that the battery cable terminals are clean, tight, and correctly installed. For installation instructions, refer to **Battery Connection**.

MAINTENANCE

3. Ensure that the battery is equipped with a battery box to prevent accidental shorting of the battery terminals.

Propeller Replacement

WARNING

Performing service or maintenance without first disconnecting the battery can cause product damage, personal injury, or death due to fire, explosion, electrical shock, or unexpected motor starting. Always disconnect the battery cables from the battery before maintaining, servicing, installing, or removing motor components.

REMOVING THE PROPELLER

1. Disconnect the power cables from the battery.
2. While holding the propeller blade with one hand, use a propeller wrench to remove the propeller nut.

IMPORTANT: Remove the propeller nut with a propeller wrench. Using another tool may damage the propeller nut or shaft. If the propeller cannot be removed easily, use a rubber mallet to lightly tap the back side of the opposite blade. If the propeller cannot be removed, have the propeller removed by an authorized dealer.

MAINTENANCE

NOTE: If the propeller pin is bent, replace the propeller pin.

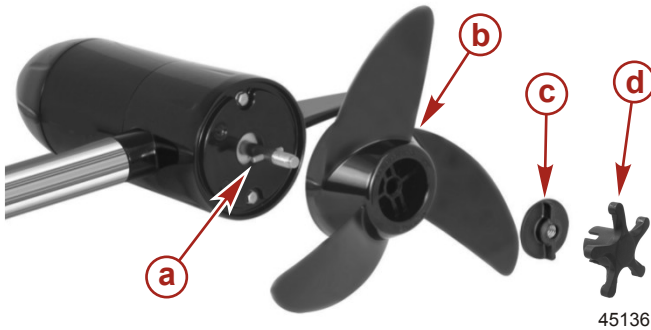

- a** - Propeller pin
- b** - Propeller
- c** - Propeller nut
- d** - Prop wrench

Recommended MotorGuide Accessory Description	Part Number
MotorGuide Prop Wrench Kit	MGA050B6

INSTALLING THE PROPELLER

1. Rotate the motor shaft to insert the propeller pin horizontally.
2. Install the propeller onto the motor shaft by engaging the propeller onto the propeller pin.
3. Install the propeller nut. Tighten securely.
4. Use the propeller wrench to tighten the propeller nut another $\frac{1}{4}$ turn.

MotorGuide Accessories Inquiries

Refer to www.motorguide.com for factory authorized accessories for all MotorGuide trolling motors.

TROUBLESHOOTING

Trolling Motor Performance

Symptom	Possible Cause	Resolution
Loss of power	Weak battery	Refer to Wiring and Battery Information .
	Loose or corroded battery connections	
	Propeller is loose, damaged, or off-balance	Refer to Maintenance .
	Wiring or electrical connection faulty	Wire gauge from the battery to the trolling motor is insufficient. Six-gauge wire is recommended.
	Weeds, fishing line, or debris wrapped around propeller	Remove weeds, fishing line, or debris from propeller.
Excessive noise, vibration	Motor shaft is bent	Refer to Warranty Information .
	Propeller is loose, damaged, or off-balance	Refer to Maintenance .
Motor failure (all speeds)	Weak battery	Refer to Wiring and Battery Information .
	Loose or corroded battery connections	
	Electrical	Check the connector for a loose or damaged connection. Refer to Wiring and Battery Information .
	Fuse on circuit breaker is open	Replace the fuse or reset the circuit breaker only after determining the root cause of the problem.
Motor failure (one or more speeds)	Propeller is loose, damaged, or off-balance	Refer to Maintenance .
	Wiring or electrical connection faulty.	Refer to Warranty Information .

TROUBLESHOOTING

Symptom	Possible Cause	Resolution
Difficulty removing propeller	Bent propeller pin	Hold one blade and lightly tap the opposite blade with a rubber mallet.
		Use a putty knife on both sides of the propeller to apply equal pressure.
	Bent armature shaft	Refer to service center.

OWNER SERVICE ASSISTANCE

Mercury Marine Service Offices

For assistance, call, fax, or write. Please include your daytime telephone number with mail and fax correspondence.

United States		
Telephone	English - (920) 929-5040 Francais - (905) 636-4751	Mercury Marine W6250 W. Pioneer Road P.O. Box 1939 Fond du Lac, WI 54936-1939
Fax	English - (920) 929-5893 Francais - (905) 636-1704	
Website	www.motorguide.com	

Australia, Pacific		
Telephone	(61) (3) 9791-5822	Mercury Marine Australia 132-140 Frankston Road Dandenong, Victoria 3164 Australia
Fax	(61) (3) 9706-7228	

Europe, Middle East, Africa		
Telephone	(32) (87) 32 • 32 • 11	Marine Power - Europe, Inc. Parc Industriel de Petit-Rechain B-4800 Verviers, Belgium
Fax	(32) (87) 31 • 19 • 65	

Mexico, Central America, South America, Caribbean		
Telephone	(954) 744-3500	Mercury Marine 11650 Interchange Circle North Miramar, FL 33025 U.S.A.
Fax	(954) 744-3535	

Brunswick Asia Pacific Group		
Telephone	(65) 65466160	T/A Mercury Marine Singapore Pte Ltd 29 Loyang Way Singapore, 508944
Fax	(65) 65467789	