

FCC and IC Compliance Statement

FCC ID: MVUFP01, MVUFP02

ACMA: N2523 

IC: 6094A-FP01, 6094A-FP02

This device complies with part 15 of the FCC Rules. Operation is subject to the following two conditions:

1. This device may not cause harmful interference.
2. This device must accept any interference received including interference that may cause undesired operation.

This device complies with FCC Rules. Changes or modifications not expressly approved by MotorGuide could void the user's authority to operate the equipment.

Thank You

Thank you for choosing MotorGuide® Wireless Edition. MotorGuide capitalized on many years of experience to provide you with a motor designed to deliver wireless control with complete freedom of movement.

MotorGuide Wireless trolling motors provide simple, fast, and precise wireless boat positioning from anywhere on deck with a low-profile foot-pedal. This exclusive, high-frequency foot-pedal is the easiest to use and master for novice and expert alike.

Through the alliance between MotorGuide and Lowrance®, we have co-developed one of the quietest, most accurate transducer integrated trolling motors ever built. The 200/83 kHz transducer provides an accurate sonar plot and a responsive temperature reading. This combination is sure to improve your fishing, season after season.

Remember to keep your receipt and immediately register your trolling motor. Use the enclosed warranty registration card or complete registration on the internet at www.motorguide.com.

At MotorGuide, we believe there are some things you should Never Stop doing.

NEVER STOP LEARNING, NEVER STOP IMPROVING, AND NEVER, EVER STOP FISHING.

Warranty Message

The product you have purchased comes with a **Limited Warranty** from MotorGuide. The terms of the policy are set forth in the **Warranty Information** section of this manual. The policy statement contains a description of the duration of coverage, **important disclaimers and limitations of damages**, and other related information. Please review this important information.

The description and specifications contained herein were in effect at the time this manual was approved for printing. MotorGuide, whose policy is one of continued improvement, reserves the right to discontinue models at any time, to change specifications, designs, methods, or procedures without notice and without incurring obligation.

MotorGuide, Lowell, Michigan U.S.A.

Litho in U.S.A.

© 2010, Mercury Marine

Cradle Lock is a trademark of Brunswick Corporation.

Mercury, Mercury Marine, and MotorGuide are registered trademarks of Brunswick Corporation. Mercury Product Protection logo is a registered service mark of Brunswick Corporation.

Eagle and Lowrance are registered trademarks of Navico Inc. Garmin is a registered trademark of Garmin Ltd. Humminbird is a registered trademark of Johnson Outdoors Marine Electronics, Inc. Vexilar is a registered trademark of Vexilar, Inc.

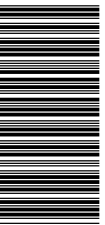

TABLE OF CONTENTS

Section 1 - Warranty Information

MotorGuide Two Year Limited Warranty.....	2
---	---

Section 2 - General Information and Component Identification

Component Identification.....	6	Boater's Responsibilities.....	6
Recording the Serial Number.....	6	Safe Boating Suggestions.....	6

Section 3 - Product Installation, Wiring, and Battery Information

Installing the Mount Base Plate.....	10	Wire and Cable Routing.....	12
Installing the Motor on the Mount Base Plate.....	10	Establishing a Common Ground.....	12
Activating the Wireless Foot Pedal or Handheld Remote.....	11	Electrolysis.....	12
Standard Practice and Procedures.....	12	Battery Connection.....	13
Battery Recommendations.....	12	12 Volt Battery Connection.....	13
Battery Precautions.....	12	24 Volt Battery Connection.....	13

Section 4 - Trolling Motor Operation

Connecting the Sonar Display to Motor.....	16	Foot Pedal Operation.....	18
Stowing and Deploying the Trolling Motor.....	16	Turning the Foot Pedal On-Off.....	18
Stowing the Motor.....	16	Direction Control.....	18
Deploying the Trolling Motor.....	17	Speed Control.....	18
Adjusting the Motor Depth.....	17		

Section 5 - Maintenance and Storage

Trolling Motor Care.....	20	Storage Preparation.....	20
Selecting Replacement Parts.....	20	Battery Inspection.....	21
Inspection and Maintenance Schedule.....	20	Propeller Replacement.....	21
Before Each Use.....	20	Removing the Propeller.....	21
After Each Use.....	20	Installing the Propeller.....	21
Every 100 Hours of Use or Annually (Whichever Occurs First)	20		

Section 6 - Owner Service Assistance

Frequently Asked Questions.....	24	Foot Pedal Battery Replacement.....	26
Troubleshooting.....	24	Handheld Remote Battery Replacement.....	27
Troubleshooting the Foot Pedal and Handheld Remote.....	25	Service Assistance.....	28
Erasing the Receiver's Memory.....	26	Mercury Marine Service Offices.....	28
Reprogramming the Wireless Foot Pedal or Remote.....	26		

Section 1 - Warranty Information

Table of Contents

MotorGuide Two Year Limited Warranty.....	2
---	---

MotorGuide Two Year Limited Warranty

KEEP YOUR ORIGINAL PURCHASE RECEIPT OR BILL OF SALE.

1. For recreational use customers, MotorGuide electric trolling motors are warranted to the original retail purchaser to be free from defects in material or workmanship for a period of two years from the date of purchase.
2. To obtain warranty service, the purchaser should deliver or return the unit (postage prepaid and insured) to any MotorGuide authorized service dealer. DO NOT RETURN TO PLACE OF PURCHASE unless they are an authorized service center. Products returned by mail should be carefully packaged and include a note describing the nature of the problem and/or service requested, customer address, and phone number. A copy of the receipt, bill of sale, registration verification or other proof of purchase is required with the return of the product for warranty consideration. Warranty claims will not be accepted without presentation of purchase receipt for the trolling motor, other verification of registration, or bill of sale for a boat package.
3. MotorGuide, at its discretion, will repair or replace items covered under the terms of this warranty. Neither MotorGuide nor MotorGuide service dealers are responsible for damages to MotorGuide products due to repairs performed by anyone other than an authorized MotorGuide service dealer. Neither MotorGuide nor Attwood is responsible for failure or damage caused by improper installation, set-up, preparation, or previous service or repair errors.
4. For commercial use and government use customers, MotorGuide electric trolling motors are warranted to the original retail purchaser to be free from defects in material or workmanship for one (1) year. Commercial use is defined as any work or employment-related use of the product, or any use of the product which generates income, for any part of the warranty period, even if the product is only occasionally used for such purpose such as rental fleets, guides, fish camps or similar operations. Warranty is not transferable to any subsequent purchaser. The Mercury Product Protection plan is not available to commercial use or government use customers.
5. MotorGuide Composite Shaft Limited Lifetime Warranty. MotorGuide composite shafts are warranted to the original retail purchaser to be free of defects in material or workmanship for the lifetime of the original purchaser. MotorGuide will provide a new composite shaft at no cost for any composite shaft which contains a defect in material or workmanship. The installation costs are the sole responsibility of the purchaser.
6. Warranty coverage is available to customers that purchase from an authorized dealer or retailer that is authorized by MotorGuide Marine to distribute the product in the country in which the sale occurred. Warranty coverage and duration varies by the country in which the owner resides. This Limited Warranty begins on the date the product is first sold to a purchaser or the date on which the product is first put into service, whichever occurs first. MotorGuide accessories are covered by this Limited Warranty for a coverage period of one (1) year from the date of retail sale. The repair or replacement of parts, or the performance of service under this warranty, does not extend the life of this warranty beyond its original expiration date. Promotional warranties are not included in this statement and coverage may vary by promotion. Product either sold or put into service more than six years from date of manufacture is excluded from warranty coverage.
7. This warranty does not apply to normal worn parts, for example, worn cables, adjustments, or product damage due to: 1) neglect, lack of maintenance, accident, abnormal operation or improper installation or service; 2) abuse, such as, bent metal columns, bent armature shafts, broken control cables, etc., accidents, modifications, misuse, excessive wear or damage caused by an owner's failure to provide reasonable and necessary installation or care; 3) use of an accessory or part not manufactured by MotorGuide or Attwood; 4) alteration or removal of parts; 5) opening the lower unit (motor) by anyone other than an authorized MotorGuide service center will void this warranty.
8. We reserve the right to improve the design of any trolling motor without assuming any obligation to modify any trolling motor previously manufactured.
9. All serialized "Service-Repair" trolling motors receive a (1) one year warranty. Non-serialized "Service-Repair" electric trolling motors are NOT warranted. "Service-Repair" motor denotes a trolling motor sold by MotorGuide that may be used, but has been inspected and may have had minor repairs. Original retail purchaser of a "Service-Repair" motor is the first purchaser of the motor after it is denoted as "Service-Repair." "Service-Repair" motors have a blue sticker on the battery cable and box denoting "Manufacturer Certified Service-Repair Motor."
10. This warranty will not apply to: 1) haul-out, launch, towing and storage, transportation charges and/or travel time, telephone or rental charges of any type, inconvenience, or loss of time or income, or other consequential damages; or 2) removal or replacement of boat partitions or material because of boat design for necessary access to the Product; or 3) disconnection and reconnection of hard-wired trolling motors.
11. TERMINATION OF COVERAGE: Warranty coverage may be terminated for repossessed product, or product purchased at auction, from a salvage yard, from a liquidator, from an insurance company, from unauthorized marine dealers or boatbuilders, or other third party entities.
12. ALL INCIDENTAL OR CONSEQUENTIAL DAMAGES ARE EXCLUDED FROM THIS WARRANTY, WARRANTIES OF MERCHANTABILITY AND FITNESS ARE EXCLUDED FROM THIS WARRANTY, IMPLIED WARRANTIES ARE LIMITED TO THE LIFE OF THIS WARRANTY. SOME STATES DO NOT ALLOW LIMITATIONS ON HOW LONG AN IMPLIED WARRANTY LASTS OR THE EXCLUSION OR LIMITATION OF INCIDENTAL OR CONSEQUENTIAL DAMAGES, SO THE ABOVE LIMITATIONS OR EXCLUSIONS MAY NOT APPLY TO YOU. THIS WARRANTY GIVES YOU SPECIFIC LEGAL RIGHTS, AND YOU MAY ALSO HAVE OTHER LEGAL RIGHTS WHICH MAY VARY FROM STATE TO STATE.

For Your Records:

Model Number _____

Serial Number _____

Notes:

Section 2 - General Information and Component Identification

Table of Contents

2

Component Identification.....	6	Boater's Responsibilities.....	6
Recording the Serial Number.....	6	Safe Boating Suggestions.....	6

Component Identification

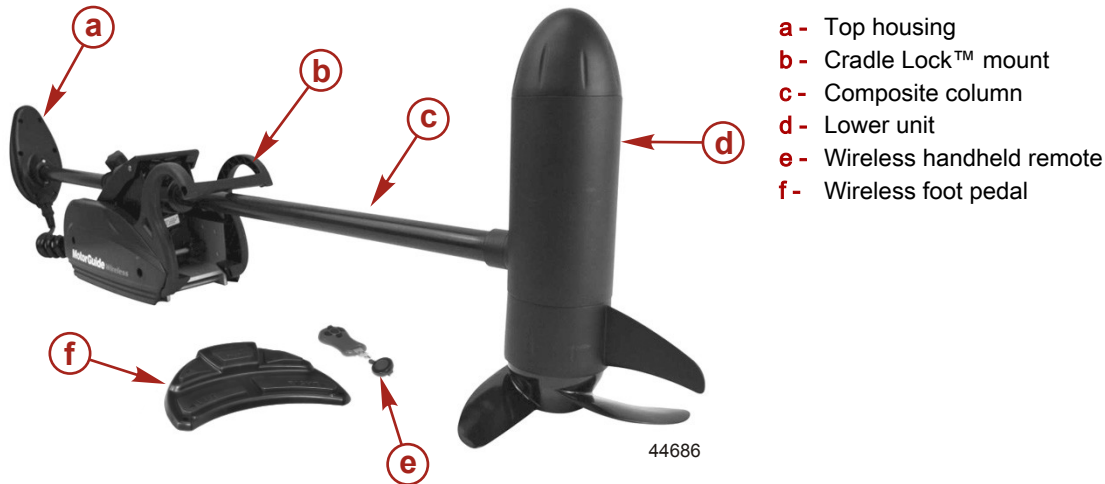

Recording the Serial Number

It is important to record the serial number for future reference. The serial number is located on the motor as shown.

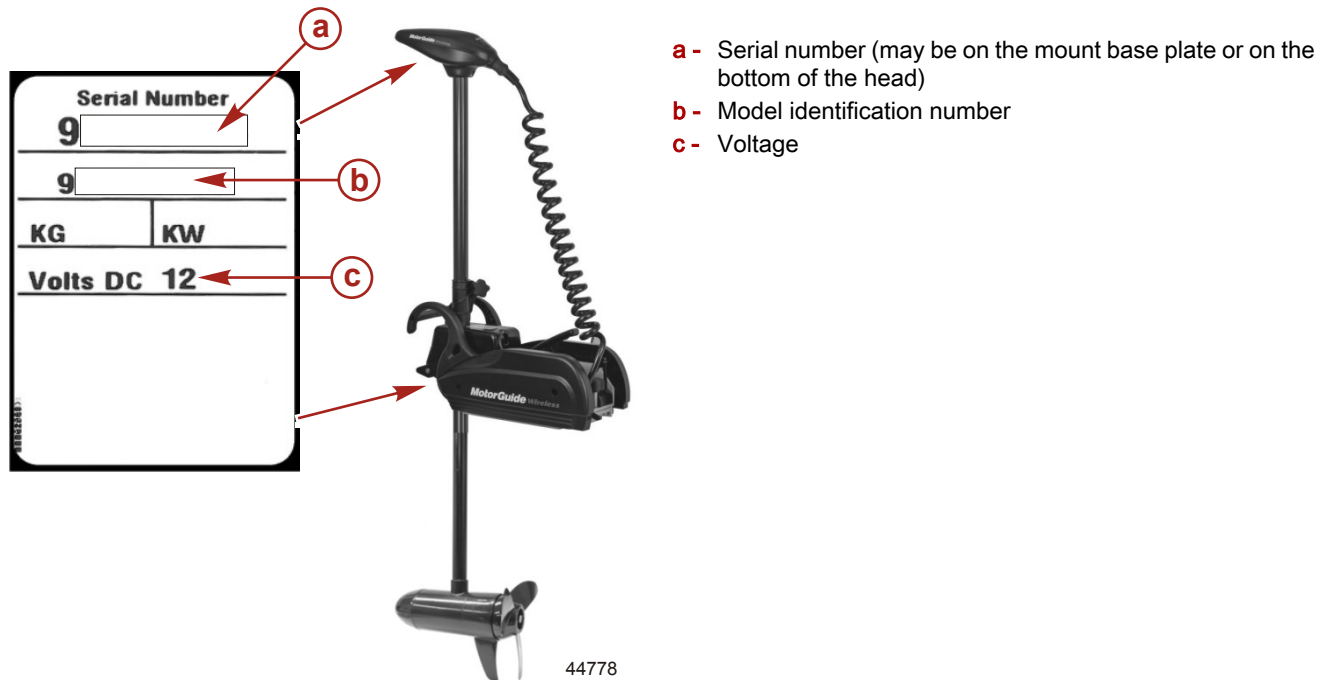

Boater's Responsibilities

The operator (driver) is responsible for the correct and safe operation of the boat and safety of its occupants and general public. It is strongly recommended that each operator (driver) read and understand this entire manual before operating the trolling motor.

Be sure at least one additional person on board is instructed in the basic operation of the trolling motor in case the driver is unable to operate the boat.

Safe Boating Suggestions

In order to safely enjoy the waterways, familiarize yourself with local and other governmental boating regulations and restrictions, and consider the following suggestions.

Use flotation devices. It is the law to have an approved personal flotation device of suitable size for each person aboard and have it readily accessible.

Do not overload your boat. Most boats are rated and certified for maximum load (weight) capacities, refer to your boat capacity plate. If in doubt, contact your dealer or the boat's manufacturer.

Perform safety checks and required maintenance. Follow a regular schedule and ensure all repairs are made properly.

Never be under the influence of alcohol or drugs while boating (it is the law). Alcohol or drug use impairs your judgment and greatly reduces your ability to react quickly.

Passenger boarding. Stop the trolling motor whenever passengers are boarding or unloading.

Be alert. The operator of the boat is responsible by law to maintain a proper lookout by sight and hearing. The operator must have an unobstructed view particularly to the front. No passengers, load, or fishing seats should block the operators view when operating the boat.

Underwater hazards. Reduce speed and proceed with caution whenever navigating in shallow water.

Tripping hazards. To avoid a trip hazard, route all cables and wiring neatly and out of the way.

Report accidents. Boat operators are required by law to file a Boating Accident Report with their state boating law enforcement agency when their boat is involved in certain boating accidents. A boating accident must be reported if 1) there is loss of life or probable loss of life, 2) there is personal injury requiring medical treatment beyond first aid, 3) there is damage to boats or other property where the damage value exceeds \$500.00 or 4) there is complete loss of the boat. Seek further assistance from local law enforcement.

Notes:

Section 3 - Product Installation, Wiring, and Battery Information

Table of Contents

Installing the Mount Base Plate.....	10	Wire and Cable Routing.....	12
Installing the Motor on the Mount Base Plate.....	10	Establishing a Common Ground.....	12
Activating the Wireless Foot Pedal or Handheld Remote.....	11	Electrolysis	12
Standard Practice and Procedures.....	12	Battery Connection.....	13
Battery Recommendations.....	12	12 Volt Battery Connection	13
Battery Precautions.....	12	24 Volt Battery Connection	13

3

Installing the Mount Base Plate

IMPORTANT: Choose an area on the deck with 6.4 cm (2.5 in.) of clearance from the bow of the boat for all motor positions including run and stow positions.

1. Select an appropriate area on the deck of the boat close to the centerline to install the mount. Ensure that the forward mounting screws will not penetrate the hull.
2. Place the mount base plate on the surface of the boat deck with the flange hook facing outward on the bow of the boat. Use the mount plate as a template to mark the location of the mount holes.

NOTE: When installing the mount base plate, ensure that the head of the motor does not protrude beyond the beam of the boat when installed and in the stow position.

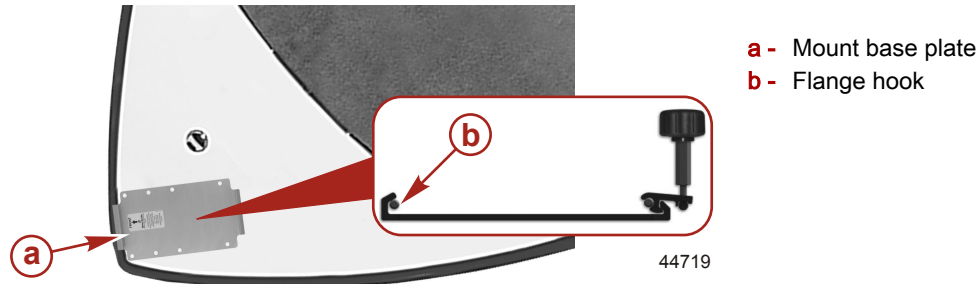

3. Drill the mounting holes with a 8 mm (5/16 in.) drill bit. Remove any debris.
IMPORTANT: Use a larger drill bit and countersink the holes to prevent cracking in the deck of fiberglass boats.
4. Align the mount base plate to the holes in the deck. Install the four stainless steel mounting bolts through the mounting holes. Tighten all the mounting bolts securely with a Phillips screwdriver.

Installing the Motor on the Mount Base Plate

1. Retrieve the motor from the packaging and lay it on a flat surface.
2. Loosen the mount lock knob, located at the back of the mount housing.

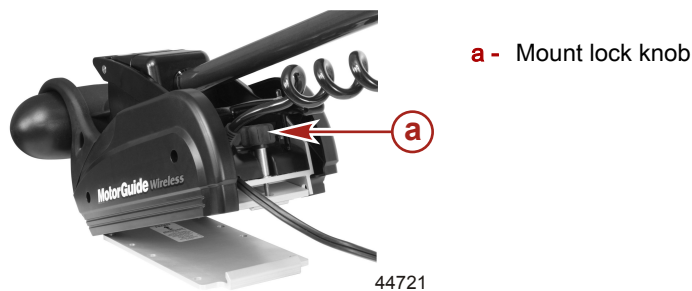

3. At a 10° angle, install the motor and mount to the mount base plate. The mount pivot pin fits into the large flange hook on the mount base plate.

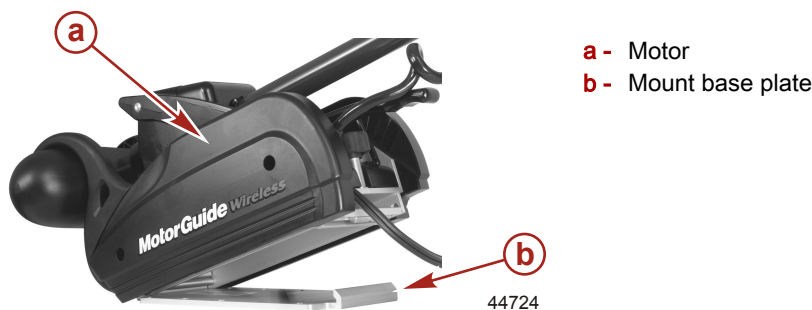

- Secure the back of the mount by turning the mount lock knob to engage the cam lock into the base plate lip.

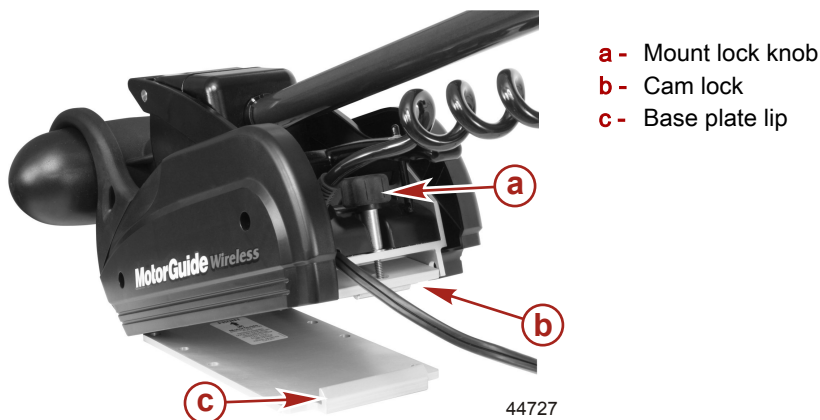

- Deploy the motor. Refer to **Section 4 - Adjusting the Motor Depth** for depth collar adjustment instructions.
- Ensure that the motor is properly secured to the mount base plate before operation.

Activating the Wireless Foot Pedal or Handheld Remote

Each foot pedal and handheld remote has a unique serial number. Program the trolling motor receiver with the serial number of each controller used. The receiver can store up to four serial numbers. This ensures that the trolling motor will only respond to commands from designated controllers. For erasing and reprogramming information, refer to **Section 6 - Erasing the Receiver's Memory** and **Section 6 - Reprogramming the Wireless Foot Pedal or Remote**.



Foot pedal

- a - "LEFT" button
- b - "-" button - slower
- c - "ON-OFF" button
- d - "+" button - faster
- e - "RIGHT" button

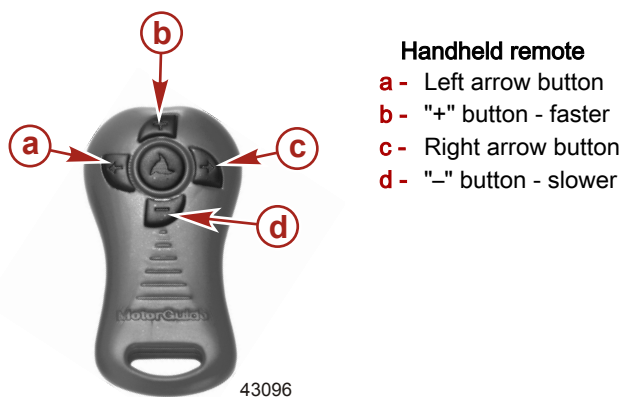

Handheld remote

- a - Left arrow button
- b - "+" button - faster
- c - Right arrow button
- d - "-" button - slower

NOTE: This activation procedure applies to the foot pedal and handheld remote.

IMPORTANT: To activate multiple foot pedals or remotes, the motor must be unplugged from the power source and then plugged back into the power source between activating each control device.

- Plug in the battery cable to a power source. In less than ten seconds, press and hold the (+) and (-) buttons on the controller simultaneously.
- Listen for a long beep indicating the receiver has stored the electronic serial number.

Standard Practice and Procedures

IMPORTANT: Unplug the trolling motor after each use and when charging the battery.

- Do not use the main engine battery to power the trolling motor.
- Route the trolling motor wires on the opposite side of the boat from other boat wiring.

Battery Recommendations

- Use a 12 volt, deep cycle marine battery. Refer to **Battery Connection**.
- Install a 50 amp manual reset circuit breaker in line with the trolling motor positive leads within 180 cm (72 in.) of the batteries.
- Use 13 mm (6 gauge) battery cables if extending the existing wire 3 m (10 ft) beyond the standard battery cable supplied with the product.

Recommended MotorGuide Accessory Description	Part Number
6 gauge battery cable and terminals with 50 amp manual reset circuit breaker	MM309922T
50 amp manual reset circuit breaker	MM5870

Battery Precautions

WARNING

An operating or charging battery produces gas that can ignite and explode, spraying out sulfuric acid, which can cause severe burns. Ventilate the area around the battery and wear protective equipment when handling or servicing batteries.

When charging batteries, an explosive gas mixture forms in each cell. Part of this gas escapes through holes in the vent plugs and may form an explosive atmosphere around the battery if ventilation is poor. This explosive gas may remain in or around the battery for several hours after it has been charged. Sparks or flames can ignite this gas and cause an internal explosion, which may shatter the battery.

The following precautions should be observed to prevent an explosion:

1. Do not smoke near batteries being charged or which have been charged very recently.
2. Do not break live circuits at terminals of batteries, because a spark usually occurs at the point where a live circuit is broken. Always be careful when connecting or disconnecting cable clamps on chargers. Poor connections are a common cause of electrical arcs which cause explosions.
3. Do not reverse polarity of battery terminal to cable connections.

Wire and Cable Routing

- Route the trolling motor wires on the opposite side of the boat from other boat wiring.
- Accessories should be connected directly to the main engine battery.

Establishing a Common Ground

A common ground (–) connection increases sonar sensitivity, improves sonar display, and avoids the ground circuit as a possible source of corrosion or electrolysis. Plug in all main engine accessories and the trolling motor to the same negative ground (–) terminal to establish a common ground.

Electrolysis

Using the main engine battery as a power source for the trolling motor may cause electrolysis on metallic parts. If the motor and battery wiring are installed correctly and electrolysis issues continue, separate the trolling motor from any other boat electronics. Using the main engine battery as a power source for the trolling motor is not recommended. Refer to **Battery Connection** for correct installation.

Battery Connection

⚠ CAUTION

Disconnecting or connecting the battery cables in the incorrect order can cause injury from electrical shock or can damage the electrical system. Always disconnect the negative (-) battery cable first and connect it last.

12 Volt Battery Connection

1. Install a 50 amp manual reset circuit breaker in line with the trolling motor power cable positive (+) lead and the battery positive (+) terminal.
2. Connect the black trolling motor power cable negative lead to the engine battery negative (-) terminal.
3. Connect a jumper cable (common ground bond) from the trolling motor battery negative terminal to the engine battery negative terminal.

NOTE: Vessels with multiple batteries must have a common ground bonding circuit. Not establishing a common ground between the vessel batteries may cause severe corrosion, electrolysis, or electrical shock.

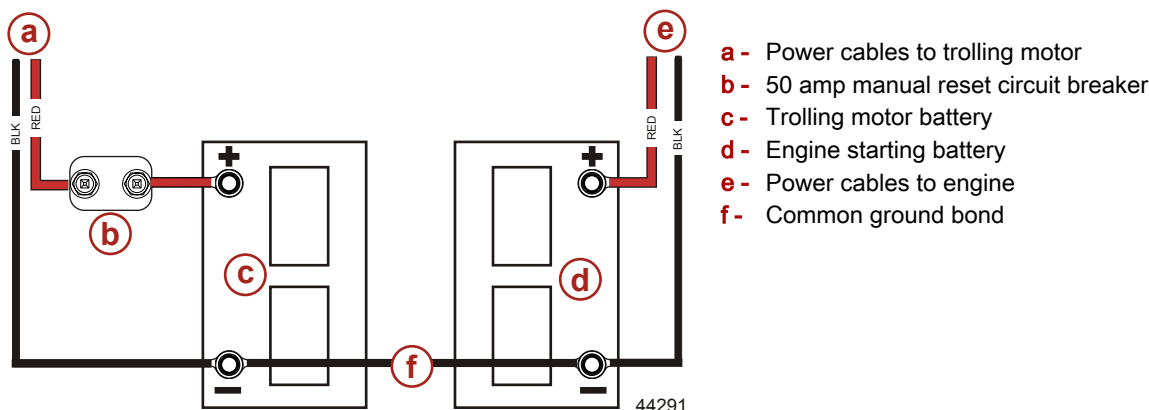

24 Volt Battery Connection

1. Install a 50 amp manual reset circuit breaker in line with the trolling motor power cable positive (+) lead and battery "c" positive (+) terminal.
2. Connect a jumper wire (reference grey) between the negative (-) terminal on battery "c" to the positive (+) terminal on battery "d."
3. Connect the trolling motor negative (-) lead to the negative (-) terminal on battery "d."
4. Connect a jumper cable (common ground bond) from the trolling motor battery "d" negative (-) terminal to the engine battery negative terminal.

NOTE: Vessels with multiple batteries must have a common ground bonding circuit. Not establishing a common ground between the vessel batteries may cause severe corrosion, electrolysis, or electrical shock.

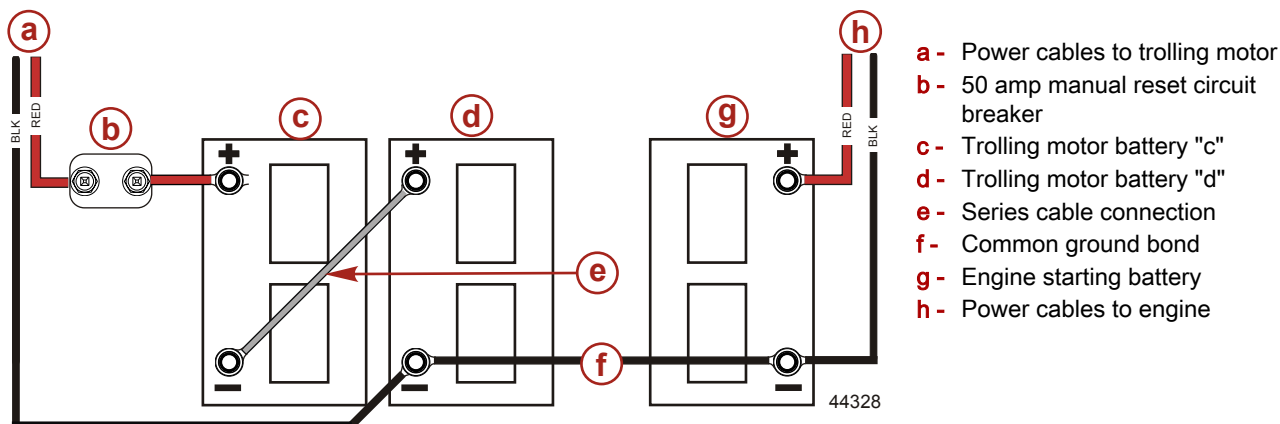

Notes:

Section 4 - Trolling Motor Operation

Table of Contents

Connecting the Sonar Display to Motor.....	16	Foot Pedal Operation.....	18
Stowing and Deploying the Trolling Motor.....	16	Turning the Foot Pedal On-Off	18
Stowing the Motor	16	Direction Control	18
Deploying the Trolling Motor	17	Speed Control	18
Adjusting the Motor Depth.....	17		



Connecting the Sonar Display to Motor

NOTE: This sonar display connection procedure applies to the Wireless Series motor that offers built-in 200/83 kHz sonar transducers compatible with Eagle®, Garmin®, Humminbird®, Lowrance®, and Vexilar® brand sonar displays. Wireless sonar models connect with Lowrance 6 pin sonar units. For compatibility with other sonar units, refer to www.motorguide.com.

Match the cable connector to the sonar port on the back of the sonar display. Power up the unit to ensure that the sonar cable is connected securely.

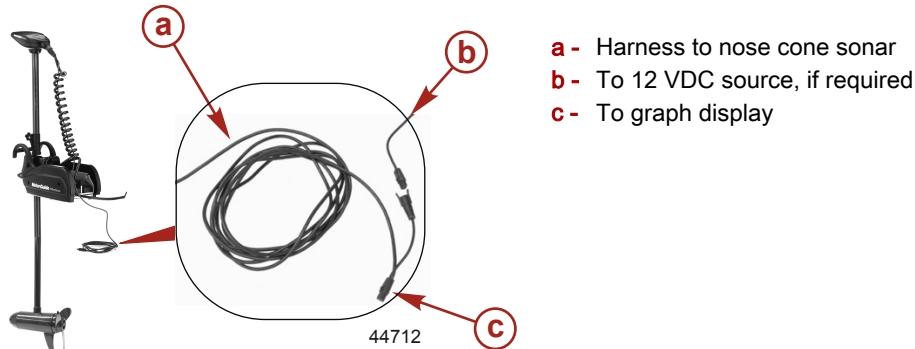

Stowing and Deploying the Trolling Motor

⚠ WARNING

Rotating propellers can cause serious injury or death. Never start or operate the motor out of water.

⚠ CAUTION

Moving parts, such as hinges and pivot points, can cause serious injury. Keep away from moving parts when stowing, deploying, or tilting the motor.

Stowing the Motor

1. Firmly grasp the column with one hand and then pull up on the release handle with the other hand.



2. Raise the motor out of the water and rotate the shaft so that the lower unit is aligned with the mount cradle. Once the motor is in the stow position, push down on the column to lock the lower unit into the cradle and to lock the release handle.

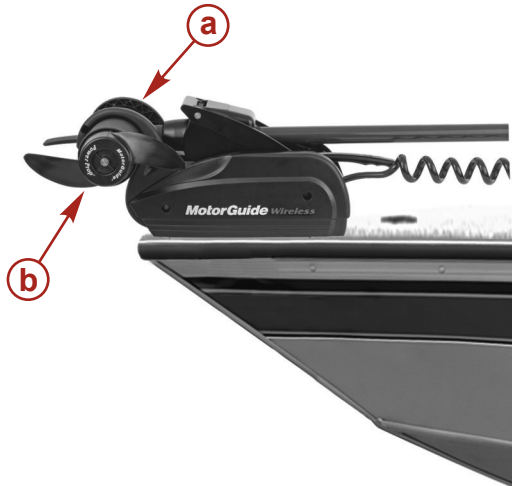

- a - Mount cradle
- b - Lower unit

44733

Deploying the Trolling Motor

1. Firmly grasp the column with one hand and then pull up on the release handle with the other hand.

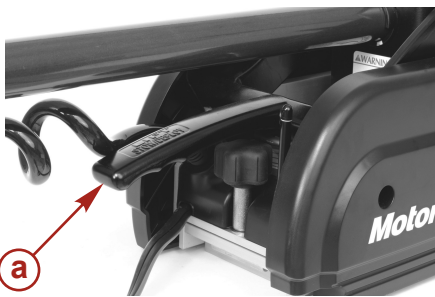

- a - Release handle

44734

2. Raise the motor out of the stow position and lower the trolling motor until the depth collar rests on top of the steering housing collar. Rotate and lock the depth collar into the steering housing collar.

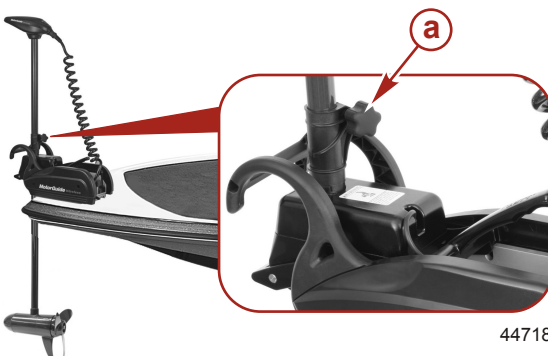

- a - Depth collar

44718

Adjusting the Motor Depth

⚠ CAUTION

Avoid possible serious injury from dropping the motor when adjusting the motor depth. Firmly grasp the motor shaft with one hand when raising or lowering the motor.

Adjust the depth of the motor to improve the trolling motor performance in various water depths.

Section 4 - Trolling Motor Operation

IMPORTANT: When adjusting the motor depth, ensure the lower unit is fully submerged a minimum of 30 cm (12 in.) to avoid propeller cavitation.

1. Firmly grasp the column with one hand while loosening the depth collar knob so that the column moves freely.

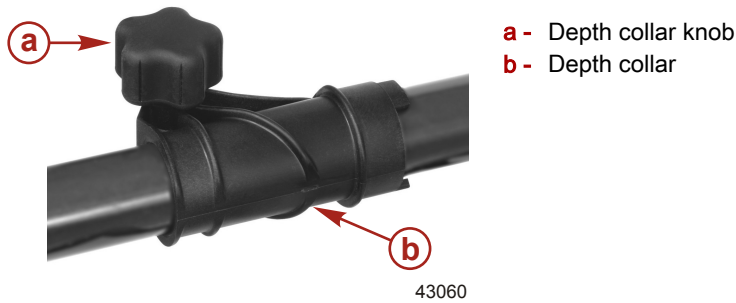

2. Raise or lower the column to the desired depth. Tighten the depth collar knob to secure the column.

Foot Pedal Operation

⚠ WARNING

Rotating propellers can cause serious injury or death. Never start or operate the motor out of water.

To operate the foot pedal, activate the foot pedal electronic ID. Refer to **Section 3 - Activating the Wireless Foot Pedal or Handheld Remote**.



Wireless foot pedal

- a - "LEFT" button
- b - "-" button - slower
- c - "ON-OFF" button
- d - "+" button - faster
- e - "RIGHT" button

Turning the Foot Pedal On-Off

Press the center "ON-OFF" button. A short beep indicates the foot pedal is turned on; a long beep indicates the foot pedal is turned off.

Direction Control

Press the "LEFT" or "RIGHT" buttons on the foot pedal to steer the boat. Each button press steers the motor left or right an additional 9°. Depressing the button constantly will rapidly steer the motor in the direction selected.

Speed Control

⚠ WARNING

Avoid possible serious injury from unexpected acceleration and boat movement when activating the trolling motor. When using the foot-pedal, the motor will start up at the last selected speed and course settings. Before pressing the foot-pedal, hold on to a seat or handhold, and advise passengers to do the same.

Press the "+" and "-" buttons on the foot pedal to control motor speed. A short beep will sound each time either button is pushed. Depressing the "+" or "-" buttons constantly will rapidly increase or decrease the speed of the motor. Upon reaching the minimum or maximum speed, the foot pedal will no longer beep.

Section 5 - Maintenance and Storage

Table of Contents

Trolling Motor Care.....	20	Storage Preparation.....	20
Selecting Replacement Parts	20	Battery Inspection.....	21
Inspection and Maintenance Schedule.....	20	Propeller Replacement.....	21
Before Each Use	20	Removing the Propeller	21
After Each Use	20	Installing the Propeller	21
Every 100 Hours of Use or Annually (Whichever Occurs First)	20		

Trolling Motor Care

To keep your trolling motor in the best operating condition and retain its dependability, your trolling motor must receive periodic inspections and maintenance. Keep it maintained properly to ensure the safety of you and your passengers.

⚠ WARNING

Neglecting to inspect, maintain, or repair your trolling motor can result in product damage or serious injury or death. Do not perform maintenance or service on your trolling motor if you are not familiar with the correct service and safety procedures.

Record all maintenance performed and save maintenance work orders and receipts.

Selecting Replacement Parts

Use only original MotorGuide replacement parts.

Inspection and Maintenance Schedule

Before Each Use

- Inspect for loose or corroded wiring connections.
- Check the tightness of the battery lead connections.
- Check the tightness of the propeller nut.
- Check the propeller blades for damage.

After Each Use

- Disconnect the battery cables from the power source or unplug the motor from the boat.
- After each use, check each side of the propeller and propeller shaft for debris such as weeds and fishing line. Remove all debris.
- Check the tightness of the propeller nut.
- Rinse the trolling motor with clean water to remove dirt and dust that may scratch the surface.

Every 100 Hours of Use or Annually (Whichever Occurs First)

- Apply 2-4-C with Teflon to the depth collar knob screw threads and the mount lock knob screw threads.
IMPORTANT: Never use an aerosol lubricant to grease or oil any part of the unit. Many aerosol lubricants contain harmful propellants that can cause damage to various parts of the trolling motor.



- a - Depth collar knob screw threads
- b - Mount lock knob screw threads

Tube Ref No.	Description	Where Used	Part No.
 95	2-4-C with Teflon	Depth collar knob screw threads and the mount lock knob screw threads	92-802859A 1

- Check the tightness of bolts, nuts, and other fasteners.
- Inspect the battery. Refer to **Battery Inspection**.

Storage Preparation

The major consideration in preparing your trolling motor for storage is to protect it from corrosion and damage caused by freezing of trapped water.

Refer to the **Maintenance—Inspection and Maintenance Schedule** section and complete the appropriate care instructions to prepare your trolling motor for storage. Store the trolling motor in a dry location where it will not be affected by temperatures below -29 °C (-20 °F).

IMPORTANT: Trolling motors stored in temperatures below 0 °C (32 °F) should be operated slowly for a minimum of 15 minutes before going above 30% operation.

Battery Inspection

The battery should be inspected at periodic intervals to ensure proper trolling motor operation.

IMPORTANT: Read the safety and maintenance instructions which accompany your battery.

1. Ensure that the battery is secured to the vessel.
2. Ensure that the battery cable terminals are clean, tight, and correctly installed. For installation instructions, refer to **Section 3 - Battery Connection**.
3. Ensure that the battery is equipped with a battery box to prevent accidental shorting of the battery terminals.

Propeller Replacement

⚠ WARNING

Performing service or maintenance without first disconnecting the battery can cause product damage, personal injury, or death due to fire, explosion, electrical shock, or unexpected motor starting. Always disconnect the battery cables from the battery before maintaining, servicing, installing, or removing motor components.

Removing the Propeller

1. Disconnect the power cables from the battery.
2. While holding the propeller blade with one hand, use a propeller wrench to remove the propeller nut.
IMPORTANT: Remove the propeller nut with a propeller wrench. Using another tool may damage the propeller nut or shaft. If the propeller cannot be removed easily, use a rubber mallet to lightly tap the backside of the opposite blade. If the propeller cannot be removed, have the propeller removed by an authorized dealer.

NOTE: If the propeller pin is bent, replace the propeller pin.



a - Propeller wrench

Recommended MotorGuide Accessory Description	Part Number
MotorGuide Prop Wrench Kit	MGA050B6

Installing the Propeller

1. Rotate the motor shaft to insert the propeller pin horizontally.

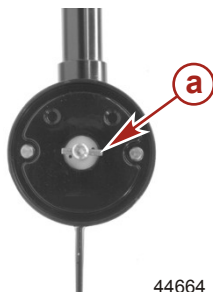

a - Propeller pin

Section 5 - Maintenance and Storage

2. Install the propeller onto the motor shaft by engaging the propeller onto the propeller pin.



3. Install the propeller nut. Tighten securely.

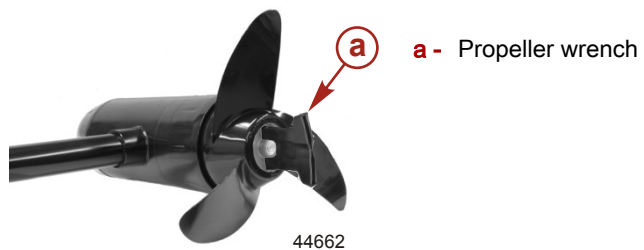

4. Use the propeller wrench to tighten the propeller nut another $\frac{1}{4}$ turn.

Section 6 - Owner Service Assistance

Table of Contents

Frequently Asked Questions.....	24	Foot Pedal Battery Replacement	26
Troubleshooting.....	24	Handheld Remote Battery Replacement	27
Troubleshooting the Foot Pedal and Handheld Remote.....	25	Service Assistance.....	28
Erasing the Receiver's Memory	26	Mercury Marine Service Offices.....	28
Reprogramming the Wireless Foot Pedal or Remote ...	26		

Frequently Asked Questions

- **Why does the receiver beep when I press a button on the foot pedal, but nothing happens?**

The foot pedal's electronic serial number is not programmed. Refer to **Section 3 - Activating the Wireless Foot Pedal or Handheld Remote**.

- **Why does the electronic ID number not work after I activate it?**

The receiver's memory may be full. Refer to **Erasing the Receiver's Memory**.

- **The motor hit an object underwater and will not run. When I pressed the test button on the battery indicator, why did all of the lights illuminate at once?**

When all lights on the battery indicator illuminate at once this means the steering or trolling motor have overloaded. Allow the motor to cool down and then power cycle the motor by unplugging the motor from the battery and then plugging it back in. If the system does not return to normal after cooling or power cycling, contact a service center.

- **Why did the foot pedal stop working?**

Check the battery in the foot pedal and replace if necessary. Refer to **Troubleshooting the Foot Pedal and Handheld Remote**.

- **After running the motor, I turned it off and then turned it back. Why did the motor not resume at the previous speed?**

The motor temporarily lost battery connection. Check all of the battery connections.

Troubleshooting

NOTE: For service information, contact any certified MotorGuide service center. For a full listing of MotorGuide service centers, go to www.motorguide.com or contact any Mercury Marine service office.

Symptom	Possible Cause	Resolution
Trolling motor does not respond to wireless commands	Weak 12 volt trolling motor battery	Check 12 volt battery charge indicator on trolling motor. Recharge or replace battery as required.
	Weak handheld remote battery or weak foot pedal battery	Test the handheld remote battery and the foot pedal battery for proper voltage. Fully charged batteries are 3.2 volts. Replace the batteries if voltage is less than 2.8 volts.
Loss of power	Weak 12 volt trolling motor battery	Check 12 volt battery charge indicator on trolling motor. Recharge or replace battery as required.
	Loose or corroded battery connections	Inspect battery connections for cleanliness and tightness.
	Propeller is loose, damaged, or off-balance	Refer to Section 5 - Propeller Replacement .
	Wiring or electrical connection faulty	Wire gauge from the battery to the trolling motor is insufficient. Six gauge wire is recommended.
	Magnets cracked or chipped	The motor will whine or grind. Contact a Service Center .
Excessive noise or vibration	Water intrusion in the lower unit	Contact a Service Center .
	Propeller is loose, damaged, or off-balance	Refer to Section 5 - Propeller Replacement .
	Damaged bearings or bushings	Contact a Service Center .
	Magnets interfering with armature	Turn off the power and manually rotate the propeller. If the propeller does not rotate freely with a slight magnetic drag, contact a Service Center .
	Magnets cracked or chipped	The motor will whine or grind. Contact a Service Center .

Symptom	Possible Cause	Resolution
Motor failure (motor runs at partial speed)	Loose electrical connections	Connections in the top housing may be loose or damaged. Contact a Service Center .
	Thermal protection is overloaded	Temperature exceeds specification. Contact a Service Center .
	Propeller is loose, damaged, or off-balance	Refer to Section 5 - Propeller Replacement .
Motor failure (motor does not run)	Weak 12 volt trolling motor battery	Check 12 volt battery charge indicator on trolling motor. Recharge or replace battery as required.
	Loose or corroded battery connections	Inspect battery connections for cleanliness and tightness.
	Wiring or electrical connection faulty	Wire gauge from the battery to the trolling motor is insufficient. Six gauge wire is recommended.
	Loose electrical connections	Inspect connections for cleanliness and tightness.
	Thermal protection is overloaded	Temperature exceeds specification. Contact a Service Center .
	Fuse on circuit breaker is open	Replace the fuse or reset the circuit breaker only after determining the root cause of the problem.
	Magnets interfering with armature	Turn off the power and manually rotate the propeller. If the propeller does not rotate freely with a slight magnetic drag, contact a Service Center .
	Boat wiring faulty	Contact a Service Center .
Inaccurate temperature reading	Lower unit not fully submerged	Adjust the depth of the motor. Ensure the lower unit is fully submerged. Refer to Section 4 - Adjusting the Motor Depth .
	Damaged nose cone	Contact a Service Center .
	Damaged sonar cable	Contact a Service Center .
Mount is hard to latch to the mount base plate	Cam lock is not secure	Ensure the cam lock is loose and disengaged from the mount base plate.
	Pivot pin is not engaged	Ensure the pivot pin on the mount is fully engaged in the large flange hook.
	Mount base plate is not level	Ensure that the mount base plate is mounted evenly on the boat deck. If necessary, install shim washers (not included) and then tighten the screws. Refer to Section 3 - Product Installation for help.
Difficulty removing propeller	Bent propeller pin	Hold one blade and lightly tap the opposite blade with a rubber mallet.
		Use a putty knife on both sides of the propeller to apply equal pressure.
	Bent armature shaft	Contact a Service Center .

Troubleshooting the Foot Pedal and Handheld Remote



Foot pedal

- a - "LEFT" button
- b - "-" button - slower
- c - "ON-OFF" button
- d - "+" button - faster
- e - "RIGHT" button

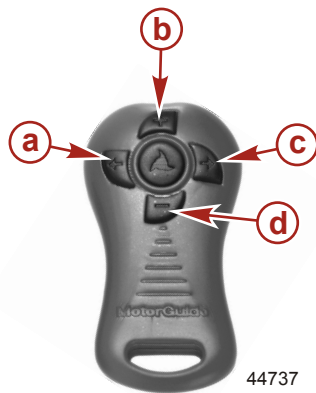

Handheld remote

- a** - Left arrow button
- b** - "+" button - faster
- c** - Right arrow button
- d** - "-" button - slower

Erasing the Receiver's Memory

Erasing the receiver's memory will erase all electronic ID numbers that are stored in the receiver's memory.

1. Plug in the battery cable to a power source. In less than ten seconds, press the left arrow, right arrow, "+" and "-" buttons on the remote simultaneously. For foot pedals, press the "LEFT," "RIGHT," "+," and "-" buttons simultaneously.
2. Listen for a long beep indicating the receiver has erased all stored electronic ID numbers.

NOTE: If all four buttons on the remote are not pressed simultaneously within ten seconds, or a long beep is not heard, unplug the battery cables from the power source and then refer to **Section 3 - Activating the Wireless Foot Pedal or Handheld Remote**.

Reprogramming the Wireless Foot Pedal or Remote

NOTE: This activation procedure applies to the foot pedal and remote.

IMPORTANT: To activate multiple foot pedals or remotes, the motor must be unplugged from the power source and then plugged back into the power source between activating each control device.

1. Unplug the battery cables from the power source. Wait 30 seconds and then plug the motor into the power source.
2. In less than ten seconds, press and hold the "+" and "-" buttons on either the handheld remote or the foot pedal controller simultaneously.

Foot Pedal Battery Replacement

Battery required: 3V lithium, CR2032

1. Remove the five screws on the battery cover plate. Remove the battery cover plate.

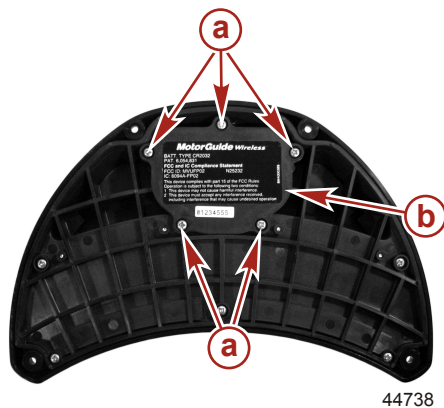

- a** - Battery cover plate screws
- b** - Battery cover plate

- Using a pencil or a similar tool, push out the old battery.

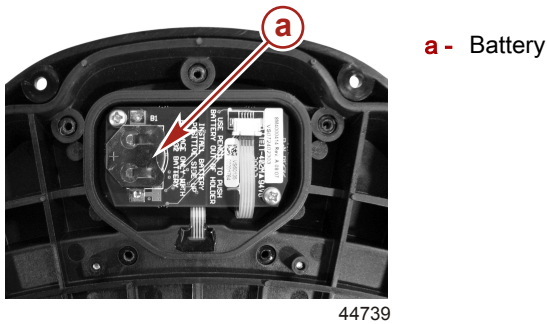

- Insert the new battery with the positive side facing up.
- Ensure the O-ring is positioned correctly on the inside of the battery cover.

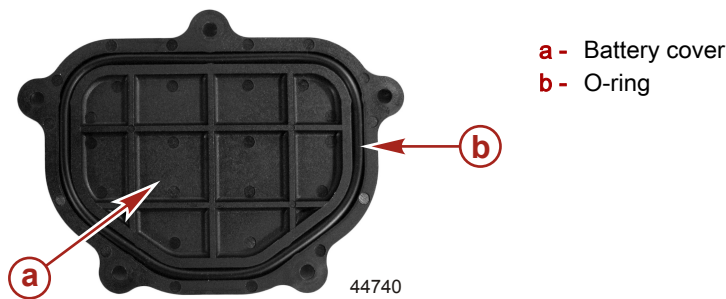

- Replace the battery cover plate and install the five screws. Tighten the screws securely.

Handheld Remote Battery Replacement

Battery required: 3V lithium, CR2032

- Remove the four screws from the back of the handheld remote. Remove the back cover.

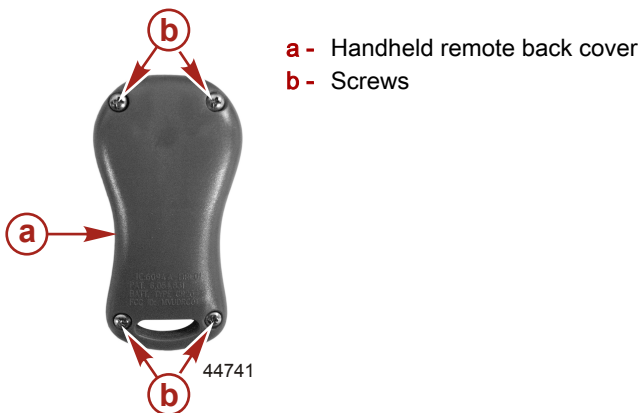

- Remove the green circuit board. Turn the circuit board over. Using a pencil or similar tool, push out the old battery.

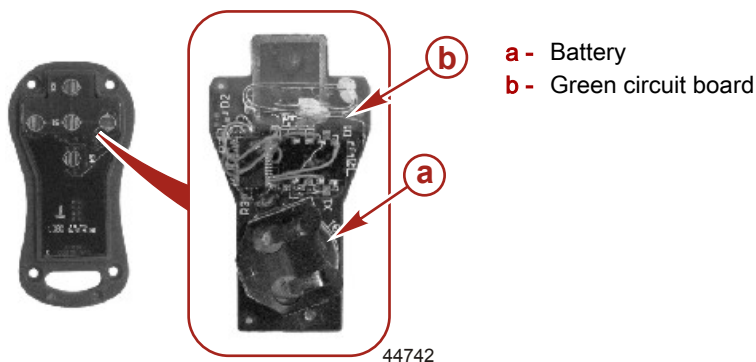

- Insert the new battery with the positive side facing up.

Section 6 - Owner Service Assistance

4. Install the green circuit board in the remote control housing.
5. Replace the handheld remote back plate and install the four screws. Tighten the screws securely.

Service Assistance

Your satisfaction with your product is very important to us. If you have a problem or question about your motor, contact your dealer or any certified MotorGuide Service Center. For more service assistance information, refer to **Section 1 - Warranty Information**.

The following information will be needed by the service office:

- Your name and address
- Daytime telephone number
- Model and serial number of your trolling motor
- Proof of purchase or registration verification
- Nature of problem

Mercury Marine Service Offices

For assistance, call, fax, or write. Please include your daytime telephone number with mail and fax correspondence.

United States		
Telephone	English - (920) 929-5040	Mercury Marine W6250 W. Pioneer Road Fond du Lac, WI 54936-1939
	Francais - (905) 636-4751	
Fax	English - (920) 929-5893	
	Francais - (905) 636-1704	
Website	www.motorguide.com	
Australia, Pacific		
Telephone	(61) (3) 9791-5822	Mercury Marine Australia 132-140 Frankston Road Dandenong, Victoria 3164 Australia
Fax	(61) (3) 9706-7228	
Europe, Middle East, Africa		
Telephone	(32) (87) 32 • 32 • 11	Marine Power - Europe, Inc. Parc Industriel de Petit-Rechain B-4800 Verviers, Belgium
Fax	(32) (87) 31 • 19 • 65	
Mexico, Central America, South America, Caribbean		
Telephone	(954) 744-3500	Mercury Marine 11650 Interchange Circle North Miramar, FL 33025 U.S.A.
Fax	(954) 744-3535	
Brunswick Asia Pacific Group		
Telephone	(65) 65466160	T/A Mercury Marine Singapore Pte Ltd 29 Loyang Drive Singapore, 508944
Fax	(65) 65467789	