

Thank You

for your purchase of one of the finest outboards available. You have made a sound investment in boating pleasure. Your outboard has been manufactured by Mercury Marine, a world leader in marine technology and outboard manufacturing since 1939. These years of experience have been committed to the goal of producing the finest quality products. This led to Mercury Marine's reputation for strict quality control, excellence, durability, lasting performance, and being the best at providing after the sale support.

Please read this manual carefully before operating your outboard. This manual has been prepared to assist you in the operation, safe use, and care of your outboard.

All of us at Mercury Marine took pride in building your outboard and wish you many years of happy and safe boating.

Again, thank you for your confidence in Mercury Marine.

EPA Emissions Regulations

Outboards sold by Mercury Marine in the United States are certified to the United States Environmental Protection Agency as conforming to the requirements of the regulations for the control of air pollution from new outboard motors. This certification is contingent on certain adjustments being set to factory standards. For this reason, the factory procedure for servicing the product must be strictly followed and, wherever practicable, returned to the original intent of the design. **Maintenance, replacement, or repair of the emission control devices and systems may be performed by any marine engine repair establishment or individual.**

Engines are labeled with an Emission Control Information decal as permanent evidence of EPA certification.

WARNING

The engine exhaust from this product contains chemicals known to the state of California to cause cancer, birth defects or other reproductive harm.

Warranty Message

The product you have purchased comes with a **limited warranty** from Mercury Marine, the terms of the warranty are set forth in the **Warranty Information** section of this manual. The warranty statement contains a description of what is covered, what is not covered, the duration of coverage, how to best obtain warranty coverage, **important disclaimers and limitations of damages**, and other related information. Please review this important information.

The description and specifications contained herein were in effect at the time this manual was approved for printing. Mercury Marine, whose policy is one of continued improvement, reserves the right to discontinue models at any time, to change specifications, designs, methods, or procedures without notice and without incurring obligation.

Mercury Marine, Fond du Lac, Wisconsin U.S.A.

Litho in U.S.A.

© 2011, Mercury Marine

Mercury, Mercury Marine, MerCruiser, Mercury MerCruiser, Mercury Racing, Mercury Precision Parts, Mercury Propellers, Mariner, Quicksilver, #1 On The Water, Alpha, Bravo, Pro Max, OptiMax, Sport-Jet, K-Planes, MerCathode, RideGuide, SmartCraft, Zero Effort, M with Waves logo, Mercury with Waves logo, and SmartCraft logo are all registered trademarks of Brunswick Corporation. Mercury Product Protection logo is a registered service mark of Brunswick Corporation.

Mercury Premier Service

Mercury evaluates the service performance of its dealers and assigns its highest rating of "Mercury Premier" to those demonstrating an exceptional commitment to service.

Earning a Mercury Premier Service rating means a dealer:

- Achieves a high 12 month service CSI (Customer Satisfaction Index) score for warranty service.
- Possesses all necessary service tools, test equipment, manuals, and parts books.
- Employs at least one Certified or Master technician.

- Provides timely service for all Mercury Marine customers.
- Offers extended service hours and mobile service, when appropriate.
- Uses, displays, and stocks adequate inventory of genuine Mercury Precision Parts.
- Offers a clean, neat shop with well organized tools and service literature.

Declaration of Conformity Four Stroke - For Recreational Craft Propulsion Engines with the Requirements of Directive 94/25/EC as amended by 2003/44/EC

Name of engine manufacturer: Mercury Marine			
Address: W6250 Pioneer Road P.O. Box 1939			
Town: Fond du Lac, WI	Post Code: 54936-1939	Country: USA	

Name of Authorized Representative: Brunswick Marine in EMEA Inc.			
Address: Parc Industriel de Petit-Rechain			
Town: Verviers	Post Code: 4800	Country: Belgium	

Name of Notified Body for exhaust emission assessment: Det Norske Veritas AS			
Address: Veritasveien 1			
Town: Hovik	Post Code: 1322	Country: Norway	ID Number: 0575

Name of Notified Body for noise emission assessment: Det Norske Veritas AS			
Address: Veritasveien 1			
Town: Hovik	Post Code: 1322	Country: Norway	ID Number: 0575

Conformity assessment module used for exhaust emissions:
 B +C
 B +D
 B +E
 B +F
 G
 H

or engine type approved according to:
 stage II of Directive 97/68/EC
 Directive 88/77/EC

Conformity assessment module used for noise emissions:
 A
 Aa
 G
 H

Other Community Directives applied: Safety of Machinery Directive 98/37/EC; Electromagnetic Compatibility Directive 2004/108/EC

Description of Engines and Essential Requirements

Engine Type	Fuel Type	Combustion Cycle
<input type="checkbox"/> z or sterndrive without integral exhaust	<input type="checkbox"/> Diesel	<input type="checkbox"/> 2 stroke
<input checked="" type="checkbox"/> Outboard engine	<input checked="" type="checkbox"/> Petrol	<input checked="" type="checkbox"/> 4 stroke

Identification of Engines Covered by This Declaration of Conformity

Name of engine family	Unique engine identification number: starting serial number	EC Module H certificate number
Verado 6 cylinder 200, 225, 250, 275, 300, 350 hp	OP401000 or 1B227000	RCD-H-2
Verado 4 cylinder 135, 150, 175, 200 hp	OP401000 or 1B227000	RCD-H-2
L4NA 4 cylinder 80, 100, 115 hp	OP401000 or 1B227000	RCD-H-2

Essential requirements	standards	other normative document/ method	technical file	Please specify in more detail (* = mandatory standard)
Annex 1.B—Exhaust Emissions				
B.1 engine identification	<input type="checkbox"/>	<input type="checkbox"/>	<input checked="" type="checkbox"/>	
B.2 exhaust emission requirements	<input checked="" type="checkbox"/> *	<input type="checkbox"/>	<input type="checkbox"/>	* EN ISO 8178-1:1996
B.3 durability	<input type="checkbox"/>	<input type="checkbox"/>	<input checked="" type="checkbox"/>	
B.4 owner's manual	<input checked="" type="checkbox"/>	<input type="checkbox"/>	<input type="checkbox"/>	ISO 8665: 1995
Annex 1.C—Noise Emissions				
C.1 Noise emission levels	<input checked="" type="checkbox"/> *	<input type="checkbox"/>	<input type="checkbox"/>	EN ISO 14509
C.2 Owner's manual	<input type="checkbox"/>	<input checked="" type="checkbox"/>	<input type="checkbox"/>	Owner's manual

This declaration of conformity is issued under the sole responsibility of the manufacturer. I declare on behalf of the engine manufacturer that the engines mentioned preceding complies with all applicable essential requirements in the way specified.

Name / function:

Mark D. Schwabero, President,
Mercury Outboard



Date and place of issue:

July 24, 2008
Fond du Lac, Wisconsin, USA

WARRANTY INFORMATION

Warranty Registration.....	1
Transfer of Warranty.....	2
Transfer of Mercury Product Protection (Extended Service Coverage) Plan United States and Canada.....	2
Outboard Limited Warranty.....	3
3 Year Limited Warranty Against Corrosion.....	7
Warranty Coverage and Exclusions.....	11
U.S. EPA Emissions Limited Warranty.....	13
Emission Control System Components.....	13

General Information

Boater's Responsibilities.....	15
Before Operating Your Outboard.....	15
Boat Horsepower Capacity.....	16
High-Speed and High-Performance Boat Operation.....	16
Outboard Remote Control Models	16
Lanyard Stop Switch.....	17
Protecting People in the Water.....	20
Passenger Safety Message - Pontoon Boats and Deck Boats	21
Wave and Wake Jumping.....	22
Impact with Underwater Hazards.....	23
Exhaust Emissions.....	25
Selecting Accessories for Your Outboard.....	27
Safe Boating Suggestions.....	27
Recording Serial Number.....	29
200/225/250/275/300 Verado FourStroke Specifications.....	30
Component Identification.....	31

Installation

Installing Outboard.....	32
Propeller Selection.....	34

Transporting

Trailing Boat/Outboard	35
------------------------------	----

Fuel and Oil

Fuel Recommendations.....	37
Low Permeation Fuel Hose Requirement	39
Filling Fuel Tank.....	39
Engine Oil Recommendations.....	40
Checking and Adding Engine Oil.....	40

Features and Controls

Panel Mount Control Features and Operation.....	43
Single Handle Console Control Features and Operation.....	46
Slim Binnacle Control Features and Operation.....	51
Dual Handle Console Control Features and Operation.....	55
Dual Handle Console Control with CAN Trackpad Features and Operation.....	60
Shadow Mode Control Features and Operation.....	65
Shadow Mode Control with CAN Trackpad Features and Operation.....	73
Warning System.....	82
Power Trim and Tilt.....	84

Operation

Prestarting Check List.....	89
Operating in Freezing Temperatures.....	89
Operating in Saltwater or Polluted Water.....	90
Engine Break-in Procedure.....	90
Starting the Engine.....	90
Gear Shifting.....	93
Stopping the Engine.....	95

Maintenance

Outboard Care.....	96
EPA Emissions Regulations.....	96
Inspection and Maintenance Schedule.....	97
Flushing the Cooling System.....	100
Cowl Removal and Installation.....	101
Cleaning Care for Top and Bottom Cowls.....	102
Cleaning Care for the Powerhead (Saltwater Use).....	103
Battery Inspection	103
Verado Engine Battery Specifications.....	104
Air Filter.....	106
Fuel System.....	108
Corrosion Control Anode.....	113
Propeller Replacement.....	113
Spark Plug Inspection and Replacement.....	115
Fuses.....	117
DTS Wiring System.....	119
Accessory Drive Belt Inspection.....	119
Checking Power Trim Fluid.....	119
Checking Power Steering Fluid.....	121
Changing Engine Oil	121
Gearcase Lubrication.....	125

Storage

Storage Preparation.....	128
Protecting External Outboard Components.....	129
Protecting Internal Engine Components.....	129
Gearcase.....	129
Positioning Outboard for Storage.....	130
Battery Storage.....	130

Troubleshooting

Starter Motor Will Not Crank the Engine.....	131
Engine Will Not Start.....	131
Engine Starts But Will Not Shift Into Gear.....	131
Engine Runs Erratically.....	132
Performance Loss.....	132
Battery Will Not Hold Charge.....	132

Owner Service Assistance

Local Repair Service.....	134
Service Away from Home.....	134
Parts and Accessories Inquiries.....	134
Service Assistance.....	134
Mercury Marine Service Offices.....	135

WARRANTY INFORMATION

Warranty Registration

UNITED STATES AND CANADA

To be eligible for warranty coverage, the product must be registered with Mercury Marine.

At the time of sale, the selling dealer should complete the warranty registration and immediately submit it to Mercury Marine via MercNET, e-mail, or mail. Upon receipt of this warranty registration, Mercury Marine will record the registration.

A copy of the warranty registration should be provided to you by your selling dealer.

NOTE: *Registration lists must be maintained by Mercury Marine and any dealer on marine products sold in the United States, should a safety recall notification under the Federal Safety Act be required.*

You may change your address at any time, including at time of warranty claim, by calling Mercury Marine or sending a letter or fax with your name, old address, new address, and engine serial number to Mercury Marine's warranty registration department.

Your dealer can also process this change of information.

Mercury Marine

Attn: Warranty Registration Department

W6250 W. Pioneer Road

P.O. Box 1939

Fond du Lac, WI 54936-1939

920-929-5054

Fax +1 920 929 5893

OUTSIDE UNITED STATES AND CANADA

For products purchased outside the United States and Canada, contact the distributor in your country, or the Marine Power Service Center closest to you.

WARRANTY INFORMATION

Transfer of Warranty

UNITED STATES AND CANADA

The limited warranty is transferable to a subsequent purchaser, but only for the remainder of the unused portion of the limited warranty. This will not apply to products used for commercial applications.

To transfer the warranty to the subsequent owner, send or fax a copy of the bill of sale or purchase agreement, new owner's name, address, and engine serial number to Mercury Marine's warranty registration department. In the United States and Canada, mail to:

Mercury Marine
Attn: Warranty Registration Department
W6250 W. Pioneer Road
P.O. Box 1939
Fond du Lac, WI 54936-1939
920-929-5054
Fax +1 920 929 5893

Upon processing the transfer of warranty, Mercury Marine will record the new owner's information.

There is no charge for this service.

OUTSIDE THE UNITED STATES AND CANADA

For products purchased outside the United States and Canada, contact the distributor in your country, or the Marine Power Service Center closest to you.

Transfer of Mercury Product Protection (Extended Service Coverage) Plan United States and Canada

The remaining coverage period of the Product Protection Plan is transferable to the subsequent purchaser of the engine within thirty (30) days from the date of sale. Contracts not transferred within thirty (30) days of the subsequent purchase will no longer be valid and the product will no longer be eligible for coverage under the terms of the contract.

WARRANTY INFORMATION

To transfer the plan to the subsequent owner, contact Mercury Product Protection or an authorized dealer to receive a Request for Transfer form. Submit to Mercury Product Protection a receipt/bill of sale, a completed Request of Transfer form, and a check payable to Mercury Marine in the amount of \$50.00 (per engine) to cover the transfer fee.

Plan coverage is not transferable from one product to another product or for non-eligible applications.

The Certified Pre-Owned engine plans are not transferable.

For help or assistance, contact Mercury Product Protection Department at 1-888-427-5373 from 7:30 a.m. to 4:30 p.m. CST, Monday–Friday or email mpp_support@mercmarine.com.

Outboard Limited Warranty

UNITED STATES, CANADA, EUROPE, MIDDLE EAST, AFRICA, AND THE CONFEDERATION OF INDEPENDENT STATES

WHAT IS COVERED: Mercury Marine warrants its new products to be free of defects in material and workmanship during the period described below.

WARRANTY INFORMATION

DURATION OF COVERAGE: This Limited Warranty provides coverage for three (3) years from the date the product is first sold to a recreational use retail purchaser, or the date on which the product is first put into service, whichever occurs first.

Commercial users of these products receive warranty coverage of one (1) year from the date of first retail sale, or one (1) year from the date on which the product was first put into service, whichever occurs first. Commercial use is defined as any work or employment related use of the product, or any use of the product which generates income, for any part of the warranty period, even if the product is only occasionally used for such purposes.

The repair or replacement of parts, or the performance of service under this warranty, does not extend the life of this warranty beyond its original expiration date. Unexpired warranty coverage can be transferred from one recreational use customer to a subsequent recreational use customer upon proper reregistration of the product. Unexpired warranty coverage cannot be transferred either to or from a commercial use customer.

Warranty coverage may be terminated for used repossessed product; or product purchased at auction, from a salvage yard, or from an insurance company.

CONDITIONS THAT MUST BE MET IN ORDER TO OBTAIN WARRANTY COVERAGE: Warranty coverage is available only to retail customers that purchase from a Dealer authorized by Mercury Marine to distribute the product in the country in which the sale occurred, and then only after the Mercury Marine specified predelivery inspection process is completed and documented. Warranty coverage becomes available upon proper registration of the product by the authorized dealer. Inaccurate warranty registration information regarding recreational use, or subsequent change of use from recreational to commercial (unless properly reregistered) may void the warranty at the sole discretion of Mercury Marine. Routine maintenance outlined in the Operation and Maintenance Manual must be timely performed in order to maintain warranty coverage. Mercury Marine reserves the right to make warranty coverage contingent upon proof of proper maintenance.

WARRANTY INFORMATION

WHAT MERCURY WILL DO: Mercury's sole and exclusive obligation under this warranty is limited to, at our option, repairing a defective part, replacing such part or parts with new or Mercury Marine certified remanufactured parts, or refunding the purchase price of the Mercury product. Mercury reserves the right to improve or modify products from time to time without assuming an obligation to modify products previously manufactured.

HOW TO OBTAIN WARRANTY COVERAGE: The customer must provide Mercury with a reasonable opportunity to repair, and reasonable access to the product for warranty service. Warranty claims shall be made by delivering the product for inspection to a Mercury dealer authorized to service the product. If purchaser cannot deliver the product to such a dealer, written notice must be given to Mercury. We will then arrange for the inspection and any covered repair. Purchaser, in that case, shall pay for all related transportation charges and/or travel time. If the service provided is not covered by this warranty, purchaser shall pay for all related labor and material, and any other expenses associated with that service. Purchaser shall not, unless requested by Mercury, ship the product or parts of the product directly to Mercury. Proof of registered ownership must be presented to the dealer at the time warranty service is requested in order to obtain coverage.

WARRANTY INFORMATION

WHAT IS NOT COVERED: This limited warranty does not cover routine maintenance items, tune-ups, adjustments, normal wear and tear, damage caused by abuse, abnormal use, use of a propeller or gear ratio that does not allow the engine to run in its recommended wide-open throttle RPM range (see the Operation and Maintenance Manual), operation of the product in a manner inconsistent with the recommended operation/duty cycle section of the Operation and Maintenance Manual, neglect, accident, submersion, improper installation (proper installation specifications and techniques are set forth in the installation instructions for the product), improper service, use of an accessory or part not manufactured or sold by us, jet pump impellers and liners, operation with fuels, oils or lubricants which are not suitable for use with the product (see the Operation and Maintenance Manual), alteration or removal of parts, water entering the engine through the fuel intake, air intake or exhaust system, or damage to the product from insufficient cooling water caused by blockage of the cooling system by a foreign body, running the engine out of water, mounting the engine too high on the transom, or running the boat with the engine trimmed out too far. Use of the product for racing or other competitive activity, or operating with a racing type lower unit, at any point, even by a prior owner of the product, voids the warranty.

Expenses related to haul-out, launch, towing, storage, telephone, rental, inconvenience, slip fees, insurance coverage, loan payments, loss of time, loss of income, or any other type of incidental or consequential damages are not covered by this warranty. Also, expenses associated with the removal and/or replacement of boat partitions or material caused by boat design for access to the product are not covered by this warranty.

No individual or entity, including Mercury Marine authorized dealers, has been given authority by Mercury Marine to make any affirmation, representation or warranty regarding the product, other than those contained in this limited warranty, and if made, shall not be enforceable against Mercury Marine.

WARRANTY INFORMATION

For additional information regarding events and circumstances covered by this warranty, and those that are not, see the Warranty Coverage section of the Operation and Maintenance Manual, incorporated by reference into this warranty.

DISCLAIMERS AND LIMITATIONS:

THE IMPLIED WARRANTIES OF MERCHANTABILITY AND FITNESS FOR A PARTICULAR PURPOSE ARE EXPRESSLY DISCLAIMED. TO THE EXTENT THAT THEY CANNOT BE DISCLAIMED, THE IMPLIED WARRANTIES ARE LIMITED IN DURATION TO THE LIFE OF THE EXPRESS WARRANTY. INCIDENTAL AND CONSEQUENTIAL DAMAGES ARE EXCLUDED FROM COVERAGE UNDER THIS WARRANTY. SOME STATES/COUNTRIES DO NOT ALLOW FOR THE DISCLAIMERS, LIMITATIONS AND EXCLUSIONS IDENTIFIED ABOVE, AS A RESULT, THEY MAY NOT APPLY TO YOU. THIS WARRANTY GIVES YOU SPECIFIC LEGAL RIGHTS, AND YOU MAY ALSO HAVE OTHER LEGAL RIGHTS WHICH VARY FROM STATE TO STATE AND COUNTRY TO COUNTRY.

3 Year Limited Warranty Against Corrosion

WHAT IS COVERED: Mercury Marine warrants that each new Mercury, Mariner, Mercury Racing, Sport Jet, M² Jet Drive, Tracker by Mercury Marine Outboard, Mercury MerCruiser Inboard or Sterndrive Engine (Product) will not be rendered inoperative as a direct result of corrosion for the period of time described below.

DURATION OF COVERAGE: This limited corrosion warranty provides coverage for three (3) years from either the date the product is first sold, or the date on which the product is first put into service, whichever occurs first. The repair or replacement of parts, or the performance of service under this warranty, does not extend the life of this warranty beyond its original expiration date. Unexpired warranty coverage can be transferred to subsequent (noncommercial use) purchaser upon proper reregistration of the product.

WARRANTY INFORMATION

CONDITIONS THAT MUST BE MET IN ORDER TO OBTAIN

WARRANTY COVERAGE: Warranty coverage is available only to retail customers that purchase from a Dealer authorized by Mercury Marine to distribute the product in the country in which the sale occurred, and then only after the Mercury Marine specified predelivery inspection process is completed and documented. Warranty coverage becomes available upon proper registration of the product by the authorized dealer. Corrosion prevention devices specified in the Operation and Maintenance Manual must be in use on the boat, and routine maintenance outlined in the Operation and Maintenance Manual must be timely performed (including, without limitation, the replacement of sacrificial anodes, use of specified lubricants, and touch-up of nicks and scratches) in order to maintain warranty coverage. Mercury Marine reserves the right to make warranty coverage contingent upon proof of proper maintenance.

WHAT MERCURY WILL DO: Mercury's sole and exclusive obligation under this warranty is limited to, at our option, repairing a corroded part, replacing such part or parts with new or Mercury Marine certified remanufactured parts, or refunding the purchase price of the Mercury product. Mercury reserves the right to improve or modify products from time to time without assuming an obligation to modify products previously manufactured.

WARRANTY INFORMATION

HOW TO OBTAIN WARRANTY COVERAGE: The customer must provide Mercury with a reasonable opportunity to repair, and reasonable access to the product for warranty service. Warranty claims shall be made by delivering the product for inspection to a Mercury dealer authorized to service the product. If purchaser cannot deliver the product to such a dealer, written notice must be given to Mercury. We will then arrange for the inspection and any covered repair. Purchaser, in that case, shall pay for all related transportation charges and/or travel time. If the service provided is not covered by this warranty, purchaser shall pay for all related labor and material, and any other expenses associated with that service. Purchaser shall not, unless requested by Mercury, ship the product or parts of the product directly to Mercury. Proof of registered ownership must be presented to the dealer at the time warranty service is requested in order to obtain coverage.

WHAT IS NOT COVERED: This limited warranty does not cover electrical system corrosion; corrosion resulting from damage, corrosion which causes purely cosmetic damage, abuse, or improper service; corrosion to accessories, instruments, steering systems; corrosion to factory installed jet drive unit; damage due to marine growth; product sold with less than a one year limited Product warranty; replacement parts (parts purchased by customer); products used in a commercial application. Commercial use is defined as any work or employment related use of the product, or any use of the product which generates income, for any part of the warranty period, even if the product is only occasionally used for such purposes.

WARRANTY INFORMATION

Corrosion damage caused by stray electrical currents (onshore power connections, nearby boats, submerged metal) is not covered by this corrosion warranty and should be protected against by the use of a corrosion protection system, such as the Mercury Precision Parts or Quicksilver MerCathode system and/or Galvanic Isolator. Corrosion damage caused by improper application of copper base antifouling paints is also not covered by this limited warranty. If antifouling protection is required, Tri-Butyl-Tin-Adipate (TBTA) base antifouling paints are recommended on Outboard and MerCruiser boating applications. In areas where TBTA base paints are prohibited by law, copper base paints can be used on the hull and transom. Do not apply paint to the outboard or MerCruiser product. In addition, care must be taken to avoid an electrical interconnection between the warranted product and the paint. For MerCruiser product, an unpainted gap of at least 38 mm (1.5 in.) should be left around the transom assembly. Refer to the Operation and Maintenance Manual for additional details.

For additional information regarding events and circumstances covered by this warranty, and those that are not, see the Warranty Coverage section of the Operation and Maintenance Manual, incorporated by reference into this warranty.

DISCLAIMERS AND LIMITATIONS:

THE IMPLIED WARRANTIES OF MERCHANTABILITY AND FITNESS FOR A PARTICULAR PURPOSE ARE EXPRESSLY DISCLAIMED. TO THE EXTENT THAT THEY CANNOT BE DISCLAIMED, THE IMPLIED WARRANTIES ARE LIMITED IN DURATION TO THE LIFE OF THE EXPRESS WARRANTY. INCIDENTAL AND CONSEQUENTIAL DAMAGES ARE EXCLUDED FROM COVERAGE UNDER THIS WARRANTY. SOME STATES/COUNTRIES DO NOT ALLOW FOR THE DISCLAIMERS, LIMITATIONS AND EXCLUSIONS IDENTIFIED ABOVE, AS A RESULT, THEY MAY NOT APPLY TO YOU. THIS WARRANTY GIVES YOU SPECIFIC LEGAL RIGHTS, AND YOU MAY ALSO HAVE OTHER LEGAL RIGHTS WHICH VARY FROM STATE TO STATE AND COUNTRY TO COUNTRY.

WARRANTY INFORMATION

Warranty Coverage and Exclusions

The purpose of this section is to help eliminate some of the more common misunderstandings regarding warranty coverage. The following information explains some of the types of services that are not covered by warranty. The provisions set forth following have been incorporated by reference into the Three Year Limited Warranty Against Corrosion Failure, the International Limited Outboard Warranty, and the United States and Canada Limited Outboard Warranty.

Keep in mind that warranty covers repairs that are needed within the warranty period because of defects in material and workmanship. Installation errors, accidents, normal wear, and a variety of other causes that affect the product are not covered.

Warranty is limited to defects in material or workmanship, but only when the consumer sale is made in the country to which distribution is authorized by us.

Should you have any questions concerning warranty coverage, contact your authorized dealer. They will be pleased to answer any questions that you may have.

GENERAL EXCLUSIONS FROM WARRANTY

1. Minor adjustments and tune-ups, including checking, cleaning, or adjusting spark plugs, ignition components, carburetor settings, filters, belts, controls, and checking lubrication made in connection with normal services.
2. Factory installed jet drive units - Specific parts excluded from the warranty are: the jet drive impeller and jet drive liner damaged by impact or wear, and water damaged driveshaft bearings as a result of improper maintenance.
3. Damage caused by neglect, lack of maintenance, accident, abnormal operation, or improper installation or service.
4. Haul-out, launch, towing charges, removal and/or replacement of boat partitions or material because of boat design for necessary access to the product, all related transportation charges and/or travel time, etc. Reasonable access must be provided to the product for warranty service. Customer must deliver product to an authorized dealer.

WARRANTY INFORMATION

5. Additional service work requested by customer other than that necessary to satisfy the warranty obligation.
6. Labor performed by other than an authorized dealer may be covered only under the following circumstances: when performed on emergency basis (providing there are no authorized dealers in the area who can perform the work required or have no facilities to haul-out, etc., and prior factory approval has been given to have the work performed at this facility).
7. All incidental and/or consequential damages (storage charges, telephone or rental charges of any type, inconvenience or loss of time or income) are the owner's responsibility.
8. Use of other than Mercury Precision or Quicksilver parts when making warranty repairs.
9. Oils, lubricants, or fluids changed as a matter of normal maintenance is customer's responsibility unless loss or contamination of same is caused by product failure that would be eligible for warranty consideration.
10. Participating in or preparing for racing or other competitive activity or operating with a racing type lower unit.
11. Engine noise does not necessarily indicate a serious engine problem. If diagnosis indicates a serious internal engine condition which could result in a failure, condition responsible for noise should be corrected under the warranty.
12. Lower unit and/or propeller damage caused by striking a submerged object is considered a marine hazard.
13. Water entering engine through the fuel intake, air intake, or exhaust system or submersion.
14. Failure of any parts caused by lack of cooling water, which results from starting motor out of water, foreign material blocking inlet holes, motor being mounted too high, or trimmed too far out.
15. Use of fuels and lubricants which are not suitable for use with or on the product. Refer to the **Maintenance** section.

WARRANTY INFORMATION

16. Our limited warranty does not apply to any damage to our products caused by the installation or use of parts and accessories which are not manufactured or sold by us. Failures which are not related to the use of those parts or accessories are covered under warranty if they otherwise meet the terms of the limited warranty for that product.

U.S. EPA Emissions Limited Warranty

Consistent with the obligations created by 40 CFR Part 1045, Subpart B, Mercury Marine provides a five year or 175 hours of engine use, whichever occurs first, to the retail customer, that the engine is designed, built, and equipped so as to conform at the time of sale with applicable regulations under section 213 of the Clean Air Act, and that the engine is free from defects in materials and workmanship which cause the engine to fail to conform with applicable regulations. This emission-related warranty covers all the components listed in the **Emission Control System Components**.

Emission Control System Components

The EPA and California emission-related warranty covers all the following list of components:

COMPONENTS OF THE EMISSIONS CONTROL SYSTEM:

1. Fuel metering system
 - a. Carburetor and internal parts (and/or pressure regulator or fuel injection system)
 - b. Cold start enrichment system
 - c. Intake valves
2. Air induction system
 - a. Intake manifold
 - b. Turbocharger or supercharger systems (where applicable)
3. Ignition system
 - a. Spark plugs
 - b. Magneto or electronic ignition system
 - c. Spark advance/retard system

WARRANTY INFORMATION

- d. Ignition coil and/or control module
- e. Ignition wires
- 4. Lubrication system (4-Stroke engines excluded)
 - a. Oil pump and internal parts
 - b. Oil injectors
 - c. Oil meter
- 5. Exhaust system
 - a. Exhaust manifold
 - b. Exhaust valves
- 6. Miscellaneous items used in above systems
 - a. Hoses, clamps, fittings, tubing, sealing gaskets or devices, and mounting hardware
 - b. Pulleys, belts, and idlers
 - c. Vacuum, temperature, check and time sensitive valves and switches
 - d. Electronic controls

The emission-related warranty does not cover components whose failure would not increase an engine's emissions on any regulated pollutant.

GENERAL INFORMATION

Boater's Responsibilities

The operator (driver) is responsible for the correct and safe operation of the boat and safety of its occupants and general public. It is strongly recommended that each operator (driver) read and understand this entire manual before operating the outboard.

Be sure at least one additional person onboard is instructed in the basics of starting and operating the outboard and boat handling in case the driver is unable to operate the boat.

Before Operating Your Outboard

Read this manual carefully. Learn how to operate your outboard properly. If you have any questions, contact your dealer.

Safety and operating information that is practiced, along with using good common sense, can help prevent personal injury and product damage.

This manual as well as safety labels posted on the outboard use the following safety alerts to draw your attention to special safety instructions that should be followed.

DANGER

Indicates a hazardous situation which, if not avoided, will result in death or serious injury.

WARNING

Indicates a hazardous situation which, if not avoided, could result in death or serious injury.

CAUTION

Indicates a hazardous situation which, if not avoided, could result in minor or moderate injury.

NOTICE

Indicates a situation which, if not avoided, could result in engine or major component failure.

GENERAL INFORMATION

Boat Horsepower Capacity

WARNING

Exceeding the boat's maximum horsepower rating can cause serious injury or death. Overpowering the boat can affect boat control and flotation characteristics or break the transom. Do not install an engine that exceeds the boat's maximum power rating.

Do not overpower or overload your boat. Most boats will carry a required capacity plate indicating the maximum acceptable power and load as determined by the manufacturer following certain federal guidelines. If in doubt, contact your dealer or the boat manufacturer.

U.S. COAST GUARD CAPACITY	
MAXIMUM HORSEPOWER	XXX
MAXIMUM PERSON CAPACITY (POUNDS)	XXX
MAXIMUM WEIGHT CAPACITY	XXX

26777

High-Speed and High-Performance Boat Operation

If your outboard is to be used on a high-speed or high-performance boat with which you are unfamiliar, we recommend that you never operate it at its high speed capability without first requesting an initial orientation and familiarization demonstration ride with your dealer or an operator experienced with your boat/outboard combination. For additional information, obtain a copy of our **Hi-Performance Boat Operation** booklet from your dealer, distributor, or Mercury Marine.

Outboard Remote Control Models

The outboard must be equipped with a Mercury remote control designed for digital throttle and shift. Start-in-gear protection is provided by the remote control system.

GENERAL INFORMATION

Lanyard Stop Switch

The purpose of a lanyard stop switch is to turn off the engine when the operator moves far enough away from the operator's position (as in accidental ejection from the operator's position) to activate the switch. Tiller handle outboards and some remote control units are equipped with a lanyard stop switch. A lanyard stop switch can be installed as an accessory - generally on the dashboard or side adjacent to the operator's position.

The lanyard is a cord usually 122–152 cm (4–5 feet) in length when stretched out, with an element on one end made to be inserted into the switch and a snap on the other end for attaching to the operator. The lanyard is coiled to make its at-rest condition as short as possible to minimize the likelihood of lanyard entanglement with nearby objects. Its stretched-out length is made to minimize the likelihood of accidental activation should the operator choose to move around in an area close to the normal operator's position. If it is desired to have a shorter lanyard, wrap the lanyard around the operator's wrist or leg, or tie a knot in the lanyard.

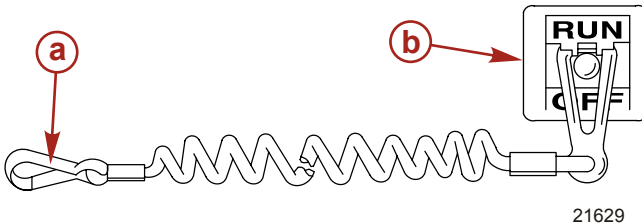

- a** - Lanyard cord
- b** - Lanyard stop switch

Read the following Safety Information before proceeding.

GENERAL INFORMATION

Important Safety Information: The purpose of a lanyard stop switch is to stop the engine when the operator moves far enough away from the operator's position to activate the switch. This would occur if the operator accidentally falls overboard or moves within the boat a sufficient distance from the operator's position. Falling overboard and accidental ejections are more likely to occur in certain types of boats such as low sided inflatables, bass boats, high performance boats, and light, sensitive handling fishing boats operated by a hand tiller. Falling overboard and accidental ejections are also likely to occur as a result of poor operating practices such as sitting on the back of the seat or gunwale at planing speeds, standing at planing speeds, sitting on elevated fishing boat decks, operating at planing speeds in shallow or obstacle infested waters, releasing your grip on a steering wheel or tiller handle that is pulling in one direction, drinking alcohol or consuming drugs, or daring high speed boat maneuvers.

While activation of the lanyard stop switch will stop the engine immediately, a boat will continue to coast for some distance depending upon the velocity and degree of any turn at shut down. However, the boat will not complete a full circle. While the boat is coasting, it can cause injury to anyone in the boat's path as seriously as the boat would when under power.

We strongly recommend that other occupants be instructed on proper starting and operating procedures should they be required to operate the engine in an emergency (e.g. if the operator is accidentally ejected).

WARNING

If the operator falls out of the boat, stop the engine immediately to reduce the possibility of serious injury or death from being struck by the boat. Always properly connect the operator to the stop switch using a lanyard.

GENERAL INFORMATION

WARNING

Avoid serious injury or death from deceleration forces resulting from accidental or unintended stop switch activation. The boat operator should never leave the operator's station without first disconnecting the stop switch lanyard from the operator.

Accidental or unintended activation of the switch during normal operation is also a possibility. This could cause any, or all, of the following potentially hazardous situations:

- Occupants could be thrown forward due to unexpected loss of forward motion - a particular concern for passengers in the front of the boat who could be ejected over the bow and possibly struck by the gearcase or propeller.
- Loss of power and directional control in heavy seas, strong current, or high winds.
- Loss of control when docking.

KEEP THE LANYARD STOP SWITCH AND LANYARD CORD IN GOOD OPERATING CONDITION

Before each use, check to ensure the lanyard stop switch works properly. Start the engine and stop it by pulling the lanyard cord. If the engine does not stop, have the switch repaired before operating the boat.

Before each use, visually inspect the lanyard cord to ensure it is in good working condition and that there are no breaks, cuts, or wear to the cord. Check that the clips on the ends of the cord are in good condition. Replace any damaged or worn lanyard cords.

GENERAL INFORMATION

Protecting People in the Water

WHILE YOU ARE CRUISING

It is very difficult for a person standing or floating in the water to take quick action to avoid a boat heading in his/her direction, even at slow speed.



Always slow down and exercise extreme caution any time you are boating in an area where there might be people in the water. Whenever a boat is moving (coasting) and the outboard gear shift is in neutral position, there is sufficient force by the water on the propeller to cause the propeller to rotate. This neutral propeller rotation can cause serious injury.

WHILE BOAT IS STATIONARY

WARNING

A spinning propeller, a moving boat, or any solid device attached to the boat can cause serious injury or death to swimmers. Stop the engine immediately whenever anyone in the water is near your boat.

Shift outboard into neutral and shut off the engine before allowing people to swim or be in the water near your boat.

GENERAL INFORMATION

Passenger Safety Message - Pontoon Boats and Deck Boats

Whenever the boat is in motion, observe the location of all passengers. Do not allow any passengers to stand or use seats other than those designated for traveling faster than idle speed. A sudden reduction in boat speed, such as plunging into a large wave or wake, a sudden throttle reduction, or a sharp change of boat direction, could throw them over the front of the boat. Falling over the front of the boat between the two pontoons will position them to be run over by the outboard.

BOATS HAVING AN OPEN FRONT DECK

No one should ever be on the deck in front of the fence while the boat is in motion. Keep all passengers behind the front fence or enclosure.

Persons on the front deck could easily be thrown overboard or persons dangling their feet over the front edge could get their legs caught by a wave and pulled into the water.

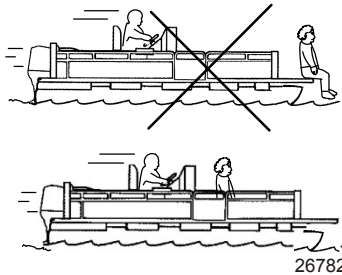

⚠ WARNING

Sitting or standing in an area of the boat not designed for passengers at speeds above idle can cause serious injury or death. Stay back from the front end of deck boats or raised platforms and remain seated while the boat is in motion.

GENERAL INFORMATION

BOATS WITH FRONT MOUNTED, RAISED PEDESTAL FISHING SEATS

Elevated fishing seats are not intended for use when the boat is traveling faster than idle or trolling speed. Sit only in seats designated for traveling at faster speeds.

Any unexpected, sudden reduction in boat speed could result in the elevated passenger falling over the front of the boat.

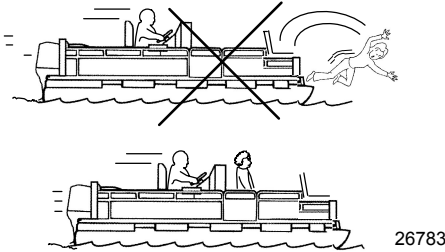

Wave and Wake Jumping

Operating recreational boats over waves and wake is a natural part of boating. However, when this activity is done with sufficient speed to force the boat hull partially or completely out of the water, certain hazards arise, particularly when the boat reenters the water.

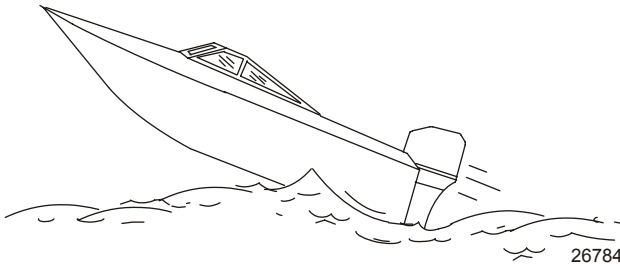

The primary concern is the boat changing direction while in the midst of the jump. In such case, the landing may cause the boat to veer violently in a new direction. Such a sharp change in direction can cause occupants to be thrown out of their seats, or out of the boat.

GENERAL INFORMATION

⚠ WARNING

Wave or wake jumping can cause serious injury or death from occupants being thrown within or out of the boat. Avoid wave or wake jumping whenever possible.

There is another less common hazardous result from allowing your boat to launch off a wave or wake. If the bow of your boat pitches down far enough while airborne, upon water contact it may penetrate under the water surface and submarine for an instant. This will bring the boat to a nearly instantaneous stop and can send the occupants flying forward. The boat may also steer sharply to one side.

Impact with Underwater Hazards

Reduce speed and proceed with caution whenever you drive a boat in shallow water areas, or in areas where you suspect underwater obstacles may exist which could be struck by the outboard or the boat bottom. **The most important thing you can do to help reduce injury or impact damage from striking a floating or underwater object is to control the boat speed. Under these conditions, boat speed should be kept to a minimum planing speed of 24 to 40 km/h (15 to 25 MPH).**

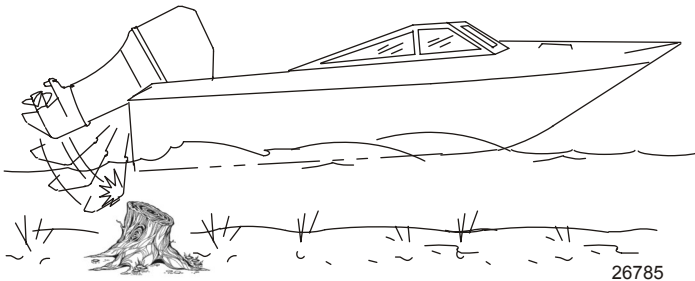

Striking a floating or underwater object could result in an infinite number of situations. Some of these situations could result in the following:

- Part of the outboard or the entire outboard could break loose and fly into the boat.

GENERAL INFORMATION

- The boat could move suddenly in a new direction. Such a sharp change in direction can cause occupants to be thrown out of their seats or out of the boat.
- A rapid reduction in speed. This will cause occupants to be thrown forward, or even out of the boat.
- Impact damage to the outboard and/or boat.

Keep in mind, the most important thing you can do to help reduce injury or impact damage during an impact is control the boat speed. Boat speed should be kept to a minimum planing speed when driving in waters known to have underwater obstacles.

After striking a submerged object, stop the engine as soon as possible and inspect it for any broken or loose parts. If damage is present or suspected, the outboard should be taken to an authorized dealer for a thorough inspection and necessary repair.

The boat should also be checked for any hull fractures, transom fractures, or water leaks.

Operating a damaged outboard could cause additional damage to other parts of the outboard, or could affect control of the boat. If continued running is necessary, do so at greatly reduced speeds.

WARNING

Operating a boat or engine with impact damage can result in product damage, serious injury, or death. If the vessel experiences any form of impact, have an authorized Mercury Marine dealer inspect and repair the vessel or power package.

GENERAL INFORMATION

Exhaust Emissions

BE ALERT TO CARBON MONOXIDE POISONING

Carbon monoxide (CO) is a deadly gas that is present in the exhaust fumes of all internal combustion engines, including the engines that propel boats, and the generators that power boat accessories. By itself, CO is odorless, colorless, and tasteless, but if you can smell or taste engine exhaust, you are inhaling CO.

Early symptoms of carbon monoxide poisoning, which are similar to the symptoms of seasickness and intoxication, include headache, dizziness, drowsiness, and nausea.

WARNING

Inhaling engine exhaust gases can result in carbon monoxide poisoning, which can lead to unconsciousness, brain damage, or death. Avoid exposure to carbon monoxide.

Stay clear from exhaust areas when engine is running. Keep the boat well-ventilated while at rest or underway.

STAY CLEAR OF EXHAUST AREAS

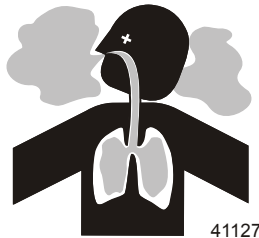

Engine exhaust gases contain harmful carbon monoxide. Avoid areas of concentrated engine exhaust gases. When engines are running, keep swimmers away from the boat, and do not sit, lie, or stand on swim platforms or boarding ladders. While underway, do not allow passengers to be positioned immediately behind the boat (platform dragging, teak/body surfing). This dangerous practice not only places a person in an area of high engine exhaust concentration, but also subjects them to the possibility of injury from the boat propeller.

GENERAL INFORMATION

GOOD VENTILATION

Ventilate the passenger area, open side curtains or forward hatches to remove fumes.

Example of desired air flow through the boat:

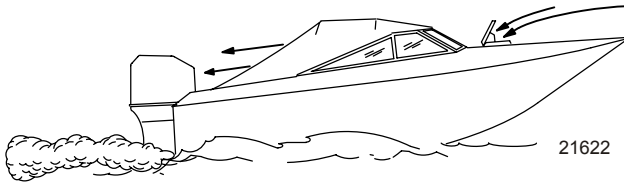

POOR VENTILATION

Under certain running and/or wind conditions, permanently enclosed or canvas enclosed cabins or cockpits with insufficient ventilation may draw in carbon monoxide. Install one or more carbon monoxide detectors in your boat.

Although the occurrence is rare, on a very calm day, swimmers and passengers in an open area of a stationary boat that contains, or is near, a running engine may be exposed to a hazardous level of carbon monoxide.

1. Examples of poor ventilation while the boat is stationary:

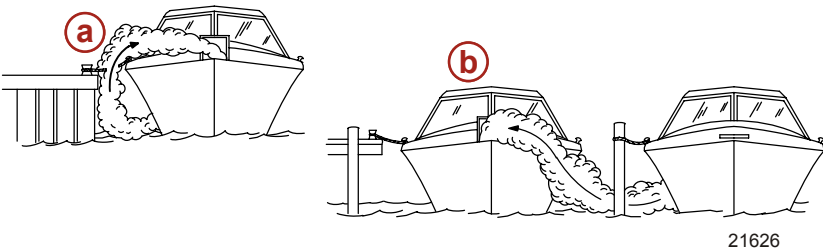

- a** - Operating the engine when the boat is moored in a confined space
- b** - Mooring close to another boat that has its engine operating

GENERAL INFORMATION

2. Examples of poor ventilation while the boat is moving:



- a** - Operating the boat with the trim angle of the bow too high
- b** - Operating the boat with no forward hatches open (station wagon effect)

Selecting Accessories for Your Outboard

Genuine Mercury Precision or Quicksilver Accessories have been specifically designed and tested for your outboard. These accessories are available from Mercury Marine dealers.

IMPORTANT: Check with your dealer before installing accessories. The misuse of approved accessories or the use of nonapproved accessories can damage the product.

Some accessories not manufactured or sold by Mercury Marine are not designed to be safely used with your outboard or outboard operating system. Acquire and read the installation, operation and maintenance manuals for all your selected accessories.

Safe Boating Suggestions

In order to safely enjoy the waterways, familiarize yourself with local and other governmental boating regulations and restrictions, and consider the following suggestions.

Use flotation devices. Have an approved personal flotation device of suitable size for each person aboard (it is the law) and have it readily accessible.

Do not overload your boat. Most boats are rated and certified for maximum load (weight) capacities (refer to your boat capacity plate). If in doubt, contact your dealer or the boat's manufacturer.

Perform safety checks and required maintenance. Follow a regular schedule and ensure that all repairs are properly made.

GENERAL INFORMATION

Know and obey all nautical rules and laws of the waterways.

Boat operators should complete a boating safety course.

Courses are offered in the U.S.A. by 1) the U.S. Coast Guard Auxiliary, 2) the Power Squadron, 3) the Red Cross, and 4) your state boating law enforcement agency. Inquiries may be made to the Boating Hotline, 1-800-368-5647 or the Boat U.S. Foundation information number 1-800-336-BOAT.

Make sure everyone in the boat is properly seated. Do not allow anyone to sit or ride on any part of the boat that was not intended for such use. This includes the back of seats, gunwales, transom, bow, decks, raised fishing seats, any rotating fishing seat; or anywhere that an unexpected acceleration, sudden stopping, unexpected loss of boat control, or sudden boat movement could cause a person to be thrown overboard or into the boat.

Never be under the influence of alcohol or drugs while boating (it is the law). Alcohol or drug use impairs your judgment and greatly reduces your ability to react quickly.

Prepare other boat operators. Instruct at least one other person onboard in the basics of starting and operating the outboard, and boat handling, in case the driver becomes disabled or falls overboard.

Passenger boarding. Stop the engine whenever passengers are boarding, unloading, or are near the back (stern) of the boat. Just shifting the outboard into neutral is not sufficient.

Be alert. The operator of the boat is responsible by law to maintain a proper lookout by sight and hearing. The operator must have an unobstructed view particularly to the front. No passengers, load, or fishing seats should block the operator's view when operating the boat above idle speed.

Never drive your boat directly behind a water-skier in case the skier falls. As an example, your boat traveling at 40 km/h (25 MPH) will overtake a fallen skier 61 m (200 ft) in front of you in 5 seconds.

GENERAL INFORMATION

Watch fallen skiers. When using your boat for waterskiing or similar activities, always keep a fallen or down skier on the operator's side of the boat while returning to assist the skier. The operator should always have the down skier in sight and never back up to the skier or anyone in the water.

Report accidents. Boat operators are required by law to file a Boating Accident Report with their state boating law enforcement agency when their boat is involved in certain boating accidents. A boating accident must be reported if 1) there is loss of life or probable loss of life, 2) there is personal injury requiring medical treatment beyond first aid, 3) there is damage to boats or other property where the damage value exceeds \$500.00, or 4) there is complete loss of the boat. Seek further assistance from local law enforcement.

Recording Serial Number

It is important to record this number for future reference. The serial number is located on the outboard as shown.

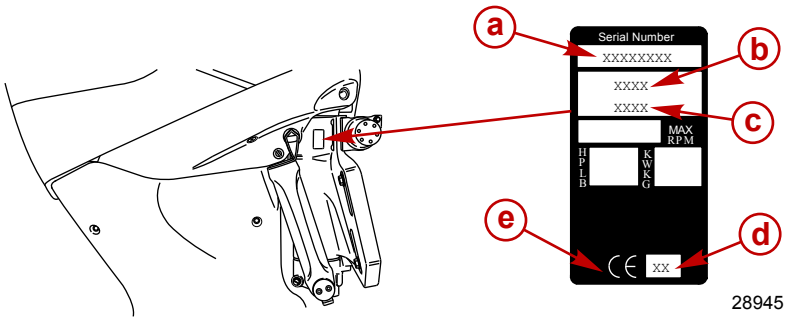

- a** - Serial number
- b** - Model year
- c** - Model designation
- d** - Year manufactured
- e** - Certified Europe Insignia (as applicable)

GENERAL INFORMATION

200/225/250/275/300 Verado FourStroke Specifications

Models	200	225	250	275	300
Horsepower	200	225	250	275	300
Kilowatts	147	165	184	202	221
Full throttle RPM range	5800–6400				
Idle speed in neutral gear ¹	550 RPM				
Number of cylinders	6				
Piston displacement	2,598 cc (158.5 cid)				
Cylinder bore	82 mm (3.23 in.)				
Stroke	82 mm (3.23 in.)				
Valve clearance (cold)					
Intake valve	0.150–0.270 mm (0.0059–0.0106 in.)				
Exhaust valve	0.350–0.470 mm (0.0137–0.0185 in.)				
Recommended spark plug	NGK ILFR6G-E				
Spark plug gap	0.8 mm (0.0315 in.)				
Spark plug hex size	16 mm				
Gear ratio	1.85:1	1.85:1	1.85:1	1.85:1	1.75:1
Recommended gasoline	Refer to Fuel and Oil				
Recommended oil	Refer to Fuel and Oil				
Right-hand rotation gearcase lubricant capacity	970 mL (32.8 fl oz)				
Left-hand rotation gearcase lubricant capacity	900 mL (30.4 fl oz)				
Engine oil capacity with oil filter replacement	7.0 liter (7.4 US qt)				
Required starting battery type	12 volt AGM (absorbed glass mat) battery				
Required USA (SAE) starting battery type	800 minimum marine cranking amps (MCA) with a minimum reserve capacity of 135 minutes RC25 rating				
Required International (EN) starting battery type	1000 minimum cold cranking amps (CCA) with a minimum of 180 amp hours (Ah)				

1. With engine fully warmed up.

GENERAL INFORMATION

Models	200	225	250	275	300
Emission control system	Electronic engine control (EC)				
Sound at drivers ear (ICOMIA 39-94) dBA	78.8				

Component Identification

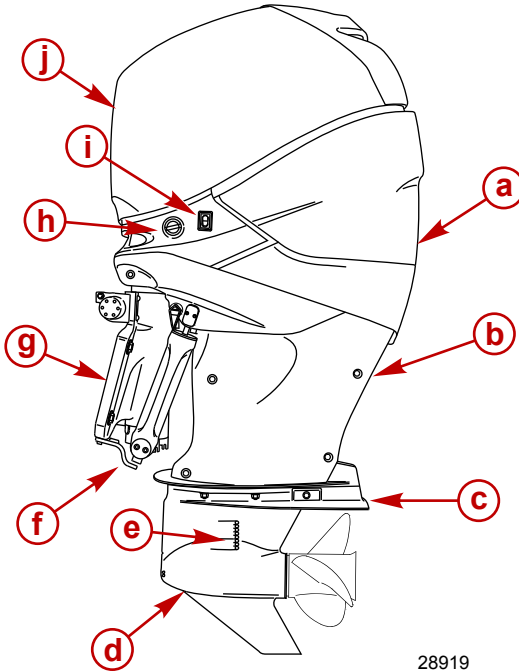

- a** - Rear cowl
- b** - Lower cowl chaps
- c** - Anti-ventilation plate
- d** - Gearcase
- e** - Cooling water intake holes
- f** - Spray plate
- g** - Pedestal
- h** - Engine flush
- i** - Auxiliary tilt switch
- j** - Top cowl

28919

INSTALLATION

Installing Outboard

WARNING

Failure to correctly fasten the outboard could result in the outboard propelling off the boat transom resulting in property damage, serious injury, or death. Before operation, the outboard must be correctly installed with the required mounting hardware. Do not accelerate above idle speed in water that may contain underwater obstacles if the outboard is not attached to the transom correctly.

IMPORTANT: For optimum boat performance and detailed engine installation instructions, refer to the outboard installation manual, supplied with the outboard.

We strongly recommend that your dealer install your outboard and related accessories to ensure proper installation and good performance. If you install the outboard yourself, follow instructions in the Outboard Installation Manual which is provided with the outboard.

The outboard must be secured to the boat transom with the four 12.7 mm (1/2 in.) diameter mounting bolts, locknuts and washers provided. Install two bolts through the upper set of mounting holes and two bolts through the lower set of mounting slots.

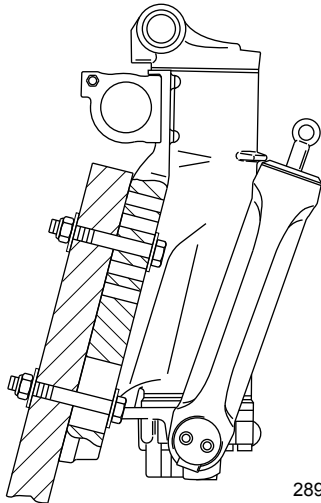

28923

INSTALLATION

MAXIMUM OUTBOARD MOUNTING HEIGHT

The mounting height of the outboard must not exceed 63.5 cm (25 in.) for L models, 76.2 cm (30 in.) for XL models, and 88.9 cm (35 in.) for XXL models. Mounting the outboard higher may cause damage to the gearcase components.

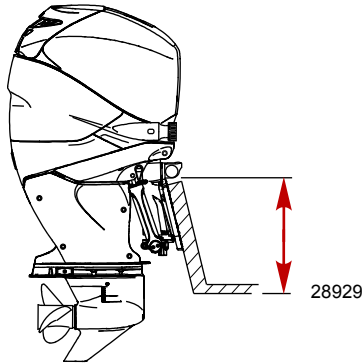

Maximum Static Waterline

The static waterline, with boat at rest, must be below the "MAX STATIC WATERLINE" mark on the idle relief grommet (located at the rear of the outboard) when the outboard is fully tilted in/down. If waterline is above "MAX STATIC WATERLINE" mark, adjust boat load forward or increase (raise) outboard mounting height to correctly place mark above waterline.

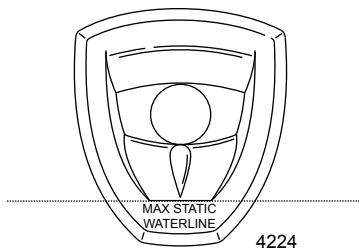

INSTALLATION

Propeller Selection

For best all around performance from your outboard/boat combination, select a propeller that allows the engine to operate in the upper half of the recommended full throttle RPM range with the boat normally loaded (refer to **General Information - Specifications**). This RPM range allows for better acceleration while maintaining maximum boat speed.

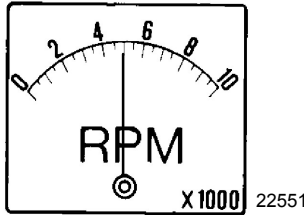

If changing conditions cause the RPM to drop below the recommended range, such as warmer, more humid weather, operation at higher elevations, increased boat load, or a dirty boat bottom/gearcase, a propeller change or cleaning may be required to maintain performance and ensure the outboards durability.

Check full-throttle RPM, using an accurate tachometer, with the engine trimmed out to a balanced-steering condition (steering effort equal in both directions) without causing the propeller to break loose.

TRANSPORTING

Trailing Boat/Outboard

When transporting the boat on a trailer, the outboard should be positioned and/or supported in one of the following ways:

1. If the boat trailer provides sufficient ground clearance, the outboard may be tilted down to the vertical operating position with no additional support required.

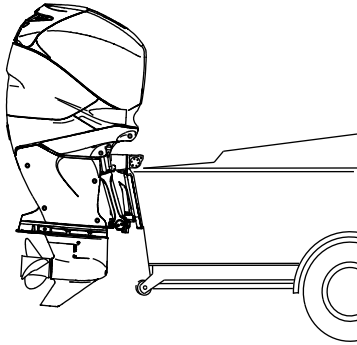

28780

2. If additional ground clearance is required, the outboard should be tilted up and supported using the outboard's tilt support bracket (trailing position) and/or an accessory transom support device. Refer to **Features and Controls - Tilting Operation**.

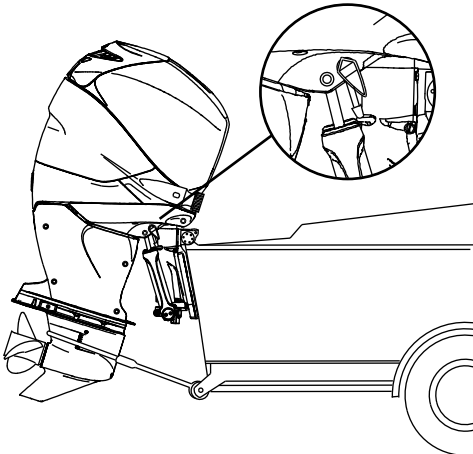

28924

TRANSPORTING

3. For maximum ground clearance, the outboard can be tilted to the full tilt position and supported using the outboards tilt support bracket and/or an accessory transom support device.

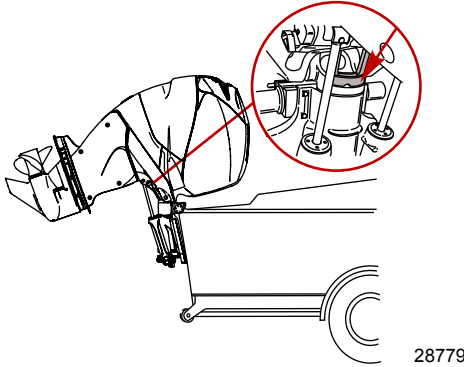

Additional clearance may be required for railroad crossings, driveways and trailer bouncing. Refer to your local dealer for recommendations.

IMPORTANT: Do not rely on the power trim/tilt system to maintain proper ground clearance for trailering. The power trim/tilt system is not intended to support the outboard for trailering.

Shift the outboard to forward gear. This prevents the propeller from spinning freely when boat is trailered.

FUEL AND OIL

Fuel Recommendations

IMPORTANT: Use of improper gasoline can damage your engine. Engine damage resulting from the use of improper gasoline is considered misuse of the engine, and damage caused thereby will not be covered under the limited warranty.

FUEL RATINGS

Mercury Marine engines will operate satisfactorily when using a major brand of unleaded gasoline meeting the following specifications:

USA and Canada - Model 275 and 300: Having a posted pump Octane Rating of 92 (R+M)/2 Octane is required for best performance. Having a posted pump Octane Rating of 87 (R+M)/2 minimum is acceptable, however, performance losses may occur. Do not use leaded gasoline.

Outside USA and Canada - Model 275 and 300: Having a posted pump Octane Rating of 96 RON is required for best performance. Having a posted pump Octane Rating of 90 RON minimum is acceptable, however, performance losses may occur. If unleaded gasoline is not available, use a major brand of leaded gasoline.

USA and Canada - Models 200/225/250: Having a posted pump Octane Rating of 87 (R+M)/2 minimum. Premium gasoline [92 (R+M)/2 Octane] is also acceptable. Do not use leaded gasoline.

Outside USA and Canada - Models 200/225/250: Having a posted pump Octane Rating of 90 RON minimum. Premium gasoline (98 RON) is also acceptable. If unleaded gasoline is not available, use a major brand of leaded gasoline.

USING REFORMULATED (OXYGENATED) GASOLINES (USA ONLY)

This type of gasoline is required in certain areas of the USA. The 2 types of oxygenates used in these fuels are Alcohol (Ethanol) or Ether (MTBE or ETBE). If Ethanol is the oxygenate that is used in the gasoline in your area, refer to **Gasolines Containing Alcohol**.

FUEL AND OIL

These Reformulated Gasolines are acceptable for use in your Mercury Marine engine.

GASOLINES CONTAINING ALCOHOL

If the gasoline in your area contains either methanol (methyl alcohol) or ethanol (ethyl alcohol), you should be aware of certain adverse effects that can occur. These adverse effects are more severe with methanol. Increasing the percentage of alcohol in the fuel can also worsen these adverse effects.

Some of these adverse effects are caused because the alcohol in the gasoline can absorb moisture from the air, resulting in a separation of the water/alcohol from the gasoline in the fuel tank.

The fuel system components on your Mercury Marine engine will withstand up to 10% alcohol content in the gasoline. We do not know what percentage your boat's fuel system will withstand. Contact your boat manufacturer for specific recommendations on the boat's fuel system components (fuel tanks, fuel lines, and fittings). Be aware that gasolines containing alcohol may cause increased:

- Corrosion of metal parts
- Deterioration of rubber or plastic parts
- Fuel permeation through rubber fuel lines
- Starting and operating difficulties

WARNING

Fuel leakage is a fire or explosion hazard, which can cause serious injury or death. Periodically inspect all fuel system components for leaks, softening, hardening, swelling, or corrosion, particularly after storage. Any sign of leakage or deterioration requires replacement before further engine operation.

Because of possible adverse effects of alcohol in gasoline, it is recommended that only alcohol-free gasoline be used where possible. If only fuel containing alcohol is available, or if the presence of alcohol is unknown, increased inspection frequency for leaks and abnormalities is required.

FUEL AND OIL

IMPORTANT: When operating a Mercury Marine engine on gasoline containing alcohol, storage of gasoline in the fuel tank for long periods should be avoided. Long periods of storage, common to boats, create unique problems. In cars, alcohol-blend fuels normally are consumed before they can absorb enough moisture to cause trouble, but boats often sit idle long enough for phase separation to take place. In addition, internal corrosion may take place during storage if alcohol has washed protective oil films from internal components.

Low Permeation Fuel Hose Requirement

Required for outboards manufactured for sale, sold, or offered for sale in the United States.

- The Environmental Protection Agency (EPA) requires that any outboard manufactured after January 1, 2009 must use low permeation fuel hose for the primary fuel hose connecting the fuel tank to the outboard.
- Low permeation hose is USCG Type B1-15 or Type A1-15, defined as not exceeding $15/\text{gm}^2/24 \text{ h}$ with CE 10 fuel at $23 \text{ }^\circ\text{C}$ as specified in SAE J 1527 - marine fuel hose.

Filling Fuel Tank

WARNING

Avoid serious injury or death from a gasoline fire or explosion. Use caution when filling fuel tanks. Always stop the engine and do not smoke or allow open flames or sparks in the area while filling fuel tanks.

Fill fuel tanks outdoors away from heat, sparks, and open flames.

Remove portable fuel tanks from boat to refill them.

Always stop engine before refilling tanks.

Do not completely fill the fuel tanks. Leave approximately 10% of the tank volume unfilled. Fuel will expand in volume as its temperature rises and can leak under pressure if the tank is completely filled.

FUEL AND OIL

PORTABLE FUEL TANK PLACEMENT IN THE BOAT

Place the fuel tank in the boat so the vent is higher than the fuel level under normal boat operating conditions.

Engine Oil Recommendations

Mercury Verado NMMA FC-W certified synthetic blend 25W-50 multi-viscosity 4-Stroke Outboard Oil is recommended for general, all-temperature use. As an optional choice, Mercury or Quicksilver NMMA FC-W certified synthetic 25W-40 multi-viscosity 4-Stroke Outboard Oil may be used. If the recommended Mercury or Quicksilver NMMA FC-W certified oils are not available, a major brand of NMMA FC-W certified 4-Stroke Outboard Oil of similar viscosity may be used.

IMPORTANT: The use of non-detergent oils, multi-viscosity oils (other than Mercury or Quicksilver NMMA FC-W certified oil or a major brand NMMA FC-W certified oil), synthetic oils, low quality oils, or oils that contain solid additives are not recommended.

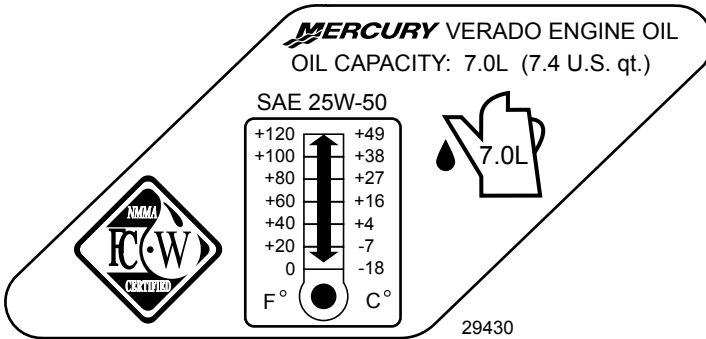

Checking and Adding Engine Oil

IMPORTANT: Do not overfill. Tilt outboard out/up past vertical for approximately one minute to allow trapped oil to drain back to the oil sump. Tilt outboard to vertical (not tilted) position when checking engine oil. For accurate readings, check oil only when engine is cold or after engine has not run for at least an hour.

1. Before starting (cold engine) tilt outboard out/up past vertical to allow trapped oil to drain back to the oil sump. Allow outboard to remain tilted for approximately one minute.

FUEL AND OIL

2. Tilt outboard to vertical operating position.
 3. Remove the top cowl. Refer to **Maintenance - Cowl Removal and Installation**.
 4. Pull out the dipstick. Wipe the dipstick end with a clean rag or towel and push it back in all the way.
 5. Pull the dipstick back out again and observe the oil level. Oil should be in the operating range (cross hatched region).
- IMPORTANT:** Do not try to fill the oil level to the top of the operating range (cross hatched region). Oil level is correct as long as it appears in the operating range (cross hatched region).

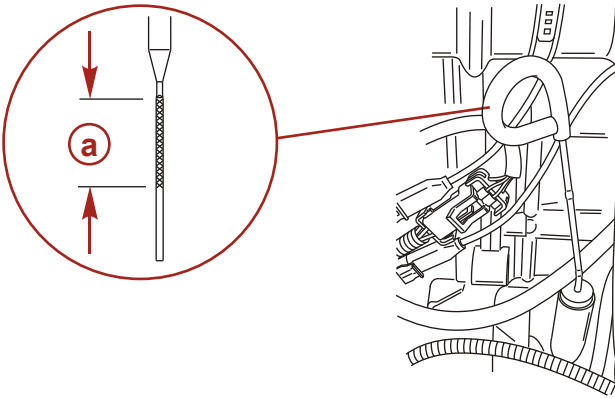

15730

a - Oil level operating range

FUEL AND OIL

6. If the oil level is below the operating range (cross hatched region), remove the oil filler cap and add approximately 500 ml (16 oz) of specified outboard motor oil. Allow a few minutes for the added oil to drain to the oil sump and recheck the dipstick. Repeat the process until oil level is on the operating range (cross hatched region). Do not try to fill to the upper end of the operation range (cross hatched region).

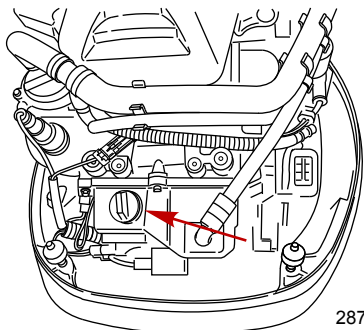

IMPORTANT: Inspect oil for signs of contamination. Oil contaminated with water will have a milky color to it; oil contaminated with fuel will have a strong fuel smell. If contaminated oil is noticed, have the engine checked by your dealer.

7. Push the dipstick back in all the way.
8. Reinstall the oil fill cap hand tight.
9. Reinstall top cowl.

FEATURES AND CONTROLS

Panel Mount Control Features and Operation

1. Operation of shift and throttle is controlled by the movement of the control handle. Push the control handle forward from neutral to the first detent for forward gear. Continue pushing forward to increase speed. Pull the control handle back from neutral to the first detent for reverse gear. Continue pulling back to increase speed.

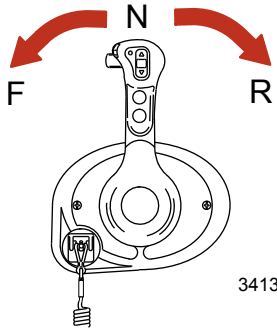

2. Shift lock - Pressing the shift lock allows the engine to shift. The shift lock must always be pressed when moving the control handle out of the neutral position.

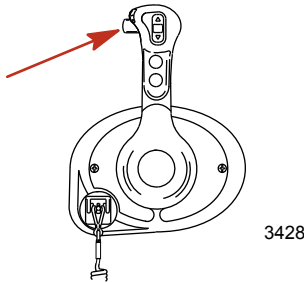

FEATURES AND CONTROLS

3. Trim switch (if equipped) - Pressing the trim switch allows the engine to trim up or down.

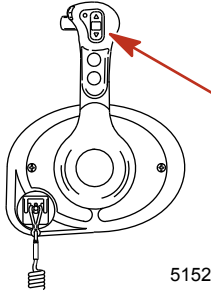

5152

4. Throttle only button - Allows the boat operator to increase engine RPM for warm-up, without shifting the engine into gear. To engage throttle only, move the control handle into the neutral position. Press the throttle only button while moving the control handle ahead to the forward detent. The horn indicates throttle only is engaged. Advance throttle to increase engine RPM. To disengage, return control handle to neutral position. Engine RPM is limited to prevent engine damage.

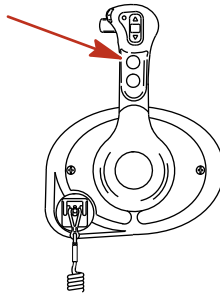

3416

FEATURES AND CONTROLS

5. Stop/start button - Allows the boat operator to start or stop the engine without using the ignition key. The ignition key must be in the "ON" position to start the engine.

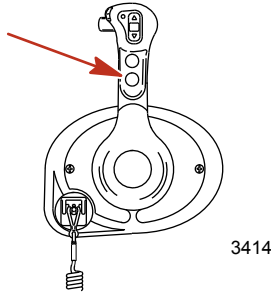

6. Lanyard stop switch - Turns the ignition off whenever the operator (when attached to the lanyard) moves far enough away from the operator's position to activate the switch.

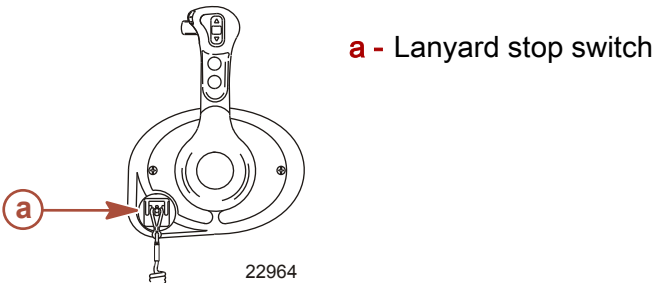

7. Control handle tension adjustment screw - This screw can be adjusted to increase or decrease the tension on the control handle (cover must be removed). This will help prevent unwanted motion of the handle in rough water. Turn screw clockwise to increase tension and counterclockwise to decrease tension. Adjust to tension desired.

FEATURES AND CONTROLS

8. Detent tension adjustment screw - This screw can be adjusted to increase or decrease the effort to move control handle out of detent positions (cover must be removed). Turning screw clockwise will increase tension. Adjust to tension desired.

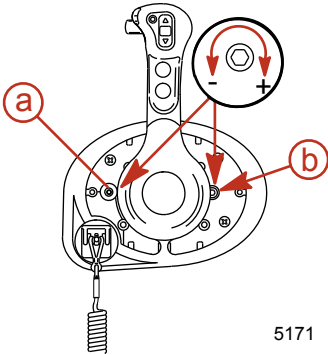

a - Detent tension adjustment screw

b - Control handle tension adjustment screw

5171

Single Handle Console Control Features and Operation

1. Operation of shift and throttle is controlled by the movement of the control handle. Push the control handle forward from neutral to the first detent for forward gear. Continue pushing forward to increase speed. Pull the control handle back from neutral to the first detent for reverse gear. Continue pushing back to increase speed.

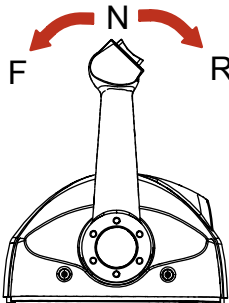

3417

FEATURES AND CONTROLS

- Trim switch (if equipped) - Pressing the trim switch allows the engine to trim up or down.

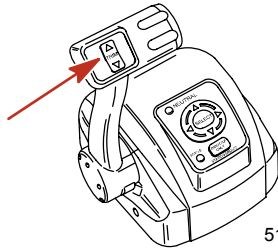

5185

- Control handle tension adjustment screw - This screw can be adjusted to increase or decrease the tension on the control handle (cover must be removed). This will help prevent unwanted motion of the remote control handle in rough water. Turn the screw clockwise to increase tension and counterclockwise to decrease tension. Adjust to the desired tension.
- Detent tension adjustment screw - This screw can be adjusted to increase or decrease the effort to move control handle out of detent positions (cover must be removed). Turning the screw clockwise will increase tension. Adjust to the desired tension.

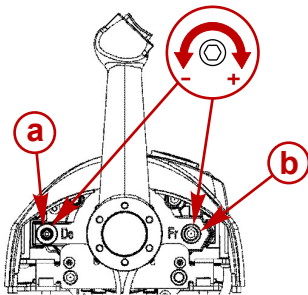

28556

- a** - Detent tension adjustment screw
- b** - Control handle tension adjustment screw

- Arrow trackpad - Navigates through the System View on-screen function messages.

FEATURES AND CONTROLS

6. Select button - Selects the System View on-screen options and confirm data entries. Holding the select button for two seconds will pause the slide show if selected in Favorites. Holding the select button for three seconds will activate the reset data function (except when in the slide show function). Holding the select button for five seconds or more will bring up the Home page.
7. Neutral LED - The neutral LED illuminates when engine is in neutral gear position. It also flashes when throttle only is activated.

NOTE: Gear position is determined by sensing the position of the shift actuator on the engine, not the position of the control handle.

8. Active LED - The active LED illuminates to show the remote control is active and ready for use.
9. Throttle only/station select button - Allows the boat operator to increase engine RPM for warm-up, without shifting the engine into gear. To engage throttle only, move the control handle into the neutral position. Press the throttle only button while moving the control handle ahead to the forward detent. The horn will sound once and the neutral light will start flashing. The horn will sound twice when throttle only is engaged. Advance throttle to increase engine RPM. To disengage, return control handle to neutral position and press the throttle only button. Engine RPM is limited to prevent engine damage. Pressing the station select button at an inactive helm initiates a helm transfer. Refer to **Helm Transfer**.

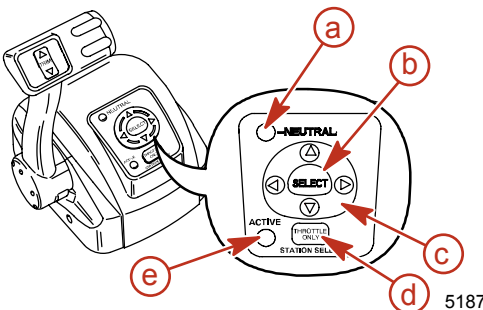

- a - Neutral LED
- b - Select button
- c - Arrow trackpad
- d - Throttle only/
station select
button
- e - Active LED

FEATURES AND CONTROLS

HELM TRANSFER

WARNING

Avoid serious injury or death from loss of boat control. The boat operator should never leave the active station while engine is in gear. Helm transfer should only be attempted while both stations are manned. One-person helm transfer should only be performed while engine is in neutral.

***NOTE:** Idle position is preferred when doing a helm transfer. If conditions do not allow the remote control to be placed at idle position, a helm transfer can be done while in gear.*

***NOTE:** The active light on the remote control will be illuminated at the helm that is in control of the engine.*

The helm transfer function allows the boat operator to select which helm is in control of engine operation. Pressing the throttle only/station select button two times allows engine control to be transferred to a new helm. When a helm transfer is initiated, the control will automatically start adjusting engine RPM and gear position to match the control handle setting at the new helm. Adjust the control handles to the desired throttle and gear position.

***NOTE:** There is a 10 second time frame to complete a helm transfer. If the helm transfer is not completed, the action will be cancelled and a double beep will sound. Pressing the throttle only/station select button again will reinitiate a helm transfer.*

1. Place active remote control lever to idle position.
2. Proceed to the inactive helm and position remote control lever to the idle position.

FEATURES AND CONTROLS

3. Press throttle only/station select button two times. The "ACTIVE" light will illuminate to indicate the remote control is in control of the engine.

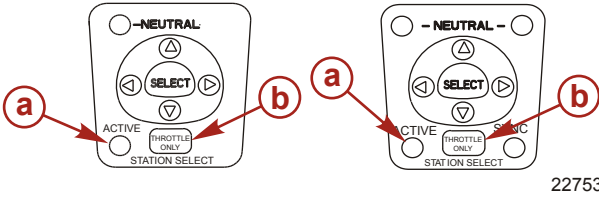

- a** - Active light
- b** - Throttle only/station select button

4. The "ACTIVE" light will switch off at the original helm.

Synchronizing Helms Prior to Helm Transfer

Pressing the throttle only/station select button one time allows the boat operator 10 seconds to match up the control handle setting at the new station with the handle setting that is at the old (to be inactive) station. If the handle is not matched, the neutral light will flash. The light blinks faster as the handle is nearing match position. Once the light stays on continuously, the handle is matched and the throttle only/station select button can be pressed again to complete the transfer. This completes the transfer process, and give control to the new station. If the helm transfer is not completed within 10 seconds, the helm transfer is cancelled.

FEATURES AND CONTROLS

Slim Binnacle Control Features and Operation

1. Operation of shift and throttle is controlled by the movement of the control handle. Push the control handle forward from neutral to the first detent for forward gear. Continue pushing forward to increase speed. Pull the control handle back from neutral to the first detent for reverse gear. Continue pushing back to increase speed.

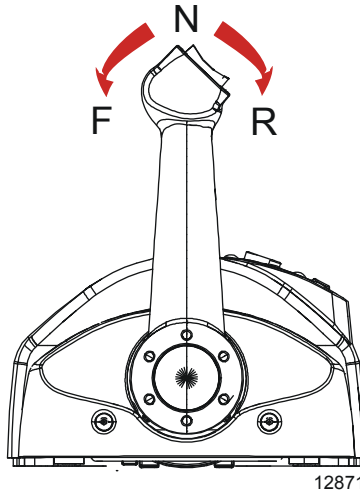

2. Trim switch (if equipped) - Pressing the trim switch allows the engine to trim up or down.

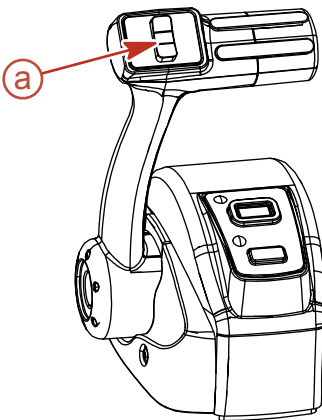

a - Trim switch

12874

FEATURES AND CONTROLS

- Control handle tension adjustment screw - This screw can be adjusted to increase or decrease the tension on the control handle (cover must be removed). This will help prevent unwanted motion of the remote control handle in rough water. Turn the screw clockwise to increase tension and counterclockwise to decrease tension. Adjust to the desired tension.
- Detent tension adjustment screw - This screw can be adjusted to increase or decrease the effort to move control handle out of detent positions (cover must be removed). Turning the screw clockwise will increase tension. Adjust to the desired tension.

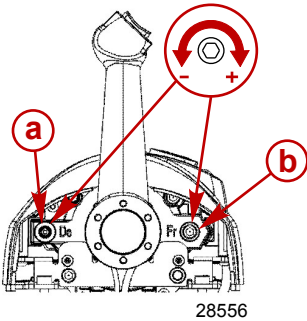

- a** - Detent tension adjustment screw
- b** - Control handle tension adjustment screw

- Start/stop button - Allows the boat operator to start or stop the engine without using the ignition key.
- Neutral LED - The neutral LED illuminates when engine is in neutral gear position. It also flashes when throttle only is activated.

NOTE: Gear position is determined by sensing the position of the shift actuator on the engine, not the position of the control handle.

- Active LED - The active LED illuminates to show the remote control is active and ready for use.

FEATURES AND CONTROLS

8. Throttle only/station select button - Allows the boat operator to increase engine RPM for warm-up, without shifting the engine into gear. To engage throttle only, move the control handle into the neutral position. Press the throttle only button while moving the control handle ahead to the forward detent. The horn will sound once and the neutral light will start flashing. The horn will sound twice when throttle only is engaged. Advance throttle to increase engine RPM. To disengage, return control handle to neutral position and press the throttle only button. Engine RPM is limited to prevent engine damage. Pressing the station select button at an inactive helm initiates a helm transfer. Refer to **Helm Transfer**.

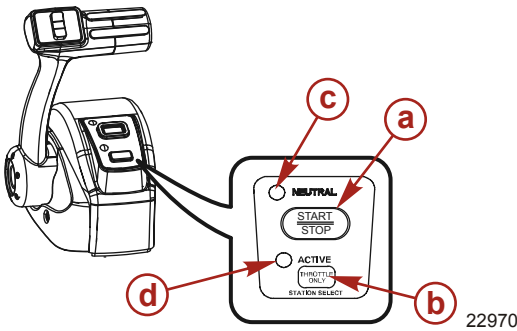

- a - Start/stop button
- b - Throttle only/
station select
button
- c - Neutral LED
- d - Active LED

HELM TRANSFER

WARNING

Avoid serious injury or death from loss of boat control. The boat operator should never leave the active station while engine is in gear. Helm transfer should only be attempted while both stations are manned. One-person helm transfer should only be performed while engine is in neutral.

NOTE: Idle position is preferred when doing a helm transfer. If conditions do not allow the remote control to be placed at idle position, a helm transfer can be done while in gear.

NOTE: The active light on the remote control will be illuminated at the helm that is in control of the engine.

FEATURES AND CONTROLS

The helm transfer function allows the boat operator to select which helm is in control of engine operation. Pressing the throttle only/station select button two times allows engine control to be transferred to a new helm. When a helm transfer is initiated, the control will automatically start adjusting engine RPM and gear position to match the control handle setting at the new helm. Adjust the control handles to the desired throttle and gear position.

NOTE: *There is a 10 second time frame to complete a helm transfer. If the helm transfer is not completed, the action will be cancelled and a double beep will sound. Pressing the throttle only/station select button again will reinitiate a helm transfer.*

1. Place the active remote control lever to idle position.
2. Proceed to the inactive helm and position remote control lever to the idle position.
3. Press throttle only/station select button two times. The "ACTIVE" light will illuminate to indicate the remote control is in control of the engine.

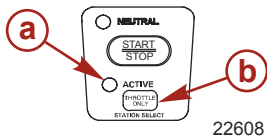

- a - Active light
- b - Throttle only/station select button

4. The "ACTIVE" light will switch off at the original helm.

Synchronizing Helms Prior to Helm Transfer

Pressing the throttle only/station select button one time allows the boat operator 10 seconds to match up the control handle setting at the new station with the handle setting that is at the old (to be inactive) station. If the handle is not matched, the neutral light will flash. The light blinks faster as the handle is nearing match position. Once the light stays on continuously, the handle is matched and the throttle only/station select button can be pressed again to complete the transfer. This completes the transfer process, and gives control to the new station. If the helm transfer is not completed within 10 seconds, the helm transfer is cancelled.

FEATURES AND CONTROLS

Dual Handle Console Control Features and Operation

1. Operation of shift and throttle is controlled by the movement of the control handle. Push the control handle forward from neutral to the first detent for forward gear. Continue pushing forward to increase speed. Pull the control handle back from neutral to the first detent for reverse gear. Continue pulling back to increase speed.

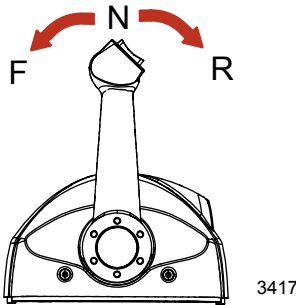

2. Trim switch (if equipped) - Pressing the trim switch allows the engine to trim up or down.

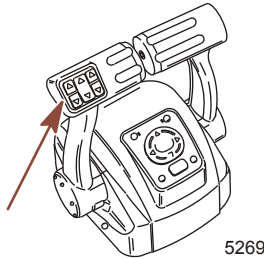

3. Control handle tension adjustment screw - This screw can be adjusted to increase or decrease the tension on the control handle (cover must be removed). This will help prevent unwanted motion of the handle in rough water. Turn the screw clockwise to increase tension and counterclockwise to decrease tension. Adjust to the desired tension.

FEATURES AND CONTROLS

4. Detent tension adjustment screw - This screw can be adjusted to increase or decrease the effort to move control handle out of detent positions (cover must be removed). Turning screw clockwise will increase tension. Adjust to the desired tension.

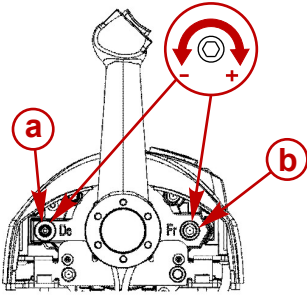

a - Detent tension adjustment screw

b - Control handle friction adjustment screw

28556

5. Throttle only/station select button - Allows the boat operator to increase engine RPM for warm-up, without shifting the engine into gear. To engage throttle only, move the control handle into the neutral position. Press the throttle only button while moving the control handle ahead to the forward detent. The horn will sound once and the neutral light will start flashing. The horn will sound twice when throttle only is engaged. Advance throttle to increase engine RPM. To disengage, return control handle to neutral position and press the throttle only button. Engine RPM is limited to prevent engine damage. Pressing the station select button at an inactive helm initiates a helm transfer. Refer to **Helm Transfer**.
6. Arrow trackpad - Navigates through System View on-screen function messages.
7. Select button - Selects System View on-screen options and confirms data entries. Holding the select button for two seconds will pause the slide show if selected in Favorites. Holding the select button for three seconds will activate the reset data function (except when in the slide show function). Holding the select button for five seconds or more will bring up the Home page.

FEATURES AND CONTROLS

8. Neutral LEDs - The neutral LEDs illuminate when engines are in neutral gear position. The lights will flash when in throttle only mode.

NOTE: Gear position is determined by sensing the position of the shift actuator on the engine, not the position of the control handle.

9. Active LED - The active LED illuminates to show the remote control is active and ready for use.

10. Sync LED - The sync LED illuminates when the RPM of the two engines are being synchronized by the DTS system.

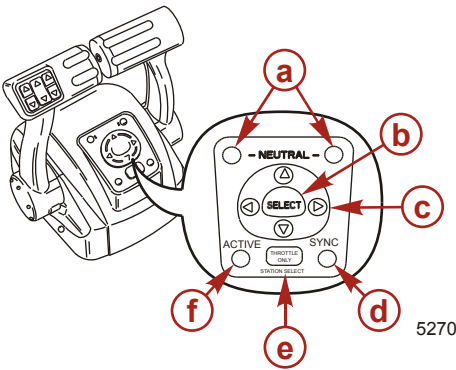

- a - Neutral LEDs
- b - Select button
- c - Arrow trackpad
- d - Sync LED
- e - Throttle only/station select button
- f - Active LED

SYNCHRONIZING ENGINES

The auto synchronizing feature, when engaged, will automatically adjust all engine speeds to match the speed of the starboard engine.

FEATURES AND CONTROLS

Engine auto synchronization will automatically engage when engine speed is over 900 RPM for two seconds and remote control handles are positioned within 10% of each other. The "SYNC" light will turn on when the engines are synchronized. Auto synchronization will stay engaged up to 95% throttle opening. To disengage, move one or both control handles until they are more than 10% apart, reduce engine speed below 900 RPM, or increase engine speed beyond 95%.

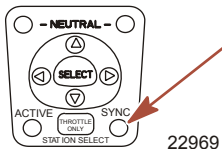

HELM TRANSFER

WARNING

Avoid serious injury or death from loss of boat control. The boat operator should never leave the active station while engine is in gear. Helm transfer should only be attempted while both stations are manned. One-person helm transfer should only be performed while engine is in neutral.

NOTE: Idle position is preferred when doing a helm transfer. If conditions do not allow the remote control to be placed at idle position, a helm transfer can be done while in gear.

NOTE: The active light on the remote control will be illuminated at the helm that is in control of the engine.

The helm transfer function allows the boat operator to select which helm is in control of engine operation. Pressing the throttle only/station select button two times allows engine control to be transferred to a new helm. When a helm transfer is initiated, the control will automatically start adjusting engine RPM and gear position to match the control handle setting at the new helm. Adjust the control handles to the desired throttle and gear position.

FEATURES AND CONTROLS

NOTE: There is a 10 second time frame to complete a helm transfer. If the helm transfer is not completed, the action will be cancelled and a double beep will sound. Pressing the throttle only/station select button again will reinitiate a helm transfer.

1. Place active remote control lever to idle position.
2. Proceed to the inactive helm and position remote control lever to the idle position.
3. Press throttle only/station select button two times. The "ACTIVE" light will illuminate to indicate the remote control is in control of the engine.

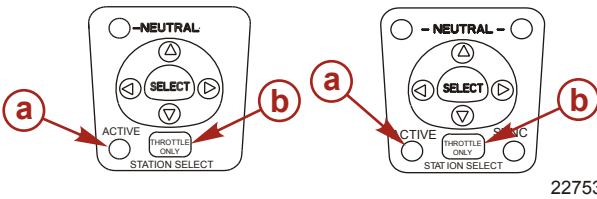

22753

a - Active light

b - Throttle only/station select button

4. The "ACTIVE" light will switch off at the original helm.

Synchronizing Helms Prior to Helm Transfer

Pressing the throttle only/station select button one time allows the boat operator 10 seconds to match up the control handle setting at the new station with the handle setting that is at the old (to be inactive) station. If the handle is not matched, the neutral light will flash. The light blinks faster as the handle is nearing match position. Once the light stays on continuously, the handle is matched and the throttle only/station select button can be pressed again to complete the transfer. This completes the transfer process, and give control to the new station. If the helm transfer is not completed within 10 seconds, the helm transfer is cancelled.

FEATURES AND CONTROLS

Dual Handle Console Control with CAN Trackpad Features and Operation

DUAL-HANDLE CONSOLE CONTROL WITH CAN TRACKPAD: FEATURES AND OPERATION

1. Operation of shift and throttle is controlled by the movement of the control handle. Push the control handle forward from neutral to the first detent for forward gear. Continue pushing the handle forward to increase speed. Pull the control handle back from neutral to the first detent for reverse gear. Continue pulling the handle back to increase speed.

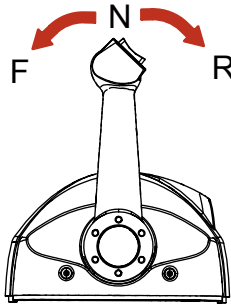

3417

2. Trim switch (if equipped) - Pressing the trim switch allows the engine to trim up and down.

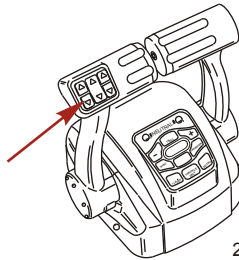

22132

3. Neutral lights - The neutral lights illuminate when the engine is in neutral gear position. The lights will flash when the engine is in throttle only mode.

NOTE: Gear position is determined by the position of the shift actuator on the engine, not the position of the control handle.

FEATURES AND CONTROLS

4. Troll button - Pressing the "TROLL" button activates troll control. The troll control feature allows the boat operator to set the engine speed for slow speed cruising or maneuvering. To activate, move the control handles into forward detent and press the button. Use the - or + buttons to decrease or increase speed, up to a maximum of 1000 RPM. If troll control is set at a desired speed and then shut off, the system remembers the set speed and will return to that speed when reengaged. To turn off the troll control press the "TROLL" button, move the throttle to a different speed, or shift the engine into neutral.
5. Transfer button - Pressing the "TRANSFER" button allows engine operation to be transferred from a different helm. Refer to **Helm Transfer**.
6. Dock button - Pressing the "DOCK" button initiates docking mode. Docking mode reduces throttle capacity to approximately 50% of normal throttle. To turn off docking mode, shift the engine into neutral and press the "DOCK" button.
7. Throttle only button - Allows the boat operator to increase engine RPM for warm-up, without shifting the engine into gear. To engage throttle only, move the control handle into the neutral position. Press the throttle only button and move the control handle ahead to the forward detent. The horn will sound once and the neutral light will start flashing. The horn will sound twice when throttle only is engaged. Advance throttle to increase engine RPM. To disengage, return control handle to neutral position and press the throttle only button. Engine RPM is limited to prevent engine damage.
8. 1 lever button - Pressing the "1 LEVER" button initiates single lever mode. Single lever mode enables the throttle and shift functions of both engines to be controlled by the port control handle. To turn off single lever mode, shift the engine into neutral and press the "1 LEVER" button.

FEATURES AND CONTROLS

9. Sync button - Pressing the "SYNC" button turns off or on the auto synchronization feature. Refer to **Synchronizing Engines**.

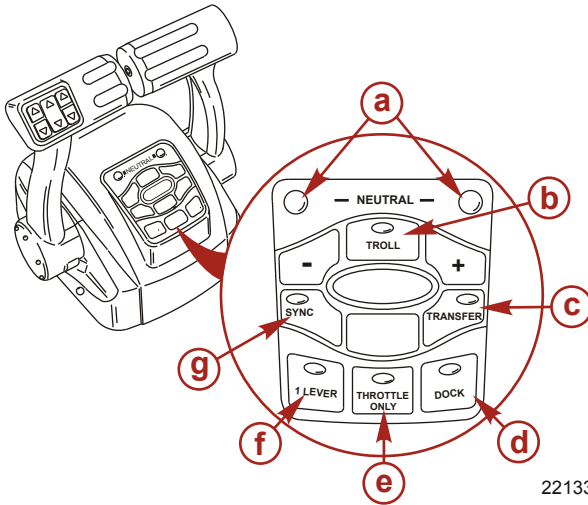

22133

- a - Neutral LEDS
- b - Troll button
- c - Transfer button
- d - Dock button
- e - Throttle only
- f - 1 lever button
- g - Sync button

10. Control handle tension adjustment screw - This screw can be adjusted to increase or decrease the tension on the control handle (cover must be removed). This will help prevent unwanted motion of the handle in rough water. Turn the screw clockwise to increase tension and counterclockwise to decrease tension. Adjust to tension desired.

FEATURES AND CONTROLS

11. Detent tension adjustment screw - This screw can be adjusted to increase or decrease the effort to move control handle out of detent positions (cover must be removed). Turning the screw clockwise will increase tension. Adjust to tension desired.

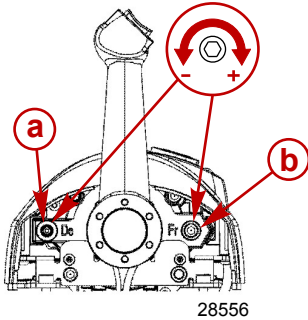

a - Detent tension adjustment screw

b - Control handle tension adjustment screw

28556

SYNCHRONIZING ENGINES

The auto synchronizing feature, when engaged, will automatically adjust all engine speeds to match the speed of the starboard engine.

Press the "SYNC" button on the CAN trackpad to turn auto synchronization on or off. When the sync LED is yellow, the "SYNC" button has been pressed, but the conditions are not right for auto synchronization to engage. When the sync LED turns red, engine synchronization has been engaged. The engines will remain synchronized as long as engine speed is over 900 RPM for two seconds, remote control handles are positioned within 10% of each other, and the engines are below 95% throttle opening.

To disengage the auto synchronization feature, press the "SYNC" button.

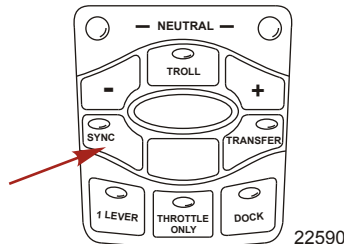

22590

FEATURES AND CONTROLS

HELM TRANSFER

WARNING

Avoid serious injury or death from loss of boat control. The boat operator should never leave the active station while engine is in gear. Helm transfer should only be attempted while both stations are manned. One-person helm transfer should only be performed while engine is in neutral.

NOTE: Neutral position is preferred when doing a station transfer. If conditions do not allow the remote control to be placed in the neutral position, a helm transfer can be done while in gear.

The helm transfer function allows the boat operator to select which helm is in control of engine operation. Pressing the "TRANSFER" button two times allows engine control to be transferred to a new helm. When a helm transfer is initiated, the control will automatically start adjusting engine RPM and gear position to match the control handle setting at the new helm. Adjust the control handles to the desired throttle and gear position.

Once the "TRANSFER" button is pressed, the transfer LED will light up and one beep will sound. Press the "TRANSFER" button again to complete the helm transformation. When helm transformation is complete, another beep will sound and the transfer LED will turn off.

NOTE: There is a 10 second time frame to complete a helm transfer. If the helm transfer is not completed, the action will be cancelled and a double beep will sound. Pressing the "TRANSFER" button again will reinitiate a helm transfer.

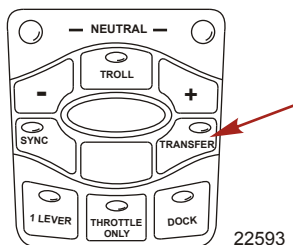

FEATURES AND CONTROLS

Synchronizing Helms Prior to Transfer

Pressing the "TRANSFER" button allows the boat operator 10 seconds to match up the control handle settings at the new helm with the handle settings that are at the old (to be inactive) helm. If the handles are not matched, the neutral lights will flash. The light blinks faster as the handles are nearing match position. Once the light stays on continuously, the handles are matched and the button can be pressed again to complete the transfer. This completes the transfer process, and gives control to the new station. If the helm transfer is not completed within 10 seconds, the action will be cancelled.

Shadow Mode Control Features and Operation

TRIPLE ENGINE THROTTLE AND SHIFT OPERATION

Movement of the handles on the remote control allows the boat operator to control the engine throttle speed and gear shift positions of all three engines.

The throttle and shift function is dependant on what engines are running. Refer to the following table.

Port Engine	Center Engine	Starboard Engine	Control Handle Function
Running	Running	Running	Port engine throttle and shift = controlled by port control handle
			Starboard engine throttle and shift = controlled by starboard control handle
			Center engine throttle = average of port and starboard engines
			Center engine shift = neutral unless both engines are in the same gear
Running	Running	Off	Port and center engine throttle and shift = controlled by port control handle
Off	Running	Running	Starboard and center engine throttle and shift = controlled by starboard control handle

FEATURES AND CONTROLS

Port Engine	Center Engine	Starboard Engine	Control Handle Function
Running	Off	Running	Port engine throttle and shift = controlled by port control handle
			Starboard engine throttle and shift = controlled by starboard control handle
Running	Off	Off	Port engine throttle and shift = controlled by port control handle
Off	Off	Running	Starboard engine throttle and shift = controlled by starboard control handle
Off (ignition key switch turned on)	Running	Off (ignition key switch turned on)	Center engine throttle and shift = neutral/idle unless both control handles are in the same gear

Turning off one of the outer engines while underway will cause the center engine to go into forced neutral/idle. Operation to the center engine can be restored by moving the control handle of the functioning outer engine back into neutral position and then reengaging. The center engine speed and gear shift will then be controlled by the functioning outer engine.

Turning off the center engine while underway will have no effect on the operation of the outer engines.

If a failure should occur while underway which causes one of the outer engines into forced neutral/idle condition, the center engine will also be forced to neutral/idle. Operation to the center engine can be restored by moving the control handle of the functioning outer engine back into neutral and then reengaging.

QUAD ENGINE THROTTLE AND SHIFT OPERATION

Movement of the handles on the remote control allows the boat operator to control the engine throttle speed and gear shift positions of all four engines.

The throttle and shift function is dependent on what engines are running. Refer to the following table.

FEATURES AND CONTROLS

Port Outer Engine	Port Inner Engine	Starboard Inner Engine	Starboard Outer Engine	Control Handle Function
Running	Running	Running	Running	Port inner and outer engines throttle and shift = controlled by port control handle
				Starboard inner and outer engines throttle and shift = controlled by starboard control handle
Running	Running	Off	Off	Port inner and outer engine throttle and shift = controlled by port control handle
Off	Off	Running	Running	Starboard inner and outer engine throttle and shift = controlled by starboard control handle
Off (ignition key switch turned on)	Running	Running	Running	Port inner engine throttle and shift = controlled by port control handle
Running	Running	Running	Off (ignition key switch turned on)	Starboard inner engine throttle and shift = controlled by starboard control handle
Off (ignition key switch turned off)	Running	Running	Running	Port inner engine throttle and shift = controlled by starboard control handle
Running	Running	Running	Off (ignition key switch turned off)	Starboard inner engine throttle and shift = controlled by port control handle

FEATURES AND CONTROLS

Port Outer Engine	Port Inner Engine	Starboard Inner Engine	Starboard Outer Engine	Control Handle Function
Running	Off	Off	Running	Port outer engine throttle and shift = controlled by port control handle
				Starboard outer engine throttle and shift = controlled by starboard control handle
Off (ignition key switch turned on)	Running	Running	Off (ignition key switch turned on)	Port inner engine throttle and shift = controlled by port control handle
				Starboard inner engine throttle and shift = controlled by starboard control handle

Turning off the starboard outer engine while underway will cause the starboard inner engine to go into forced neutral/idle. Operation to the inner engine can be restored by turning the starboard outer engine ignition key to the on position and moving the starboard control handle back into neutral position and then reengaging. The inner engine speed and gear shift will then be controlled by the starboard control handle.

Turning off the port outer engine while underway will cause the port inner engine to go into forced neutral/idle. Operation to the inner engine can be restored by turning the port outer engine ignition key to the on position and moving the port control handle back into neutral position and then reengaging. The inner engine speed and gear shift will then be controlled by the port control handle.

Turning off one of the inner engines while underway will have no effect on the operation of the outer engines.

FEATURES AND CONTROLS

If a failure should occur while underway which causes the starboard outer engines into forced neutral/idle condition, the inner starboard engine will also be forced to neutral/idle.

Operation to the inner engine can be restored by moving the starboard control handle back into neutral and then reengaging.

If a failure should occur while underway which causes the port outer engines into forced neutral/idle condition, the inner port engine will also be forced to neutral/idle. Operation to the inner engine can be restored by moving the port control handle back into neutral and then reengaging.

TRIM SWITCH AND KEY PAD FEATURES

1. Trim switch (if equipped) - Operates the trim for all engines. An accessory trim switch panel is required for trimming engines individually.

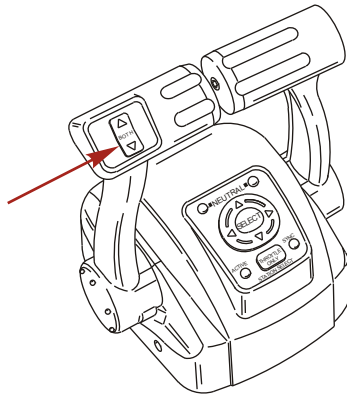

13853

FEATURES AND CONTROLS

2. Throttle only/station select button - Allows the boat operator to increase engine RPM for warm-up, without shifting the engine into gear. To engage throttle only, move the control handle into the neutral position. Press the throttle only button while moving the control handle ahead to the forward detent. The horn will sound once and the neutral light will start flashing. The horn will sound twice when throttle only is engaged. Advance throttle to increase engine RPM. To disengage, return control handle to neutral position and press the throttle only button. Engine RPM is limited to prevent engine damage. Pressing the station select button at an inactive helm initiates a helm transfer. Refer to **Helm Transfer**.
3. Arrow trackpad - Navigates through System View on-screen function messages.
4. Select button - Selects System View on-screen options and confirm data entries. Holding the select button for two seconds will pause the slide show if selected in Favorites. Holding the select button for three seconds will activate the reset data function (except when in the slide show function). Holding the select button for five seconds or more will bring up the Home page.
5. Neutral LEDs - The neutral LEDs illuminate when engines are in neutral gear position. The lights will flash when in throttle only mode.

NOTE: *Gear position is determined by sensing the position of the shift actuator on the engine, not the position of the control handle.*

6. Active LED - The active LED illuminates to show the remote control is active and ready for use.

FEATURES AND CONTROLS

7. Sync LED - The "SYNC" LED illuminates when the RPM of the engines are being synchronized by the DTS system.

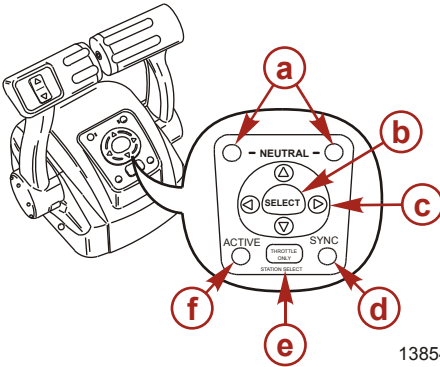

- a - Neutral LEDs
- b - Select button
- c - Arrow trackpad
- d - Sync LED
- e - Throttle only/station select button
- f - Active LED

13854

SYNCHRONIZING ENGINES

The auto synchronizing feature, when engaged, will automatically adjust all engine speeds to match the speed of the starboard engine.

Engine auto synchronization will automatically engage when engine speed is over 900 RPM for two seconds and remote control handles are positioned within 10% of each other. The "SYNC" light will turn on when the engines are synchronized. Auto synchronization will stay engaged up to 95% throttle opening. To disengage, move one or both control handles until they are more than 10% apart, reduce engine speed below 900 RPM, or increase engine speed beyond 95%.

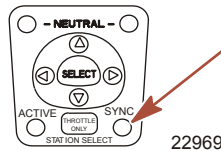

22969

FEATURES AND CONTROLS

HELM TRANSFER

WARNING

Avoid serious injury or death from loss of boat control. The boat operator should never leave the active station while engine is in gear. Helm transfer should only be attempted while both stations are manned. One-person helm transfer should only be performed while engine is in neutral.

NOTE: *Idle position is preferred when doing a helm transfer. If conditions do not allow the remote control to be placed at idle position, a helm transfer can be done while in gear.*

NOTE: *The active light on the remote control will be illuminated at the helm that is in control of the engine.*

The helm transfer function allows the boat operator to select which helm is in control of engine operation. Pressing the throttle only/station select button two times allows engine control to be transferred to a new helm. When a helm transfer is initiated, the control will automatically start adjusting engine RPM and gear position to match the control handle setting at the new helm. Adjust the control handles to the desired throttle and gear position.

NOTE: *There is a 10 second time frame to complete a helm transfer. If the helm transfer is not completed, the action will be cancelled and a double beep will sound. Pressing the throttle only/station select button again will reinitiate a helm transfer.*

1. Place active remote control lever to idle position.
2. Proceed to the inactive helm and position remote control lever to the idle position.

FEATURES AND CONTROLS

3. Press throttle only/station select button two times. The "ACTIVE" light will illuminate to indicate the remote control is in control of the engine.

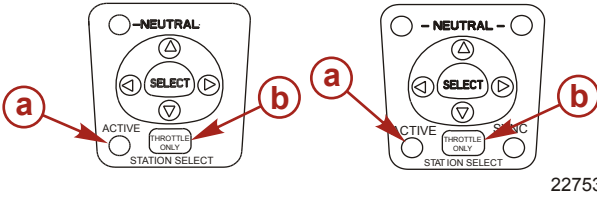

a - Active light

b - Throttle only/station select button

4. The "ACTIVE" light will switch off at the original helm.

Synchronizing Helms Prior to Helm Transfer

Pressing the throttle only/station select button one time allows the boat operator 10 seconds to match up the control handle setting at the new station with the handle setting that is at the old (to be inactive) station. If the handle is not matched, the neutral light will flash. The light blinks faster as the handle is nearing match position. Once the light stays on continuously, the handle is matched and the throttle only/station select button can be pressed again to complete the transfer. This completes the transfer process, and give control to the new station. If the helm transfer is not completed within 10 seconds, the helm transfer is cancelled.

Shadow Mode Control with CAN Trackpad Features and Operation

TRIPLE ENGINE THROTTLE AND SHIFT OPERATION

Movement of the handles on the remote control allows the boat operator to control the engine throttle speed and gear shift positions of all three engines.

The throttle and shift function is dependant on what engines are running. Refer to the following table.

FEATURES AND CONTROLS

Port Engine	Center Engine	Starboard Engine	Control Handle Function
Running	Running	Running	Port engine throttle and shift = controlled by port control handle
			Starboard engine throttle and shift = controlled by starboard control handle
			Center engine throttle = average of port and starboard engines
			Center engine shift = neutral unless both engines are in the same gear
Running	Running	Off	Port and center engine throttle and shift = controlled by port control handle
Off	Running	Running	Starboard and center engine throttle and shift = controlled by starboard control handle
Running	Off	Running	Port engine throttle and shift = controlled by port control handle
			Starboard engine throttle and shift = controlled by starboard control handle
Running	Off	Off	Port engine throttle and shift = controlled by port control handle
Off	Off	Running	Starboard engine throttle and shift = controlled by starboard control handle
Off (ignition key switch turned on)	Running	Off (ignition key switch turned on)	Center engine throttle and shift = neutral/idle unless both control handles are in the same gear

Turning off one of the outer engines while underway will cause the center engine to go into forced neutral/idle. Operation to the center engine can be restored by moving the control handle of the functioning outer engine back into neutral position and then reengaging. The center engine speed and gear shift will then be controlled by the functioning outer engine.

Turning off the center engine while underway will have no effect on the operation of the outer engines.

FEATURES AND CONTROLS

If a failure should occur while underway which causes one of the outer engines into forced neutral/idle condition, the center engine will also be forced to neutral/idle. Operation to the center engine can be restored by moving the control handle of the functioning outer engine back into neutral and then reengaging.

QUAD ENGINE THROTTLE AND SHIFT OPERATION

Movement of the handles on the remote control allows the boat operator to control the engine throttle speed and gear shift positions of all four engines.

The throttle and shift function is dependent on what engines are running. Refer to the following table.

Port Outer Engine	Port Inner Engine	Starboard Inner Engine	Starboard Outer Engine	Control Handle Function
Running	Running	Running	Running	Port inner and outer engines throttle and shift = controlled by port control handle
				Starboard inner and outer engines throttle and shift = controlled by starboard control handle
Running	Running	Off	Off	Port inner and outer engine throttle and shift = controlled by port control handle
Off	Off	Running	Running	Starboard inner and outer engine throttle and shift = controlled by starboard control handle
Off (ignition key switch turned on)	Running	Running	Running	Port inner engine throttle and shift = controlled by port control handle
Running	Running	Running	Off (ignition key switch turned on)	Starboard inner engine throttle and shift = controlled by starboard control handle

FEATURES AND CONTROLS

Port Outer Engine	Port Inner Engine	Starboard Inner Engine	Starboard Outer Engine	Control Handle Function
Off (ignition key switch turned off)	Running	Running	Running	Port inner engine throttle and shift = controlled by starboard control handle
Running	Running	Running	Off (ignition key switch turned off)	Starboard inner engine throttle and shift = controlled by port control handle
Running	Off	Off	Running	Port outer engine throttle and shift = controlled by port control handle
				Starboard outer engine throttle and shift = controlled by starboard control handle
Off (ignition key switch turned on)	Running	Running	Off (ignition key switch turned on)	Port inner engine throttle and shift = controlled by port control handle
				Starboard inner engine throttle and shift = controlled by starboard control handle

Turning off the starboard outer engine while underway will cause the starboard inner engine to go into forced neutral/idle. Operation to the inner engine can be restored by turning the starboard outer engine ignition key to the on position and moving the starboard control handle back into neutral position and then reengaging. The inner engine speed and gear shift will then be controlled by the starboard control handle.

FEATURES AND CONTROLS

Turning off the port outer engine while underway will cause the port inner engine to go into forced neutral/idle. Operation to the inner engine can be restored by turning the port outer engine ignition key to the on position and moving the port control handle back into neutral position and then reengaging. The inner engine speed and gear shift will then be controlled by the port control handle.

Turning off one of the inner engines while underway will have no effect on the operation of the outer engines.

If a failure should occur while underway which causes the starboard outer engines into forced neutral/idle condition, the inner starboard engine will also be forced to neutral/idle. Operation to the inner engine can be restored by moving the starboard control handle back into neutral and then reengaging.

If a failure should occur while underway which causes the port outer engines into forced neutral/idle condition, the inner port engine will also be forced to neutral/idle. Operation to the inner engine can be restored by moving the port control handle back into neutral and then reengaging.

TRIM SWITCH AND KEY PAD FEATURES

1. Trim switch (if equipped) - Operates the trim for all engines. An accessory trim switch panel is required for trimming engines individually.

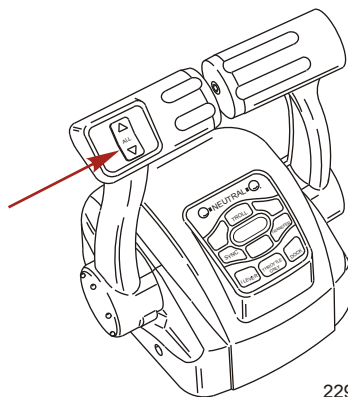

22943

FEATURES AND CONTROLS

2. Neutral lights - The neutral lights illuminate when the engine is in neutral gear position. The lights will flash when the engine is in throttle only mode.

***NOTE:** Gear position is determined by the position of the shift actuator on the engine, not the position of the control handle.*

3. Troll button - Pressing the "TROLL" button activates troll control. The troll control feature allows the boat operator to set the engine speed for slow speed cruising or maneuvering. To activate, move the control handles into forward detent and press the button. Use the - or + buttons to decrease or increase speed, up to the maximum calibrated set point. If troll control is set at a desired speed and then shut off, the system remembers the set speed and will return to that speed when reengaged. To turn off the troll control press the "TROLL" button, move the throttle to a different speed, or shift the engine into neutral.
4. Transfer button - Pressing the "TRANSFER" button allows engine operation to be transferred to a different helm. Refer to **Helm Transfer**.
5. Dock button - Pressing the "DOCK" button initiates docking mode. Docking mode reduces throttle capacity to approximately 50% of normal throttle. To turn off docking mode, shift the engine into neutral and press the "DOCK" button.
6. Throttle only button - Allows the boat operator to increase engine RPM for warm-up, without shifting the engine into gear. To engage throttle only, move the control handle into the neutral position. Press the throttle only button while moving the control handle ahead to the forward detent. The horn will sound once and the neutral light will start flashing. The horn will sound twice when throttle only is engaged. Advance throttle to increase engine RPM. To disengage, return control handle to neutral position and press the throttle only button. Engine RPM is limited to prevent engine damage.

FEATURES AND CONTROLS

- 1 lever button - Pressing the "1 LEVER" button initiates single lever mode. Single lever mode enables the throttle and shift functions of both engines to be controlled by the port control handle. To turn off single lever mode, shift the engine into neutral and press the "1 LEVER" button.
- Sync button - Pressing the "SYNC" button turns off or on the auto synchronization feature. Refer to **Synchronizing Engines**.

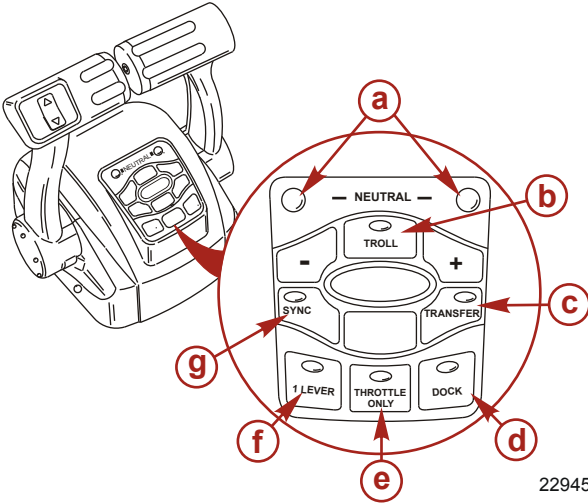

22945

- a** - Neutral LEDs
- b** - Troll button
- c** - Transfer button
- d** - Dock button
- e** - Throttle only
- f** - 1 lever button
- g** - Sync button

- Control handle tension adjustment screw - This screw can be adjusted to increase or decrease the tension on the control handle (cover must be removed). This will help prevent unwanted motion of the handle in rough water. Turn the screw clockwise to increase tension and counterclockwise to decrease tension. Adjust to tension desired.

FEATURES AND CONTROLS

10. Detent tension adjustment screw - This screw can be adjusted to increase or decrease the effort to move control handle out of detent positions (cover must be removed). Turning the screw clockwise will increase tension. Adjust to tension desired.

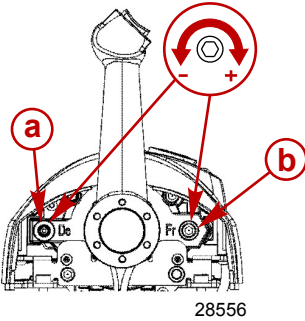

a - Detent tension adjustment screw

b - Control handle tension adjustment screw

28556

SYNCHRONIZING ENGINES

The auto synchronizing feature, when engaged, will automatically adjust all engine speeds to match the speed of the starboard engine.

Press the "SYNC" button on the CAN trackpad to turn auto synchronization on or off. When the sync LED is yellow, the "SYNC" button has been pressed, but the conditions are not right for auto synchronization to engage. When the sync LED turns red, engine synchronization has been engaged. The engines will remain synchronized as long as engine speed is over 900 RPM for two seconds, remote control handles are positioned within 10% of each other, and the engines are below 95% throttle opening.

To disengage the auto synchronization feature, press the "SYNC" button.

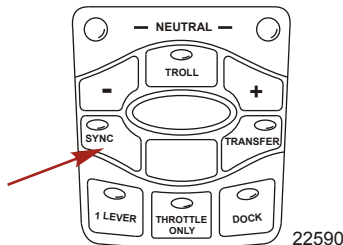

22590

FEATURES AND CONTROLS

HELM TRANSFER

WARNING

Avoid serious injury or death from loss of boat control. The boat operator should never leave the active station while engine is in gear. Helm transfer should only be attempted while both stations are manned. One-person helm transfer should only be performed while engine is in neutral.

NOTE: *Neutral position is preferred when doing a station transfer. If conditions do not allow the remote control to be placed in the neutral position, a helm transfer can be done while in gear.*

The helm transfer function allows the boat operator to select which helm is in control of engine operation. Pressing the "TRANSFER" button two times allows engine control to be transferred to a new helm. When a helm transfer is initiated, the control will automatically start adjusting engine RPM and gear position to match the control handle setting at the new helm. Adjust the control handles to the desired throttle and gear position.

Once the "TRANSFER" button is pressed, the transfer LED will light up and one beep will sound. Press the "TRANSFER" button again to complete the helm transformation. When helm transformation is complete, another beep will sound and the transfer LED will turn off.

NOTE: *There is a 10 second time frame to complete a helm transfer. If the helm transfer is not completed, the action will be cancelled and a double beep will sound. Pressing the "TRANSFER" button again will reinitiate a helm transfer.*

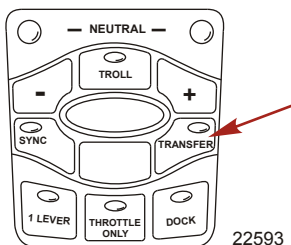

FEATURES AND CONTROLS

Synchronizing Helms Prior to Transfer

Pressing the "TRANSFER" button allows the boat operator 10 seconds to match up the control handle settings at the new helm with the handle settings that are at the old (to be inactive) helm. If the handles are not matched, the neutral lights will flash. The light blinks faster as the handles are nearing match position. Once the light stays on continuously, the handles are matched and the button can be pressed again to complete the transfer. This completes the transfer process, and gives control to the new station. If the helm transfer is not completed within 10 seconds, the action will be cancelled.

Warning System

WARNING HORN SIGNALS

When the key switch is turned to the "ON" position, the horn (located on the command module harness) will turn on for a moment as a test to indicate the horn is working.

There are two types of warning horns to alert the operator of an active problem within the engine's operating system.

1. **Continuous six second beep:** Indicates a critical engine condition. Depending on the condition, the Engine Guardian System may engage and protect the engine by limiting it's power. You should return to port immediately and contact your servicing dealer.
2. **Intermittent short beeps for six seconds:** Indicates a noncritical engine condition. This condition does not require immediate attention. You may continue using your boat, however, depending on the nature of the problem, the engine's power may be limited by the Engine Guardian System (see Engine Guardian System following) to protect the engine. You should contact your servicing dealer at your earliest convenience.

FEATURES AND CONTROLS

It is important to note that in either of the above scenarios, the horn will only sound one time. If you key the engine off and restart it, the horn will sound again, one time, if the fault is still present. For visual display of the specific engine functions and additional engine data, refer to SmartCraft Product information, following.

A few of the noncritical conditions indicated by the intermittent short beeps for six seconds can be corrected by the operator. These operator correctable conditions are as follows:

- Water in the engine mounted fuel filter. Refer to **Maintenance – Water Separating Fuel Filter**.
- Cooling system (water pressure or engine temperature) problem. Stop the engine and check the water intake holes in the lower unit for obstruction.
- Low engine oil level. Refer to **Fuel and Oil – Checking and Adding Engine Oil**.

ENGINE GUARDIAN SYSTEM

The Engine Guardian System monitors the critical sensors on the engine for any early indications of problems. Engine Guardian is functional whenever your engine is operating, so you never have to be concerned about whether or not you are protected. The system will respond to a problem by sounding the warning horn for six seconds and/or reducing engine power in order to provide engine protection.

If the Guardian System has been activated, reduce throttle speed. The problem will need to be identified and corrected, if possible. The system must be reset before the engine will operate at higher speeds. Moving the throttle lever back to the idle position will reset the system.

SMARTCRAFT PRODUCT

A Mercury SmartCraft System instrument package can be purchased for this outboard. A few of the functions the instrument package will display are engine RPM, coolant temperature, oil pressure, water pressure, battery voltage, fuel consumption, and engine operating hours.

FEATURES AND CONTROLS

The SmartCraft Instrument package will also aid in Engine Guardian diagnostics. The SmartCraft Instrument package will display critical engine alarm data and potential problems.

Power Trim and Tilt

The outboard has a trim/tilt control called power trim. This enables the operator to easily adjust the position of the outboard by pressing the trim switch. Moving the outboard in closer to the boat transom is called trimming in or trimming down. Moving the outboard further away from the boat transom is called trimming out or trimming up. The term trim generally refers to the adjustment of the outboard within the first 20° range of travel. This is the range used while operating the boat on plane. The term tilt is generally used when referring to adjusting the outboard further up out of the water. With the engine not running and the key switch in the "ON" position, the outboard can be tilted out of the water. At low idle speed (2000 RPM and below), the outboard can also be tilted up past the trim range to permit shallow water operation.

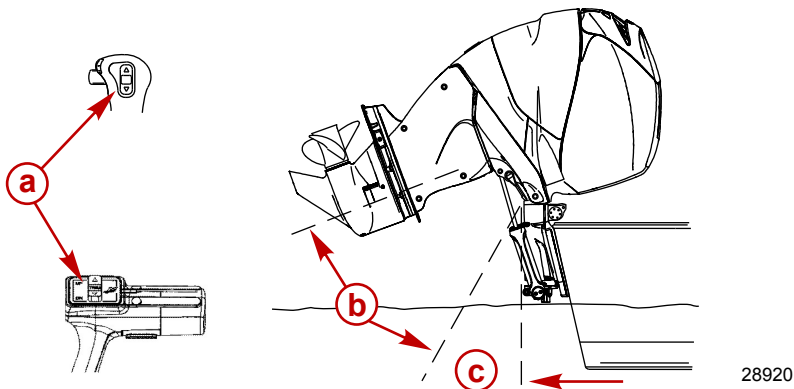

- a** - Trim switch
- b** - Tilt range of travel
- c** - Trim range of travel

28920

FEATURES AND CONTROLS

POWER TRIM OPERATION

With most boats, operating around the middle of the trim range will give satisfactory results. However, to take full advantage of the trimming capability there may be times when you choose to trim the outboard all the way in or out. Along with an improvement in some performance aspects comes a greater responsibility for the operator, this being an awareness of some potential control hazards.

Consider the following lists carefully:

1. Trimming in or down can:

- Lower the bow.
- Result in quicker planing off, especially with a heavy load or a stern heavy boat.
- Generally improve the ride in choppy water.
- In excess, can lower the bow of some boats to a point where they begin to plow with their bow in the water while on plane. This can result in an unexpected turn in either direction (called bow steering or oversteering) if any turn is attempted, or if a significant wave is encountered.

WARNING

Operating the boat at high speeds with the outboard trimmed too far under can create excessive bow steer, resulting in the operator losing control of the boat. Install the trim limit pin in a position that prevents excessive trim under and operate the boat in a safe manner.

2. Trimming out or up can:

- Lift the bow higher out of the water.
- Generally increase top speed.
- Increase clearance over submerged objects or a shallow bottom.
- In excess, can cause boat porpoising (bouncing) or propeller ventilation.
- Cause engine overheating if any cooling water intake holes are above the waterline.

FEATURES AND CONTROLS

TILTING TO FULL UP POSITION

Tilt at Helm

NOTE: The trim/tilt switch will remain active for 15 minutes after the ignition key switch has been turned off.

1. If the ignition key switch has been turned off for over 15 minutes, turn it to the "ON" position.
2. Press the trim/tilt switch to the up position. The outboard will tilt up until the switch is released or it reaches its maximum tilt position.

Tilt at Engine

The cowl mounted auxiliary tilt switch can be used to tilt the outboard with the key switch in the "OFF" position.

Tilt Support Lever

1. Rotate the tilt support lever down.
2. Lower outboard until tilt support bracket rests on the pedestal.
3. Disengage the tilt support bracket, by raising the outboard up and rotating the tilt support lever up. Lower the outboard.

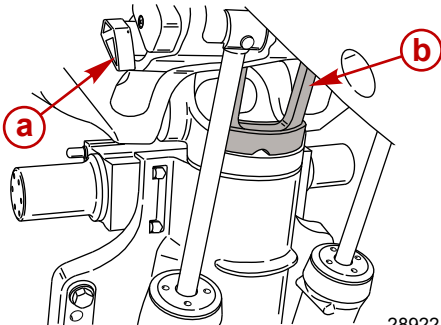

- a** - Tilt support lever
b - Tilt support bracket

FEATURES AND CONTROLS

MANUAL TILTING

If the outboard cannot be tilted using the power trim/tilt switch, the outboard can be manually tilted.

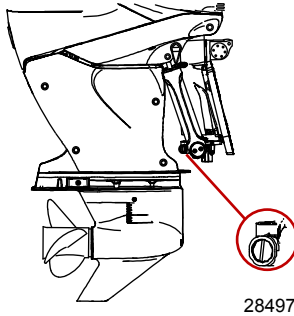

NOTE: The manual tilt release valve must be tightened before operating the outboard to prevent the outboard from tilting up during reverse operation.

Turn out the manual tilt release valve three turns counterclockwise. This allows manual tilting of the outboard. Tilt the outboard to the desired position and tighten the manual tilt release valve.

AUXILIARY TILT SWITCH

The auxiliary tilt switch can be used to tilt the outboard up or down using the power trim system.

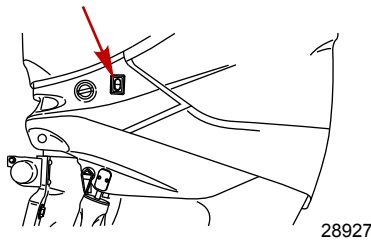

SHALLOW WATER OPERATION

When operating your boat in shallow water, you can tilt the outboard beyond the maximum trim range to prevent hitting bottom.

1. Reduce engine speed below 2000 RPM.

FEATURES AND CONTROLS

2. Tilt outboard up. Make sure all the water intake holes stay submerged at all times.
3. Operate the engine at slow speed only. With the outboard tilted past 20° trim limit, the warning horn will sound and engine speed will be automatically limited to approximately 2000 RPM. The outboard must be tilted (trimmed) down below the maximum trim range to allow operation above 2000 RPM.

OPERATION

Prestarting Check List

- Operator knows safe navigation, boating, and operating procedures.
- An approved personal flotation device of suitable size for each person aboard and readily accessible (it is the law).
- A ring type life buoy or buoyant cushion designed to be thrown to a person in the water.
- Know your boats' maximum load capacity. Look at the boat capacity plate.
- Fuel supply OK.
- Arrange passengers and load in the boat so the weight is distributed evenly and everyone is seated in a proper seat.
- Tell someone where you are going and when you expect to return.
- It is illegal to operate a boat while under the influence of alcohol or drugs.
- Know the waters and area you will be boating; tides, currents, sand bars, rocks, and other hazards.
- Make inspection checks listed in **Maintenance - Inspection and Maintenance Schedule**.

Operating in Freezing Temperatures

When using your outboard or having your outboard moored in freezing or near freezing temperatures, keep the outboard tilted down at all times so the gearcase is submerged. This prevents the trapped water in the gearcase from freezing and causing possible damage to the water pump and other components.

If there is a chance of ice forming on the water, the outboard should be removed and drained completely of water. If ice should form at the water level inside the outboard driveshaft housing, it will block water flow to the engine causing possible damage.

OPERATION

Operating in Saltwater or Polluted Water

We recommend that you flush the internal water passages of your outboard with fresh water after each use in salt or polluted water. This will prevent a buildup of deposits from clogging the water passages. Refer to **Maintenance - Flushing the Cooling System**.

If you keep your boat moored in the water, always tilt the outboard so the gearcase is completely out of water (except in freezing temperatures) when not in use.

Wash the outboard exterior and flush out the exhaust outlet of the propeller and gearcase with fresh water after each use. Each month, spray Mercury Precision or Quicksilver Corrosion Guard on external metal surfaces. Do not spray on corrosion control anodes as this will reduce the effectiveness of the anodes.

Engine Break-in Procedure

IMPORTANT: Failure to follow the engine break-in procedures can result in poor performance throughout the life of the engine and can cause engine damage. Always follow break-in procedures.

1. For the first two hours of operation, run the engine at varied throttle settings up to 4500 RPM or at three-quarter throttle, and at full throttle for approximately one minute every ten minutes.
2. For the next eight hours of operation, avoid continuous operation at full throttle for more than five minutes at a time.

Starting the Engine

Before starting, read the **Pre-Starting Check List**, special operating instructions, **Engine Break-in Procedure**, and **Gear Shifting** in the **Operation** section and the remote control features and operation in the **Features and Controls** section.

OPERATION

NOTICE

Without sufficient cooling water, the engine, the water pump, and other components will overheat and suffer damage. Provide a sufficient supply of water to the water inlets during operation.

1. Make sure the cooling water intake is submerged.

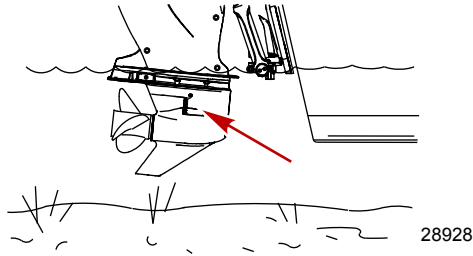

2. Check the engine oil level.

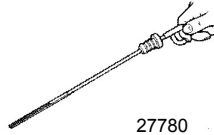

3. Open fuel tank vent on manual venting type tanks.

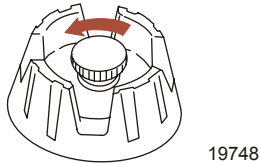

NOTE: The engine will not start unless the lanyard is set to the "RUN" position.

OPERATION

4. Set the lanyard stop switch to the "RUN" position. Refer to **General Information - Lanyard Stop Switch**.



19791

5. Shift outboard to neutral (N) position.

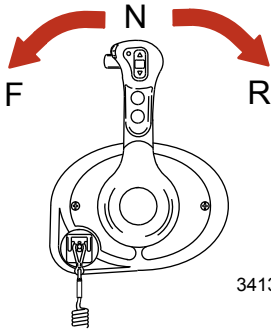

3413

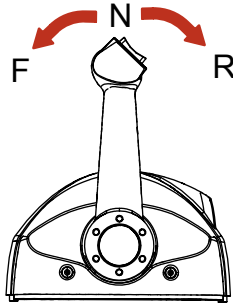

3417

NOTE: For initial start of a new engine or for an engine that ran out of fuel or was drained of fuel, the fuel system should be filled as follows:

Turn the ignition key switch to the "ON" position for approximately one minute. This operates the fuel lift pump. Turn the ignition key switch back to the "OFF" position and then return the ignition key switch to the "ON" position again for an additional minute. Turn the ignition key switch back to the "OFF" position. The filling of the fuel system is complete.

OPERATION

6. Ignition key starting - Turn the ignition key to "START" position and release the key. The electronic starting system will automatically crank the engine for starting. If the engine fails to start, the engine will stop cranking. Turn the key to "START" position again until engine starts.

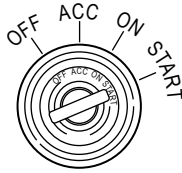

3485

7. After engine starts, check for a steady stream of water flowing out of the water pump indicator hole.

IMPORTANT: If no water is coming out of the water pump indicator hole, stop engine and check the cooling water intake for obstruction. No obstruction may indicate a water pump failure or blockage in the cooling system. These conditions will cause the engine to overheat. Have the outboard checked by your dealer. Operating the engine while overheated will cause engine damage.

Gear Shifting

DTS PANEL MOUNT REMOTE CONTROL

IMPORTANT: Never shift outboard into gear unless engine speed is at idle. Do not shift outboard into forward or reverse when the engine is not running.

OPERATION

- The outboard has three gear shift positions to provide operation: Forward (F), Neutral (N), and Reverse (R).

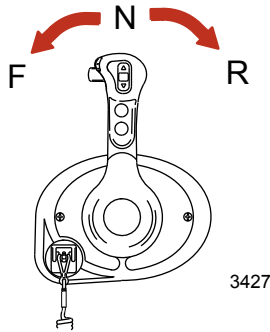

- When shifting, always stop at neutral position and allow the engine speed to return to idle.
- Panel mount remote control requires the operator to always press shift lock while moving the control handle out of the neutral position.

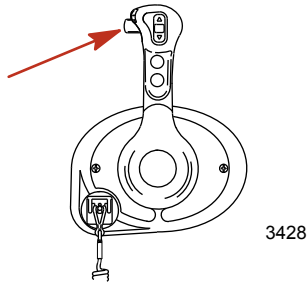

- Advance the control lever to further increase speed.

DTS CONSOLE MOUNT REMOTE CONTROL

IMPORTANT: Never shift outboard into gear unless engine speed is at idle. Do not shift outboard into forward or reverse when the engine is not running.

OPERATION

- The outboard has three gear shift positions to provide operation: Forward (F), Neutral (N), and Reverse (R).

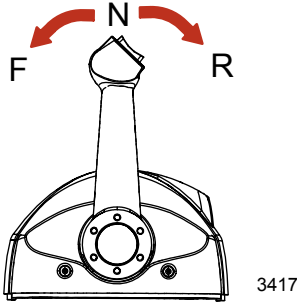

- When shifting, always stop at neutral position and allow the engine speed to return to idle.
- Advance the control lever to further increase speed.

Stopping the Engine

IMPORTANT: Turning key to the "START" position while the engine is running will result in engine shut down, while leaving the DTS system active. This will allow the use of the power trim/tilt from the remote control handle.

Reduce engine speed and shift outboard to neutral position. Turn ignition key to "OFF" position.

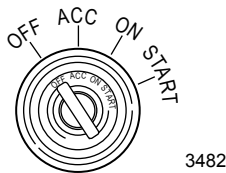

MAINTENANCE

Outboard Care

To keep your outboard in the best operating condition, it is important that your outboard receive the periodic inspections and maintenance listed in the **Inspection and Maintenance Schedule**. We urge you to keep it maintained properly to ensure the safety of you and your passengers, and retain its dependability.

Record maintenance performed in the **Maintenance Log** at the back of this book. Save all maintenance work orders and receipts.

SELECTING REPLACEMENT PARTS FOR YOUR OUTBOARD

We recommend using original Mercury Precision or Quicksilver replacement parts and Genuine Lubricants.

EPA Emissions Regulations

All new outboards manufactured by Mercury Marine are certified to the United States Environmental Protection Agency, as conforming to the requirements of the regulations for the control of air pollution from new outboard motors. This certification is contingent on certain adjustments set to factory standards. For this reason, the factory procedure for servicing the product must be strictly followed and, wherever practicable, returned to the original intent of the design. **Maintenance, replacement, or repair of the emission control devices and systems may be performed by any marine spark ignition (SI) engine repair establishment or individual.**

MAINTENANCE

EMISSION CERTIFICATION LABEL

An emission certification label, showing emission levels and engine specifications directly related to emissions, is placed on the engine at the time of manufacture.

The diagram shows a rectangular label with the Mercury logo on the left and the title "EMISSION CONTROL INFORMATION" on the right. The label contains several lines of text and input fields. Red circles with letters a through j are placed around the label, with arrows pointing to specific fields: a points to "IDLE SPEED (in gear)", b to "hp", c to "L", d to "kw", e to a date field, f to "FAMILY:", g to "HC+NOx:FEL:", h to "CO FEL:", i to "SPARK PLUG:" and "GAP:", and j to "LOW PERM/HIGH PERM:". The text on the label includes: "THIS ENGINE CONFORMS TO [] CALIFORNIA AND U.S. EPA EMISSION REGULATIONS FOR SPARK IGNITION MARINE ENGINES", "REFER TO OWNERS MANUAL FOR REQUIRED MAINTENANCE, SPECIFICATIONS, AND ADJUSTMENTS", "IDLE SPEED (in gear): []", "FAMILY: []", "[] hp", "[] L", "HC+NOx:FEL: [] g/kWh", "[] kw", "CO FEL: [] g/kWh", "SPARK PLUG: []", "GAP: []", and "LOW PERM/HIGH PERM: []".

43210

- a** - Idle speed
- b** - Engine horsepower
- c** - Piston displacement
- d** - Engine power - kilowatts
- e** - Date of manufacture
- f** - Family number
- g** - Regulated emission limit for the engine family
- h** - Regulated emission limit for the engine family
- i** - Recommended spark plug and gap
- j** - Percent of fuel line permeation

OWNER RESPONSIBILITY

The owner/operator is required to have routine engine maintenance performed to maintain emission levels within prescribed certification standards.

The owner/operator is not to modify the engine in any manner that would alter the horsepower or allow emission levels to exceed their predetermined factory specifications.

Inspection and Maintenance Schedule

BEFORE EACH USE

- Check engine oil level. See **Fuel and Oil - Checking and Adding Engine Oil**.

MAINTENANCE

- Check that lanyard stop switch stops the engine.
- Inspect the outboard for tightness to the boat transom. If any looseness of the outboard or mounting fasteners exist, retorque the outboard mounting fasteners to 75 Nm (55 lb-ft).
- Visually inspect the fuel system for deterioration or leaks.
- Check steering system for binding or loose components.
- Visually check power steering fittings and hoses for leaks or signs of damage. Check tie bar fasteners (multiple outboard rigs) for proper tightness.
- Check propeller blades for damage.

AFTER EACH USE

- Flush out the outboard cooling system if operating in salt or polluted water. See **Flushing the Cooling System**.
- Wash off all salt deposits and flush out the exhaust outlet of the propeller and gearcase with fresh water if operating in saltwater.

EVERY 100 HOURS OF USE OR ONCE YEARLY, WHICHEVER OCCURS FIRST

- Change engine oil and replace the oil filter. The oil should be changed more often when the engine is operated under adverse conditions such as extended trolling. See **Changing Engine Oil**.
- Retorque the outboard mounting fasteners that fasten the outboard to the boat transom. Torque to 75 Nm (55 lb-ft).¹
- Inspect thermostat visually for corrosion and/or for a broken spring. Make sure thermostat closes completely at room temperature.¹
- Check engine water separating fuel filter for contaminants. Clean and/or replace filter. See **Fuel System**.
- Check corrosion control anodes. Check more frequently when used in saltwater. See **Corrosion Control Anode**.
- Drain and replace gearcase lubricant. See **Gearcase Lubrication**.

1. These items should be serviced by an authorized dealer.

MAINTENANCE

- Check power steering fluid. See **Checking Power Steering Fluid**.
- Inspect battery. See **Battery Inspection**.
- Saltwater usage: Remove and inspect spark plugs for corrosion and replace spark plugs as necessary. Apply a thin coating of Anti-Seize Compound only on threads of spark plug prior to installation. See **Spark Plug Inspection and Replacement**.

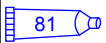
Tube Ref No.	Description	Where Used	Part No.
 81	Anti-Seize Compound	Spark plug threads	92-898101385

- Check wiring and connectors.
- Check tightness of bolts, nuts, and other fasteners.
- Check cowl seals to make sure seals are intact and not damaged.
- Check internal cowl sound reduction foam (if equipped) to make sure foam is intact and not damaged.
- Check that the intake silencer (if equipped) is in place.
- Check that the idle relief muffler (if equipped) is in place.
- Check for loose hose clamps and rubber boots (if equipped) on the air intake assembly.

EVERY 300 HOURS OF USE OR THREE YEARS

IMPORTANT: Engine oil must be drained before removing gearcase to avoid oil spillage. Perform scheduled water pump replacement in combination with an engine oil change.

- Replace water pump impeller (more often if overheating occurs or reduced water pressure is noted).¹
- Check power trim fluid. See **Checking Power Trim Fluid**.
- Replace high-pressure in-line fuel filter.¹
- Replace spark plugs at first 300 hours or three years. After that, inspect spark plugs every 300 hours or three years. Replace spark plugs as needed. See **Spark Plug Inspection and Replacement**.

MAINTENANCE

- Replace accessory drive belt. See **Accessory Drive Belt Inspection**.¹

BEFORE PERIODS OF STORAGE

- Refer to storage procedure. See **Storage** section.

Flushing the Cooling System

Flush the internal water passages of the outboard with fresh water after each use in salt, polluted, or muddy water. This will help prevent a buildup of deposits from clogging the internal water passages.

NOTE: *The outboard can be tilted or in the vertical operating position during flushing.*

1. With the engine turned off, place the outboard in either the operating position (vertical) or in a tilted position.
2. Disconnect the flush connector from the fitting on the bottom cowl.

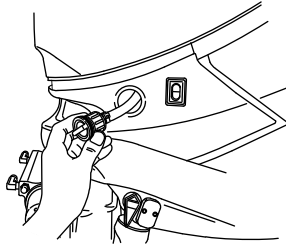

28726

3. Thread a water hose into the flush fitting.

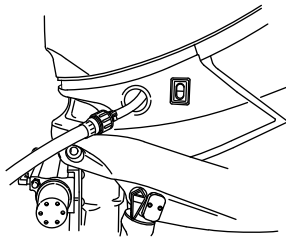

28727

4. Turn on the water tap (1/2 maximum) and let the water flush through the cooling system for about 15 minutes.

MAINTENANCE

5. When flushing is complete, turn off water and disconnect the water hose.
6. Install the flushing connector to the fitting on the bottom cowl. Tighten the connector securely.

Cowl Removal and Installation

COWL REMOVAL

IMPORTANT: Most maintenance points are accessible by removing the top cowl only.

1. Pull up on the top cowl lock latch.

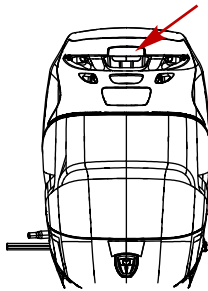

28946

2. Pull top cowl forward and lift off.
3. Pull lower cowl release latch up.
4. Remove rear cowl towards aft of outboard.

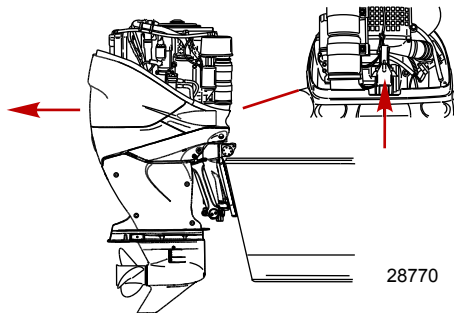

28770

COWL INSTALLATION

1. Position lower cowl from aft side of outboard. Make sure it fits properly in the rubber seal.

MAINTENANCE

2. Lock cowl in place by pulling lower cowl latch down.

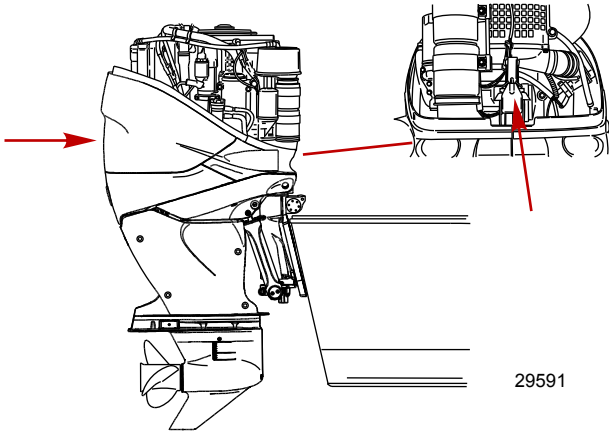

3. Place top cowl into position over engine, front first. Ensure cowl fits properly into the rubber seal.
4. The top cowl will lock into place when downward pressure is applied to the back side of cowl. Ensure cowl is securely fastened by pulling up on back of cowl.

Cleaning Care for Top and Bottom Cowls

IMPORTANT: Dry wiping (wiping the plastic surface when it is dry) will result in minor surface scratches. Always wet the surface before cleaning. Do not use detergents containing hydrochloric acid. Follow the cleaning and waxing procedure.

CLEANING AND WAXING PROCEDURE

1. Before washing, rinse the cowls with clean water to remove dirt and dust that may scratch the surface.
2. Wash the cowls with clean water and a mild nonabrasive soap. Use a soft clean cloth when washing.
3. Dry thoroughly with a soft clean cloth.
4. Wax the surface using a nonabrasive automotive polish (polish designed for clear coat finishes). Remove the applied wax by hand using a clean soft cloth.
5. To remove minor scratches, use Mercury Marine Cowl Finishing Compound (92-859026K 1).

MAINTENANCE

Cleaning Care for the Powerhead (Saltwater Use)

If the outboard is operated in saltwater, remove the top cowl and flywheel cover. Inspect the powerhead and powerhead components for salt build-up. Wash off any salt build-up from the powerhead and powerhead components with fresh water. Keep water spray out of the air filter/intake and alternator. After washing, allow the powerhead and components to dry. Apply Quicksilver or Mercury Precision Lubricants Corrosion Guard spray on the external metal surfaces of the powerhead and powerhead components. Do not allow the Corrosion Guard spray to come in contact with the alternator drive belt, belt pulleys or the outboard motor mounts.

IMPORTANT: Do not allow lubricant or Corrosion Guard spray to come in contact with the alternator drive belt or the belt pulleys. The alternator drive belt could slip and be damaged if it becomes coated with any lubricant or Corrosion Guard spray.

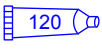
Tube Ref No.	Description	Where Used	Part No.
 120	Corrosion Guard	External metal surfaces of the powerhead and powerhead components.	92-802878 55

Battery Inspection

The battery should be inspected at periodic intervals to ensure proper engine starting capability.

IMPORTANT: Read the safety and maintenance instructions which accompany your battery.

1. Turn off the engine before servicing the battery.
2. Ensure the battery is secure against movement.
3. Battery cable terminals should be clean, tight, and correctly installed. Positive to positive and negative to negative.
4. Ensure the battery is equipped with a nonconductive shield to prevent accidental shorting of battery terminals.

MAINTENANCE

Verado Engine Battery Specifications

IMPORTANT: Verado engines require a 12 volt AGM (absorbed glass mat) marine starting battery that meets the minimum ratings.

For best performance, Mercury Marine does not recommend using the more common flooded (wet cell) or gel cell type lead acid batteries for starting Verado engines.

Each Verado engine must be equipped with its own starting battery.

If the boat application requires additional battery loads for boat accessories or marine electronics, it is recommended that an auxiliary battery, or batteries, be installed.

Choose a 12 volt AGM (absorbed glass mat) battery which meets the following ratings.

USA (SAE) Verado Starting Battery Rating	
Required Verado starting battery	12 volt AGM (absorbed glass mat) battery
Required MCA (marine cranking amps) and reserve capacity	800 minimum marine cranking amps with a minimum reserve capacity of 135 minutes RC25 rating

International (EN) Verado Starting Battery Rating	
Required Verado starting battery	12 volt AGM (absorbed glass mat) battery
Required CCA (cold cranking amps) and Ah (amp hour)	1000 minimum cold cranking amps with a minimum of 180 amp hours

NOTE: Do not use an engine starting battery that does not meet the specified ratings. If a battery that does not meet the ratings is used, the electrical system may perform poorly.

IMPORTANT: Boating industry standards (BIA, ABYC, etc.), federal standards, and Coast Guard regulations must be adhered to when installing the battery. Ensure that battery cable installation meets the pull test requirements and that the positive battery terminal is properly insulated in accordance with regulations.

It is recommended (required in some states) that the battery be installed in an enclosed case. Refer to regulations for your area.

MAINTENANCE

When connecting the engine battery, hex nuts must be used to secure the battery leads to the battery posts. Tighten the hex nuts to the specified torque.

⚠ WARNING

Failure to properly secure the battery leads can result in a loss of power to the Digital Throttle and Shift (DTS) system, leading to serious injury or death due to loss of boat control. Secure the battery leads to the battery posts with hex nuts to avoid loose connections.

Description	Nm	lb-in.	lb-ft
Hex nuts	13.5	120	

IMPORTANT: Battery cable size and length is critical. Refer to Battery Cable Size tables or engine installation manual for size requirements.

The decal needs to be placed on or near the battery box for future service reference. One 5/16 in. and one 3/8 in. hex nut is supplied per battery for wing nut replacement. Metric hex nuts are not supplied.

NOTICE - Verado Engines

USE ONLY AGM BATTERIES!
Verado engines must use an AGM marine battery that meets minimum ratings listed below.

USA (SAE)	International (EN)
800 MCA	1000 CCA
135 min RC25	180 Ah

13.5Nm
(120 lbs. in.)

**DO NOT USE
WING NUTS.**

IMPORTANT:
Battery cable size and length is critical. Refer to engine installation manual for size requirements.

Place decal on or near battery box for future service reference. 5/16" and 3/8" hex nuts supplied for wing nut replacement. Metric hex nuts not supplied.

8M0034050

33871

MAINTENANCE

Air Filter

The air filter assembly is a serviceable item and can be cleaned with warm soap water if required.

AIR FILTER REMOVAL AND CLEANING

1. Loosen air filter clamp screw.
2. Remove crankcase ventilation hose.

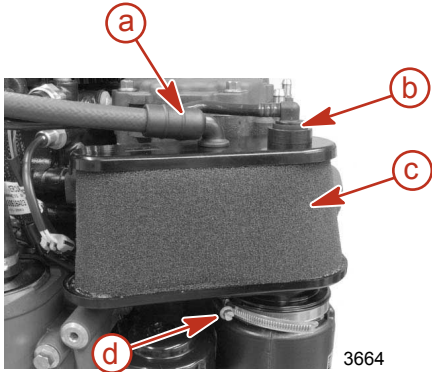

- a** - Crankcase ventilation hose
- b** - Fuel system module (FSM) purge valve hose
- c** - Filter assembly
- d** - Clamp screw

3. Remove air filter assembly and disconnect fuel system module (FSM) purge valve hose by rotating the air filter assembly and pulling on hose.

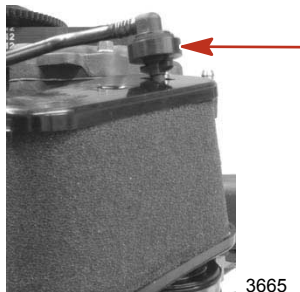

4. Wash air filter assembly in warm soap water.
5. Dry filter assembly with compressed air.
6. Apply 4-Cycle Outboard Oil on rag or towel and lightly pad air filter element. Wipe off excess oil. Air filter element should be moist to the touch.

MAINTENANCE

Tube Ref No.	Description	Where Used	Part No.
	4 Stroke 10W30 Outboard Oil	Air filter element	92-858045K01

AIR FILTER INSTALLATION

1. Install fuel system module (FSM) purge valve hose to air filter assembly.

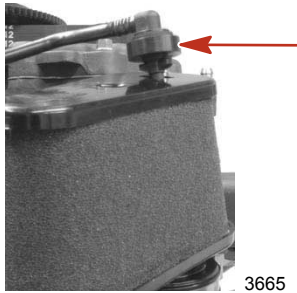

2. Install crankcase ventilation hose.
3. Install air filter assembly and tighten clamp screw securely.

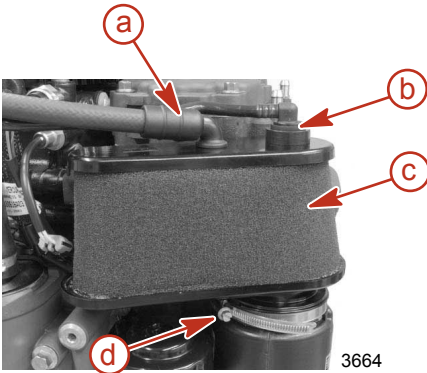

- a** - Crankcase ventilation hose
- b** - Fuel system module (FSM) purge valve hose
- c** - Filter assembly
- d** - Clamp screw

MAINTENANCE

Fuel System

WARNING

Fuel is flammable and explosive. Ensure that the key switch is off and the lanyard is positioned so that the engine cannot start. Do not smoke or allow sources of spark or open flame in the area while servicing. Keep the work area well ventilated and avoid prolonged exposure to vapors. Always check for leaks before attempting to start the engine, and wipe up any spilled fuel immediately.

IMPORTANT: Use an approved container to collect and store fuel. Wipe up spilled fuel immediately. Material used to contain spilled fuel must be disposed of in an approved receptacle.

Before servicing any part of the fuel system:

1. Stop engine and disconnect the battery.
2. Perform fuel system service in a well-ventilated area.
3. Inspect any completed service work for sign of fuel leakage.

FUEL LINE INSPECTION

Visually inspect the fuel line for cracks, swelling, leaks, hardness, or other signs of deterioration or damage. If any of these conditions are found, the fuel line must be replaced.

WATER SEPARATING FUEL FILTER

NOTE: *The warning system will turn on when water in the fuel filter reaches the full level. Refer to **Features and Controls - Warning System**.*

This filter removes moisture and debris from the fuel. If the filter holder becomes filled with water, the water can be removed. If the filter becomes plugged with debris, replace the filter.

Refer to the **Inspection and Maintenance Schedule** for the proper maintenance interval.

Filter Removal

1. Turn the ignition key switch to "OFF" position.
2. Remove the cap from the fuel vapor purge relief valve.

MAINTENANCE

⚠ CAUTION

Failure to release pressure from the fuel system will result in fuel spraying out, which can cause a fire or explosion. Allow the engine to cool completely and release all fuel pressure before servicing any part of the fuel system. Always protect eyes and skin from pressurized fuel and vapors.

3. Place a rag or towel around the valve. Release the fuel pressure by pushing in on the valve stem.

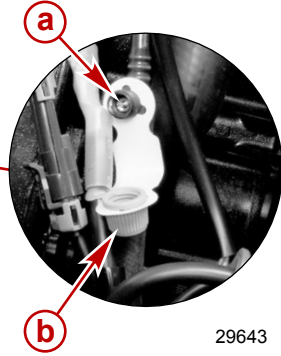
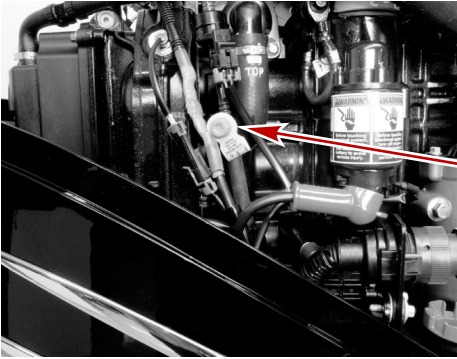

- a** - Fuel vapor purge relief valve
- b** - Cap

MAINTENANCE

- Slide the filter holder up to release it from the bracket.
Hoses and wire harness can remain attached to filter holder.

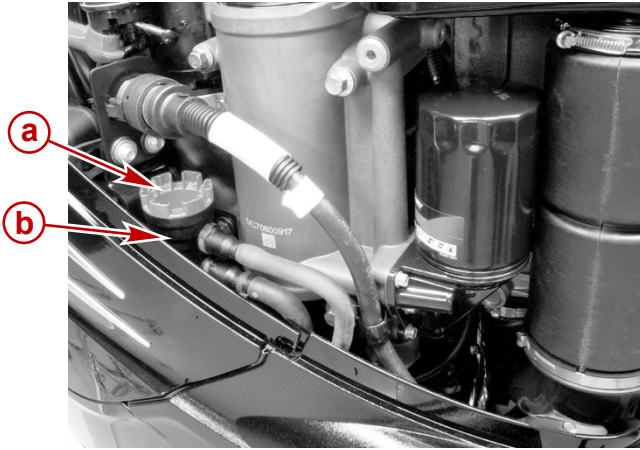

29644

- a** - Fuel filter
- b** - Filter holder

- Use the fuel filter removal/installation tool or the shaft of a screwdriver between the lugs on the filter cap and unscrew the fuel filter.

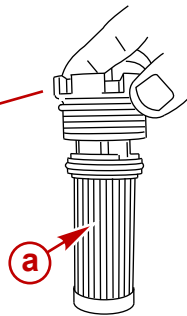
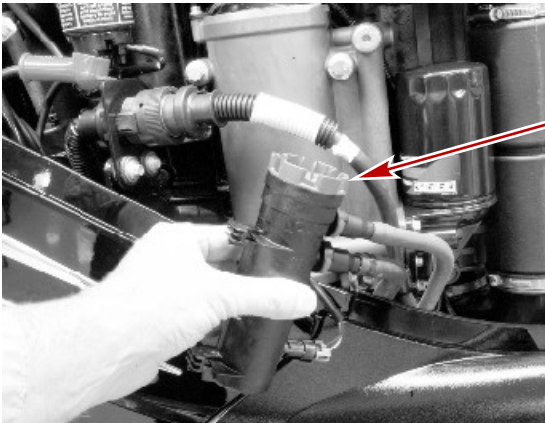

29642

- a** - Fuel filter

MAINTENANCE

Filter Draining

1. Tip the filter holder to drain any fluid into an approved container.

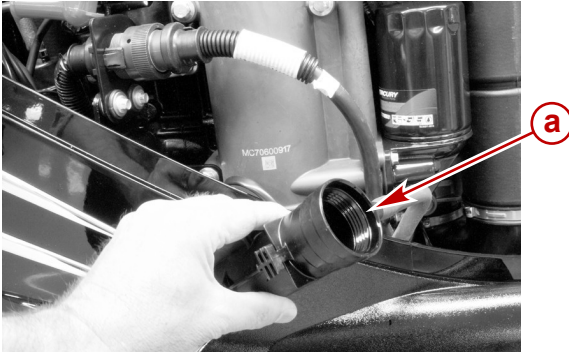

29648

a - Filter holder

Filter Installation

1. Lubricate the O-ring seals with oil.
2. Install the filter and tighten securely.

MAINTENANCE

- Place the filter holder mounting tabs into the slots on the bracket and push down on the filter holder to slide the mounting tabs into the lock position.

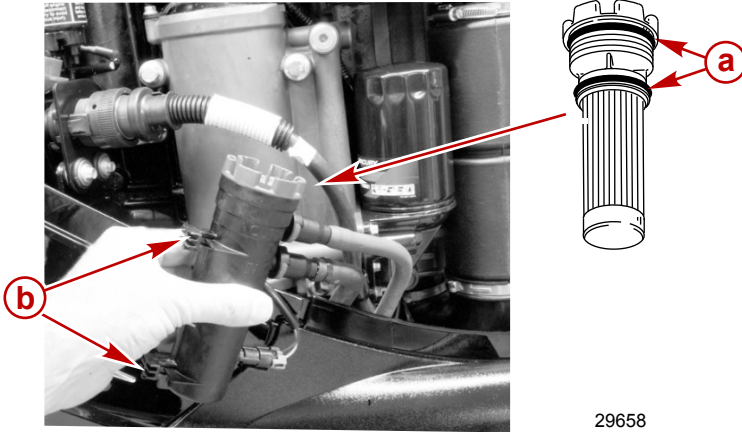

- a** - O-ring seals
- b** - Filter holder mounting tabs

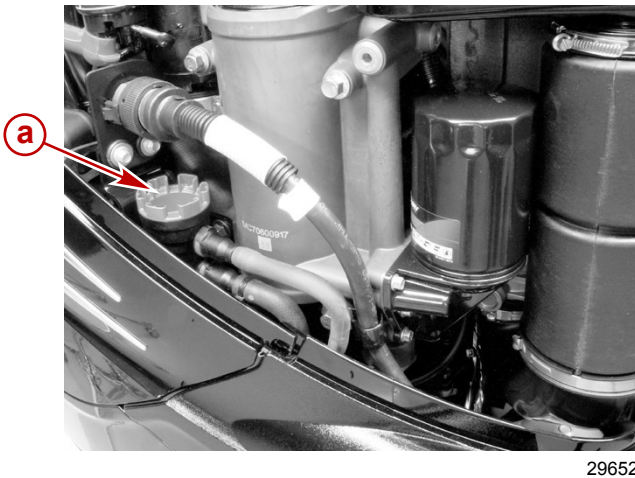

- a** - Fuel filter installed

MAINTENANCE

IMPORTANT: Visually inspect for fuel leakage from the filter while turning the ignition key to the run position, forcing fuel into the filter.

Corrosion Control Anode

The outboard has corrosion control anodes at different locations. An anode helps protect the outboard against galvanic corrosion by sacrificing its metal to be slowly eroded instead of the outboard metals.

Each anode requires periodic inspection, especially in saltwater which will accelerate the erosion. To maintain this corrosion protection, always replace the anode before it is completely eroded. Never paint or apply a protective coating on the anode, as this will reduce effectiveness of the anode.

Two anodes are located on each side of the gearcase. Another anode is installed on the bottom of the pedestal. Two more anodes are located on the bottom of each power trim ram.

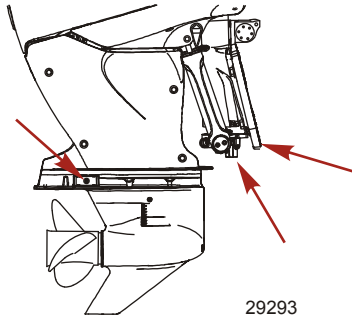

Propeller Replacement

1. Shift outboard to neutral position.

MAINTENANCE

2. Straighten the bent tabs on the propeller nut retainer.

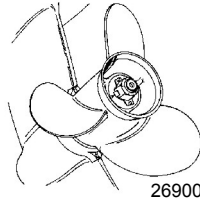

3. Place a block of wood between gearcase and propeller to hold propeller and remove propeller nut.

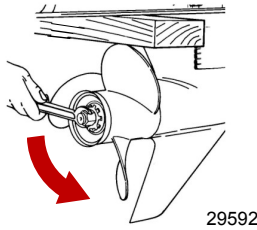

4. Pull propeller straight off shaft. If propeller is seized to the shaft and cannot be removed, have the propeller removed by an authorized dealer.
5. To aid in future removal of the propeller, liberally coat the propeller shaft splines with one of the following Mercury/Quicksilver products:

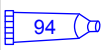
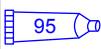
Tube Ref No.	Description	Where Used	Part No.
 94	Anti-Corrosion Grease	Propeller shaft splines	92-802867Q 1
 95	2-4-C with PTFE	Propeller shaft splines	92-802859A 1

MAINTENANCE

6. **Flo-Torq II drive hub propellers** - Install forward thrust hub, replaceable drive sleeve, propeller, thrust hub, propeller nut retainer, and propeller nut onto the shaft.

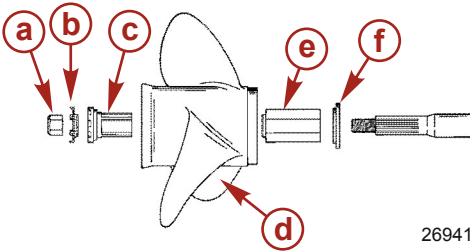

26941

- a** - Propeller nut
- b** - Propeller nut retainer
- c** - Thrust hub
- d** - Propeller
- e** - Replaceable drive sleeve
- f** - Forward thrust hub

7. Place a block of wood between gearcase and propeller and torque to specifications.

Description	Nm	lb-in.	lb-ft
Propeller nut	75		55

8. Secure propeller nut by bending three of the tabs into the thrust hub grooves.

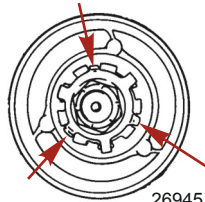

26945

Spark Plug Inspection and Replacement

1. Remove top and rear cowlings. Refer to **Cowl Removal and Installation**.
2. Disconnect the six wiring harness connectors from pencil coil connections.

MAINTENANCE

- Remove mounting bolts, using a twisting motion, and pull pencil coils from spark plugs.

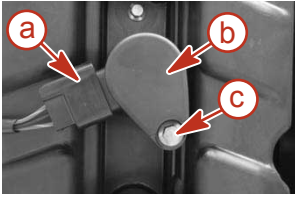

3658

- a** - Wiring harness connector
- b** - Pencil coil
- c** - Bolt

- Remove the spark plugs to inspect. Replace spark plug if electrode is worn, threads of seal area are corroded, or the insulator is rough, cracked, broken, blistered, or fouled.

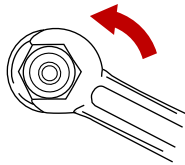

28438

- Set the spark plug gap to specifications.

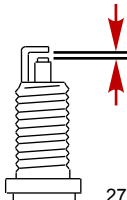

27848

Spark Plug	
Spark plug gap	0.8 mm (0.0315 in.)

- Saltwater use - Apply a thin coating of Anti-Seize Compound only on threads of spark plugs.

Tube Ref No.	Description	Where Used	Part No.
81	Anti-Seize Compound	Spark plug threads	92-898101385

- Clean area of spark plug seat.

MAINTENANCE

8. Before installing spark plugs, clean off any dirt on the spark plug seats. Install plugs finger-tight, and then tighten 1/4 turn or torque to specifications.

Description	Nm	lb. in.	lb. ft.
Spark plug	27		20

9. Push pencil coils into place over the spark plugs using a twisting motion.

10. Secure coils with retained bolts. Torque to specifications.

Description	Nm	lb. in.	lb. ft.
Bolts	8	71	

11. Connect the six wiring harness connectors to pencil coil connections.

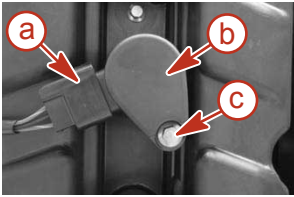

3658

- a** - Wiring harness connector
b - Pencil coil
c - Bolt

12. Reinstall rear and top cowls.

Fuses

The electrical wiring circuits on the outboard are protected from overload by fuses in the wiring. If a fuse is blown, try to locate and correct the cause of the overload. If the cause is not found, the fuse may blow again.

Remove the fuse puller from the holder.

MAINTENANCE

Remove the cover from the fuse holder. Remove the suspected blown fuse and look at the silver band inside the fuse. If band is broken, replace the fuse. Replace the fuse with a new fuse with the same amp rating.

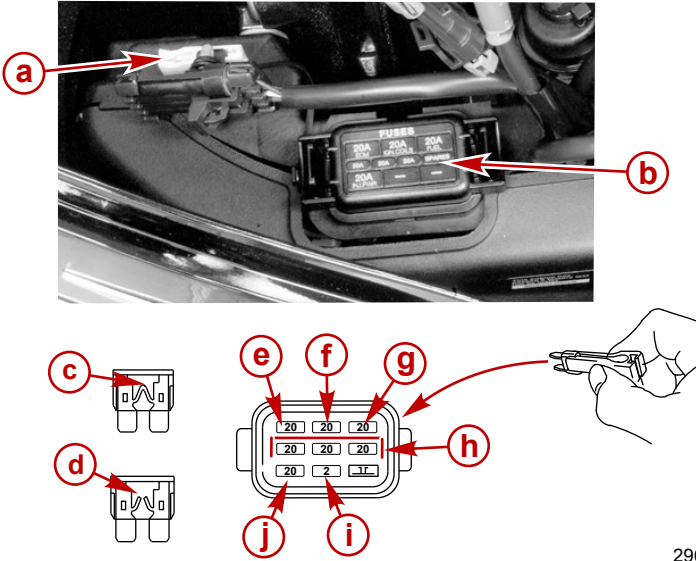

29663

- a** - Fuse puller
- b** - Fuse holder
- c** - Good fuse
- d** - Blown fuse
- e** - Electronic control module and purge valve "ECM" - 20 amp fuse
- f** - Ignition coils "IGN. COILS" - 20 amp fuse
- g** - Fuel delivery "FUEL" - 20 amp fuse
- h** - Spare fuses (3)
- i** - Diagnostics terminal - 2 amp fuse
- j** - Injector power and boost valve "INJ. PWR." - 20 amp fuse

MAINTENANCE

DTS Wiring System

WARNING

Splicing or probing will damage the wire insulation allowing water to enter the wiring. Water intrusion may lead to wiring failure and loss of throttle and shift control. To avoid the possibility of serious injury or death from loss of boat control, do not splice or probe into any wire insulation of the DTS system.

- Verify the harnesses are not routed near sharp edges, hot surfaces, or moving parts.
- Verify all unused connectors and receptacles are covered with a weather cap.
- Verify the harnesses are fastened along the routing path.

Accessory Drive Belt Inspection

Inspect the accessory drive belt and have it replaced by an authorized dealer if any of the following conditions are found.

- Cracks in the back of the belt or in the base of V grooves.
- Excessive wear at the roots of the grooves.
- Rubber portion swollen by oil.
- Belt surfaces roughened.
- Signs of wear on edges or outer surfaces of belt.

Checking Power Trim Fluid

1. Tilt outboard to the full up position.
2. Rotate the tilt support bracket down.
3. Lower outboard until tilt support bracket rests on pedestal.

MAINTENANCE

4. Remove the power trim fill cap. The fill cap only requires 1/4 turn to remove.

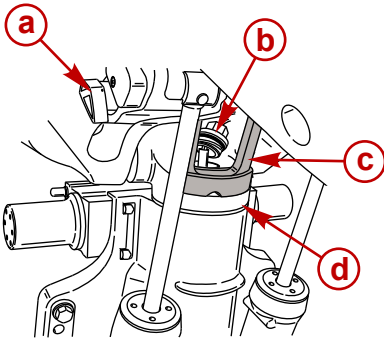

- a** - Tilt support lever
- b** - Power trim fill cap
- c** - Tilt support bracket
- d** - Pedestal

29312

5. The fluid level should be approximately 25 mm (1 in.) from the top of the fill neck. Add Quicksilver or Mercury Precision Lubricants Power Trim and Steering Fluid. If not available, use automotive automatic transmission fluid (ATF).

Tube Ref No.	Description	Where Used	Part No.
 114	Power Trim and Steering Fluid	Power trim system	92-858074K01

6. Reinstall the power trim fill cap. Tighten fill cap 1/4 turn. Cap will snap in place. Do not tighten beyond this point.

MAINTENANCE

Checking Power Steering Fluid

Remove power steering cover and fill cap to check fluid level. The fluid level should be slightly below the bottom of the fill hole. Use SAE 0W-30 synthetic power steering fluid, if needed.

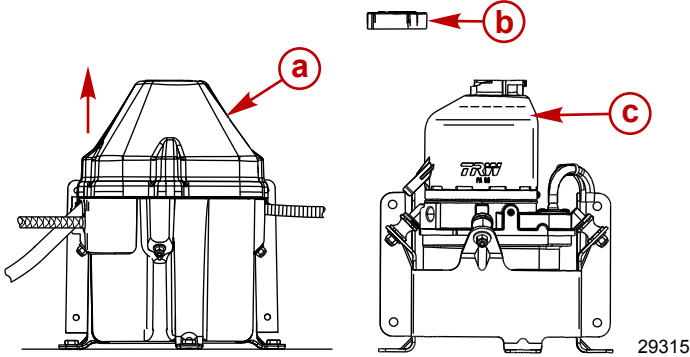

- a** - Power steering cover
- b** - Fill cap
- c** - Fill/full level

Tube Ref No.	Description	Where Used	Part No.
 138	Synthetic Power Steering Fluid SAE 0W-30	Power steering system	92-858076K01

Changing Engine Oil

ENGINE OIL CAPACITY

Engine oil capacity is approximately 7.0 liter (7.4 US qt).

PUMP METHOD

IMPORTANT: Tilt the outboard out/up past vertical for approximately one minute to allow any trapped oil to drain back to the oil sump.

IMPORTANT: To reduce or prevent oil spillage when removing the oil filter, make sure that the outboard is upright (not tilted) and the engine is cold or has not run for at least one hour.

MAINTENANCE

IMPORTANT: The pump method is preferred to remove engine oil from XXL models. If the drain method is used, an oil drain funnel must be used to divert oil from the lower splash plate and into the container.

1. Tilt the outboard out/up past vertical for approximately one minute to allow any trapped oil to drain back to the oil sump.
2. Place the outboard in a vertical position.
3. Remove the dipstick and slide the adapter tube of the crankcase oil pump through the oil dipstick hole, to the bottom of the engine oil sump.
4. Pump out the engine oil into an appropriate container.

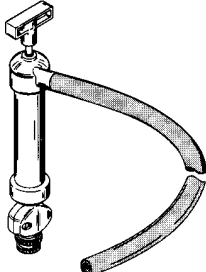
Crankcase Oil Pump	91-90265A 5
 <p>11591</p>	Aids in the removal of engine oil without draining the crankcase.

DRAIN METHOD

1. Tilt the outboard out/up past vertical for approximately one minute to allow any trapped oil to drain back to the oil sump.
2. Place the outboard in a vertical position.
3. Place an appropriate container under the engine oil sump plug. The drain plug/seal washer is located beneath the splash plate on the port side of the outboard.

MAINTENANCE

- Loosen the drain plug/seal washer. Install the oil drain funnel over the drain plug/seal washer.

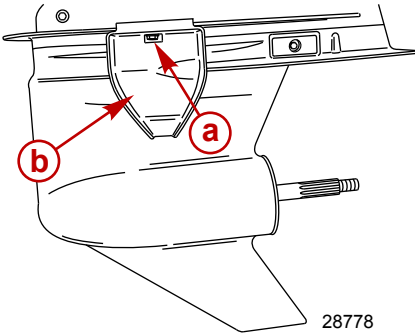

a - Drain plug/seal washer

b - Oil drain funnel

Oil Drain Funnel	91-892866A01
 4993	Diverts draining engine oil from contacting the anti-splash and anti-cavitation plates.

- Remove drain plug/seal washer and drain the engine oil into a container.
- Reinstall the drain plug/seal washer.

CHANGING OIL FILTER

IMPORTANT: To reduce or prevent oil spillage when removing the oil filter, ensure the outboard is upright (not tilted) and the engine is cold or has not run for at least one hour.

- Remove the top cowl.
- Place a rag or towel below the oil filter to absorb any spilled oil.

MAINTENANCE

3. Unscrew the old filter by using an oil filter wrench tool and turning the filter counterclockwise.

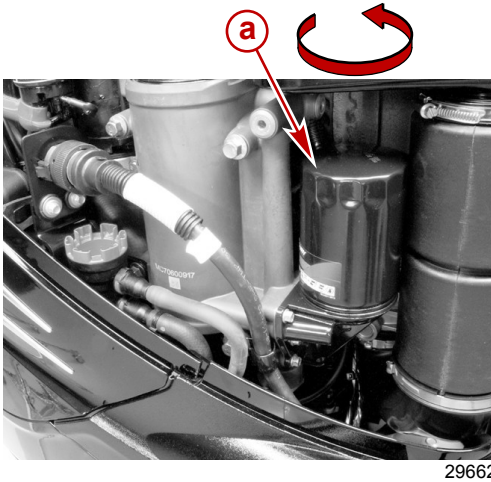

a - Oil filter

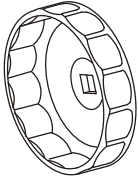
Oil Filter Wrench	91-889277
 5221	Aids in the removal of the oil filter.

4. Clean the oil filter mounting base.
5. Apply a film of clean oil to the filter gasket. Do not use grease.
6. Screw the new filter on until the gasket contacts the base, then tighten the filter another 3/4 to 1 turn.

MAINTENANCE

OIL FILLING

1. Remove the oil fill cap and add the recommended oil to the midpoint of the operating range (midpoint of cross hatched region). Adding approximately 7 liter (7.4 US qt) will bring the oil level to midpoint of the cross hatched region.

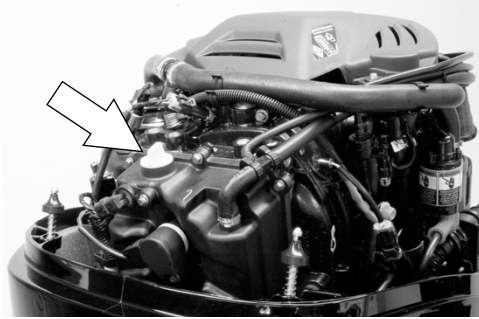

29681

2. Reinstall the oil fill cap.
3. With the outboard in water or a cooling water flush hose connected, idle the engine for five minutes to check for leaks at the oil filter.
4. Stop the engine and check the oil level.

Gearcase Lubrication

When adding or changing gearcase lubricant, visually check for the presence of water in the lubricant. If water is present, it may have settled to the bottom and will drain out prior to the lubricant, or it may be mixed with the lubricant, giving it a milky colored appearance. If water is noticed, have the gearcase checked by your dealer. Water in the lubricant may result in premature bearing failure or, in freezing temperatures, will turn to ice and damage the gearcase.

Examine the drained gearcase lubricant for metal particles. A small amount of metal particles indicates normal gear wear. An excessive amount of metal filings or larger particles (chips) may indicate abnormal gear wear and should be checked by an authorized dealer.

MAINTENANCE

DRAINING GEARCASE

1. Place outboard in a vertical operating position.
2. Remove propeller. Refer to **Propeller Replacement**.
3. Place drain pan below outboard.
4. Remove vent plug and fill/drain plug and drain lubricant.

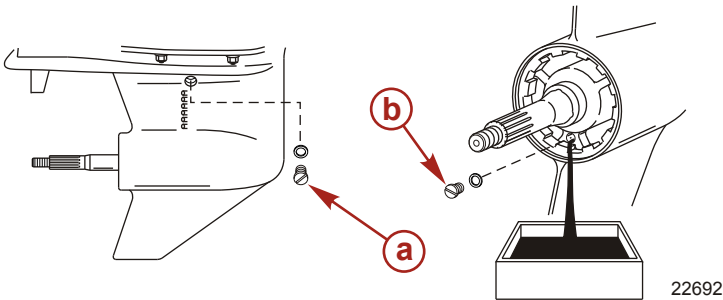

a - Vent plug

b - Fill/drain plug

GEARCASE LUBRICANT CAPACITY

Gearcase lubricant capacity is approximately 970 ml (32.8 fl oz).

GEARCASE LUBRICANT RECOMMENDATION

Mercury or Quicksilver High Performance Gear Lubricant.

CHECKING LUBRICANT LEVEL AND REFILLING GEARCASE

1. Place outboard in a vertical operating position.
2. Remove vent plug/sealing washer.

MAINTENANCE

3. Remove fill/drain plug. Place lubricant tube into the fill hole and add lubricant until it appears at the vent hole.

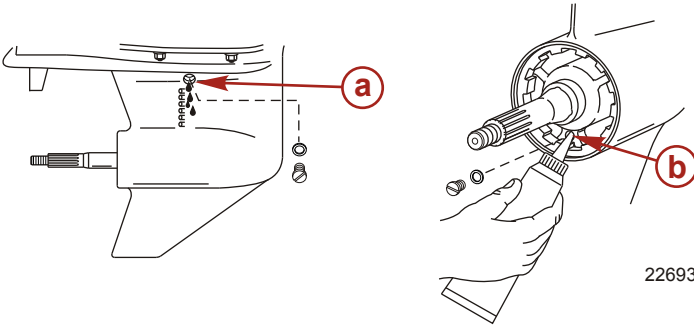

- a** - Vent hole
- b** - Fill hole

IMPORTANT: Replace sealing washers if damaged.

4. Stop adding lubricant. Install the vent plug and sealing washer before removing the lubricant tube.
5. Remove lubricant tube and reinstall cleaned fill/drain plug and sealing washer.

STORAGE

Storage Preparation

The major consideration in preparing your outboard for storage is to protect it from rust, corrosion, and damage caused by freezing of trapped water.

The following storage procedures should be followed to prepare your outboard for out of season storage or prolonged storage (two months or longer).

NOTICE

Without sufficient cooling water, the engine, the water pump, and other components will overheat and suffer damage. Provide a sufficient supply of water to the water inlets during operation.

FUEL SYSTEM

IMPORTANT: Gasoline containing alcohol (ethanol or methanol) can cause a formation of acid during storage and can damage the fuel system. If the gasoline being used contains alcohol, it is advisable to drain as much of the remaining gasoline as possible from the fuel tank, remote fuel line, and engine fuel system.

IMPORTANT: This outboard is equipped with a closed fuel system when the engine is not running. With this closed system, fuel within the engine's fuel system, other than the fuel tank, will remain stable during normal storage periods without the addition of fuel treatment stabilizers.

Fill the fuel tank and engine fuel system with treated (stabilized) fuel to help prevent formation of varnish and gum. Proceed with the following instructions.

- Portable fuel tank - Pour the required amount of Fuel System Treatment and Stabilizer (follow instructions on container) into fuel tank. Tip fuel tank back and forth to mix stabilizer with the fuel.
- Permanently installed fuel tank - Pour the required amount of Fuel System Treatment and Stabilizer (follow instructions on container) into a separate container and mix with approximately one liter (one quart) of gasoline. Pour this mixture into fuel tank.

STORAGE

Tube Ref No.	Description	Where Used	Part No.
 124	Fuel System Treatment and Stabilizer	Fuel tank	92-8M0047932

Protecting External Outboard Components

- Touch up any paint nicks. See your dealer for touch-up paint.
- Spray Quicksilver or Mercury Precision Lubricants Corrosion Guard on external metal surfaces (except corrosion control anodes).

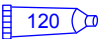
Tube Ref No.	Description	Where Used	Part No.
 120	Corrosion Guard	External metal surfaces	92-802878 55

Protecting Internal Engine Components

IMPORTANT: Refer to Maintenance - Spark Plug Inspection and Replacement for correct procedure for removing spark plugs.

- Remove pencil coils and spark plugs.
- Spray approximately 30 ml (1 fl oz) of Storage Seal Rust Inhibitor into each spark plug hole.

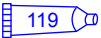
Tube Ref No.	Description	Where Used	Part No.
 119	Storage Seal Rust Inhibitor	Spark plug holes	92-858081K03

- Actuate key/push button start switch to crank the engine through one start cycle, which will distribute the storage seal throughout the cylinders.
- Install spark plugs and pencil coils.

Gearcase

- Drain and refill the gearcase lubricant (refer to **Gearcase Lubrication**).

STORAGE

Positioning Outboard for Storage

Store outboard in an upright (vertical) position to allow water to drain out of the outboard.

NOTICE

Storing the outboard in a tilted position can damage the outboard. Water trapped in the cooling passages or rain water collected in the propeller exhaust outlet in the gearcase can freeze. Store the outboard in the full down position.

Battery Storage

- Follow the battery manufacturer's instructions for storage and recharging.
- Remove the battery from the boat and check water level. Recharge if necessary.
- Store the battery in a cool, dry place.
- Periodically check the water level and recharge the battery during storage.

TROUBLESHOOTING

Starter Motor Will Not Crank the Engine

POSSIBLE CAUSES

- Lanyard stop switch not in "RUN" position.
- Blown 5 amp fuse. Check DTS power harness circuit fuse. Refer to **Maintenance** section.
- Outboard is not shifted to neutral position.
- Shift actuator failure. "Gear Shift Diff" error message shown on System View. Refer to **Maintenance** section.
- Weak battery or battery connections are loose or corroded.
- Ignition key switch failure.
- Wiring or electrical connection faulty.
- Starter motor solenoid or slave solenoid failure.

Engine Will Not Start

POSSIBLE CAUSES

- Incorrect starting procedure. Refer to **Operation** section.
- Old or contaminated gasoline.
- Fuel is not reaching the engine.
 - Fuel tank is empty.
 - Fuel tank vent not open or restricted.
 - Fuel line is disconnected or kinked.
 - Fuel filter is obstructed. Refer to **Maintenance** section.
 - Fuel pump failure.
 - Fuel tank filter obstructed.
- Ignition system component failure.
- Spark plugs fouled or defective. Refer to **Maintenance** section.

Engine Starts But Will Not Shift Into Gear

- Shift actuator failure. "Gear Shift Diff" error message shown on System View. Refer to **Maintenance** section.

TROUBLESHOOTING

Engine Runs Erratically

POSSIBLE CAUSES

- Overheating - Warning horn not working.
- Low oil pressure. Check oil level.
- Spark plugs fouled or defective. Refer to **Maintenance** section.
- Incorrect setup and adjustments.
- Fuel is being restricted to the engine.
 - a. Engine fuel filter is obstructed. Refer to **Maintenance** section.
 - b. Fuel tank filter obstructed.
 - c. Stuck anti-siphon valve located on permanently built-in type fuel tanks.
 - d. Fuel line is kinked or pinched.
- Fuel pump failure.
- Ignition system component failure.

Performance Loss

POSSIBLE CAUSES

- Overheating - Warning horn not working.
- Low oil pressure. Check oil level.
- Throttle not opening fully.
- Damaged propeller or improper propeller size.
- Incorrect engine timing, adjustment, or setup.
- Boat overloaded or load improperly distributed.
- Excessive water in bilge.
- Boat bottom is dirty or damaged.

Battery Will Not Hold Charge

POSSIBLE CAUSES

- Battery connections are loose or corroded.
- Low electrolyte level in battery.
- Worn out or inefficient battery.

TROUBLESHOOTING

- Excessive use of electrical accessories.
- Defective rectifier, alternator, or voltage regulator.
- Open circuit in the alternator output wire (fused link).

OWNER SERVICE ASSISTANCE

Local Repair Service

Always return your outboard to your local authorized dealer should the need for service arise. Only he has the factory trained mechanics, knowledge, special tools, equipment, and genuine parts and accessories to properly service your engine should the need occur. He knows your engine best.

Service Away from Home

If you are away from your local dealer and the need arises for service, contact the nearest authorized dealer. Refer to the Yellow Pages of the telephone directory. If, for any reason, you cannot obtain service, contact the nearest Mercury Marine Service Office.

Parts and Accessories Inquiries

All inquiries concerning genuine replacement parts and accessories should be directed to your local authorized dealer. The dealer has the necessary information to order parts and accessories for you. When inquiring on parts and accessories, the dealer requires the model and serial number to order the correct parts.

Service Assistance

Your satisfaction with your outboard product is very important to your dealer and to us. If you ever have a problem, question or concern about your outboard product, contact your dealer or any authorized Mercury Marine dealership. If additional assistance is required, take these steps.

1. Talk with the dealership's sales manager or service manager. If this has already been done, then contact the owner of the dealership.
2. Should you have a question, concern, or problem that cannot be resolved by your dealership, please contact Mercury Marine Service Office for assistance. Mercury Marine will work with you and your dealership to resolve all problems.

The following information will be needed by the service office:

OWNER SERVICE ASSISTANCE

- Your name and address
- Daytime telephone number
- Model and serial number of your outboard
- The name and address of your dealership
- Nature of problem

Mercury Marine Service Offices

For assistance, call, fax, or write. Please include your daytime telephone number with mail and fax correspondence.

United States, Canada		
Telephone	English - (920) 929-5040 Français - (905) 636-4751	Mercury Marine W6250 W. Pioneer Road P.O. Box 1939 Fond du Lac, WI 54936-1939
Fax	English - (920) 929-5893 Français - (905) 636-1704	
Website	www.mercurymarine.com	

Australia, Pacific		
Telephone	(61) (3) 9791-5822	Brunswick Asia Pacific Group 41-71 Bessemer Drive Dandenong South, Victoria 3175 Australia
Fax	(61) (3) 9706-7228	

Europe, Middle East, Africa		
Telephone	(32) (87) 32 • 32 • 11	Brunswick Marine Europe Parc Industriel de Petit-Rechain B-4800 Verviers, Belgium
Fax	(32) (87) 31 • 19 • 65	

Mexico, Central America, South America, Caribbean		
Telephone	(954) 744-3500	Mercury Marine 11650 Interchange Circle North Miramar, FL 33025 U.S.A.
Fax	(954) 744-3535	

Japan		
Telephone	072-233-8888	Kisaka Co., Ltd. 4-130 Kannabecho Sakai-shi Sakai-ku 5900984 Osaka, Japan
Fax	072-233-8833	

OWNER SERVICE ASSISTANCE

Asia, Singapore		
Telephone	(65) 65466160	Brunswick Asia Pacific Group T/A Mercury Marine Singapore Pte Ltd 29 Loyang Drive Singapore, 508944
Fax	(65) 65467789	