

## Thank You

Thank you for choosing MotorGuide® VariMAX™. With VariMAX, MotorGuide capitalized on many years of experience to provide you with a motor designed to deliver Digital Variable Speed Control and maximum time on the water.

We designed VariMAX with a BluVis™ Function Display to show precise speed setting and battery voltage so you are always in control. The VariMAX Digital Advantage lets you dial in the exact speed for your boat to match the fishing conditions of the day while providing significantly longer run times on your battery charge.

The VariMAX motor and its controls are designed to be very intuitive. You will need to properly install the handle, so please take the time to read this manual. Remember to keep your receipt and immediately register your trolling motor. A warranty card is enclosed or you can complete registration on the internet at [www.motorguide.com](http://www.motorguide.com).

At MotorGuide, we believe there are some things you should Never Stop doing.

**NEVER STOP LEARNING, NEVER STOP IMPROVING,  
AND NEVER, EVER STOP FISHING.**

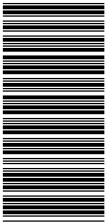

## Warranty Message

The product you purchased comes with a **Limited Warranty** from MotorGuide. The terms of the policy are set forth in the **Warranty Information** section of this manual. The policy statement contains a description of the duration of coverage, **important disclaimers and limitations of damages**, and other related information. Please review this important information.

The description and specifications contained herein were in effect at the time this manual was approved for printing. MotorGuide, whose policy is one of continued improvement, reserves the right to discontinue models at any time, to change specifications, designs, methods, or procedures without notice and without incurring obligation.

MotorGuide, Tulsa, Oklahoma U.S.A.

Litho in U.S.A.

© 2008, Mercury Marine. All Rights Reserved. Reproduction in whole or in part without permission is prohibited.

VariMAX and BluVis are trademarks of Brunswick Corporation.

Mercury, Mercury Marine, MerCruiser, Mercury MerCruiser, Mercury Racing, MotorGuide, Gator, Machete, Mercury Precision Parts, Mercury Propellers, Mariner, Quicksilver, #1 On The Water, Alpha, Bravo, Bravo Two, Pro Max, OptiMax, Sport-Jet, K-Planes, MerCathode, SmartCraft, Total Command, VesselView, Zero Effort, Zeus, M with Waves logo, Mercury with Waves logo, and SmartCraft logo are all registered trademarks of Brunswick Corporation. Mercury Product Protection logo is a registered service mark of Brunswick Corporation.



# TABLE OF CONTENTS

---

## Section 1 - Warranty Information

---

MotorGuide Limited Warranty.....	2
----------------------------------	---

---

## Section 2 - General Information

---

Recording Serial Number.....	6	While You Are Trolling.....	7
Transom Mount.....	6	While the Boat Is Stationary.....	8
Bow Mount.....	7	Passenger Safety Message.....	8
Boater's Responsibilities.....	7	Safe Boating Suggestions.....	8
Protecting People in the Water.....	7		

---

## Section 3 - Product Overview and Assembly

---

Component Identification.....	10	Attaching the Handle.....	12
VariMAX Transom Mount.....	10	Extending and Retracting the Handle.....	13
VariMAX Bow Mount.....	11	Installing the Propeller.....	14

---

## Section 4 - Wiring and Battery Information

---

Battery Precautions.....	18	Battery Connection.....	19
Standard Practices And Procedures.....	18	12-Volt Battery Connection.....	20
Battery Recommendations.....	18	24-Volt Battery Connection.....	21
BluVis Battery Voltage Indicator.....	19		

---

## Section 5 - Mount Installation

---

VariMAX Transom Mount Installation.....	24	Gator 20.8 Breakaway Installation.....	25
Pontoon Mount Installation.....	24	Gator Flex 360.....	26

---

## Section 6 - Operation

---

Installing The Motor Into The Bow Mount.....	30	Adjusting The Steering Tension.....	35
Removing The Motor From The Bow Mount.....	30	Adjusting The Motor Depth.....	35
Stowing The Trolling Motor.....	30	Speed Control.....	36
Transom Mount.....	30	Direction Control.....	36
Bow Mount.....	32	Transom Mount Application.....	37
Deploying The Trolling Motor.....	33	Transom Mount—Backtrolling Application.....	37
Transom Mount.....	33	Bow Mount Application.....	37
Bow Mount.....	34		

---

---

## Section 7 - Maintenance and Storage

---

Trolling Motor Care.....	40	Storage Preparation.....	40
SELECTING REPLACEMENT PARTS.....	40	Battery Inspection.....	41
Inspection And Maintenance Schedule.....	40	Propeller Replacement.....	41
Before Each Use.....	40	Removing The Propeller.....	41
After Each Use.....	40	Installing The Propeller.....	42
Every 100 Hours Of Use Or Annually.....	40		

---

## Section 8 - Custom Applications

---

Repositioning The Top Housing.....	44	Motor Control Wiring.....	46
Setting The Direction Control Switch.....	45		

---

## Section 9 - Owner Service Assistance

---

Troubleshooting.....	50	Mercury Marine Service Offices.....	51
Service Assistance.....	50		

---

## Section 10 - Accessories

---

Trolling Motor Accessories.....	54
---------------------------------	----

---

# Section 1 - Warranty Information

## Table of Contents

---

MotorGuide Limited Warranty.....	2
----------------------------------	---

---

## MotorGuide Limited Warranty

KEEP YOUR ORIGINAL PURCHASE RECEIPT OR BILL OF SALE.

1. For recreational use customers, MotorGuide electric trolling motors are warranted to the original retail purchaser to be free from defects in material or workmanship for the periods listed in the table below:

12 V Trolling Motors — 1 year warranty

24 V Trolling Motors — 2 year warranty

36 V Trolling Motors — 3 year warranty

2. To obtain warranty service, the purchaser should deliver or return the unit (postage prepaid and insured) to any MotorGuide Authorized Service Dealer. **DO NOT RETURN TO PLACE OF PURCHASE** unless they are an authorized service center. Products returned by mail should be carefully packaged and include a note describing the nature of the problem and/or service requested, customer address and phone number. A copy of the receipt, Bill of Sale, registration verification or other proof of purchase is required with the return of the product for warranty consideration. Warranty claims will not be accepted without presentation of purchase receipt for trolling motor, other verification of registration, or Bill of Sale for boat package.
3. MotorGuide, at its discretion, will repair or replace items covered under the terms of this warranty. Neither MotorGuide nor MotorGuide Service Dealers are responsible for damages to MotorGuide products due to repairs performed by anyone other than an Authorized MotorGuide Service Dealer. Neither MotorGuide nor Mercury Marine is responsible for failure or damage caused by improper installation, set-up, preparation, or previous service or repair errors.
4. For commercial use and government use customers, MotorGuide electric trolling motors are warranted to the original retail purchaser to be free from defects in material or workmanship for one (1) year. Commercial use is defined as any work or employment-related use of the product, or any use of the product which generates income, for any part of the warranty period, even if the product is only occasionally used for such purpose such as Rental Fleets, Guides, Fish Camps or similar operations. Warranty is not transferable to any subsequent purchaser. The Mercury Product Protection plan is not available to commercial use or government use customers.
5. MotorGuide Composite Shaft Limited Lifetime Warranty. MotorGuide composite shafts are warranted to the original retail purchaser to be free of defects in material or workmanship for the lifetime of the original purchaser. MotorGuide will provide a new composite shaft at no cost for any composite shaft which contains a defect in material or workmanship. The installation costs are the sole responsibility of the purchaser.
6. Warranty coverage is available to customers that purchase from an authorized Dealer or Retailer that is authorized by MotorGuide Marine to distribute the product in the country in which the sale occurred. Warranty coverage and duration varies by the country in which the owner resides. This warranty applies to MotorGuide Trolling Motors sold and used in the United States. This Limited Warranty begins on the date the product is first sold to a purchaser or the date on which the product is first put into service, whichever occurs first. MotorGuide Accessories are covered by this Limited Warranty for a coverage period of one (1) year from the date of retail sale. The repair or replacement of parts, or the performance of service under this warranty, does not extend the life of this warranty beyond its original expiration date. Promotional warranties are not included in this statement and coverage may vary by promotion. Product either sold or put into service more than six years from date of manufacture is excluded from warranty coverage.

7. This warranty does not apply to normal worn parts, for example, worn cables, adjustments, or product damage due to; 1) neglect, lack of maintenance, accident, abnormal operation or improper installation or service; 2) abuse, such as, bent metal columns, bent armature shafts, broken control cables, etc., accidents, modifications, misuse, excessive wear or damage caused by an owner's failure to provide reasonable and necessary installation or care; 3) use of an accessory or part not manufactured by MotorGuide or Mercury; 4) alteration or removal of parts; 5) opening the lower unit (motor) by anyone other than an authorized MotorGuide Service Center will void this warranty.
8. We reserve the right to improve the design of any Trolling Motor without assuming any obligation to modify any Trolling Motor previously manufactured.
9. All Serialized "Service-Repair" trolling motors receive a (1) one year warranty. Non-serialized "Service-Repair" electric trolling motors are NOT warranted. "Service-Repair" motor denotes a trolling motor sold by MotorGuide that may be used but has been inspected and may have had minor repairs. Original retail purchaser of a "Service-Repair" motor is the first purchaser of the motor after it is denoted as "Service-Repair". "Service Repair" motors have a blue sticker on the battery cable and box denoting "Manufacturer Certified Service Repair Motor".
10. This warranty will not apply to 1) haul out, launch, towing and storage, transportation charges and/or travel time, telephone or rental charges of any type, inconvenience, or loss of time or income, or other consequential damages; or 2) removal or replacement of boat partitions or material because of boat design for necessary access to the Product; or 3) disconnection and reconnection of hard-wired trolling motors.
11. TERMINATION OF COVERAGE: Warranty coverage may be terminated for repossessed product, or product purchased at auction, from a salvage yard, from a liquidator, from an insurance company, from unauthorized marine dealers or boat builders, or other third party entities.
12. ALL INCIDENTAL OR CONSEQUENTIAL DAMAGES ARE EXCLUDED FROM THIS WARRANTY, WARRANTIES OF MERCHANTABILITY AND FITNESS ARE EXCLUDED FROM THIS WARRANTY, IMPLIED WARRANTIES ARE LIMITED TO THE LIFE OF THIS WARRANTY. SOME STATES DO NOT ALLOW LIMITATIONS ON HOW LONG AN IMPLIED WARRANTY LASTS OR THE EXCLUSION OR LIMITATION OF INCIDENTAL OR CONSEQUENTIAL DAMAGES, SO THE ABOVE LIMITATIONS OR EXCLUSIONS MAY NOT APPLY TO YOU. THIS WARRANTY GIVES YOU SPECIFIC LEGAL RIGHTS, AND YOU MAY ALSO HAVE OTHER LEGAL RIGHTS WHICH MAY VARY FROM STATE TO STATE.

For Your Records:

Model Number \_\_\_\_\_

Serial Number \_\_\_\_\_

## Notes:



## Section 2 - General Information

### Table of Contents

---

Recording Serial Number.....	6	While You Are Trolling .....	7
Transom Mount .....	6	While the Boat Is Stationary .....	8
Bow Mount .....	7	Passenger Safety Message.....	8
Boater's Responsibilities.....	7	Safe Boating Suggestions.....	8
Protecting People in the Water.....	7		

---

## Recording Serial Number

Record the serial number for future reference. For warranty purposes, complete the enclosed warranty card or register your trolling motor at [www.motorguide.com](http://www.motorguide.com).

## Transom Mount

The transom mount serial number decals are located underneath the transom mount and on the motor shaft.

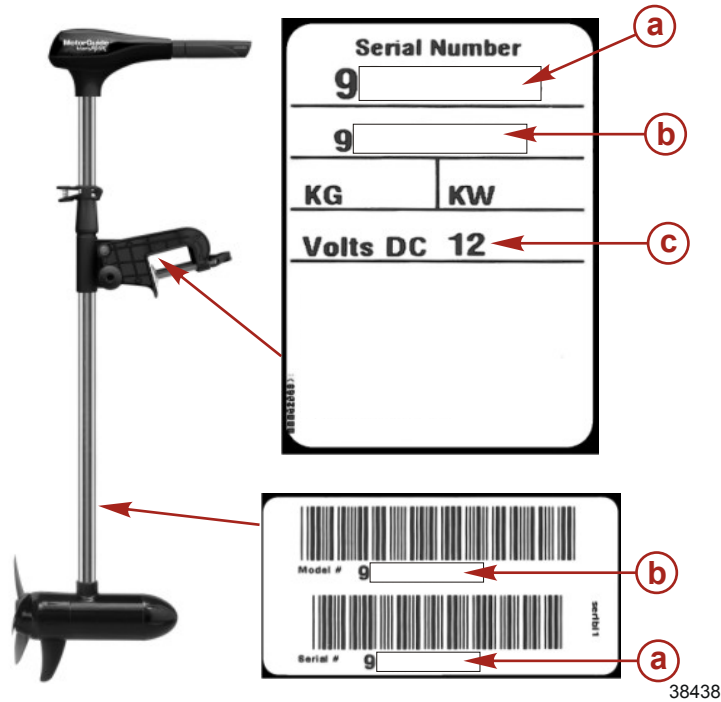

- a** - Serial number
- b** - Model identification number
- c** - Voltage

## Bow Mount

The bow mount and pontoon mount serial number decals are located on the friction tube and on the motor shaft.

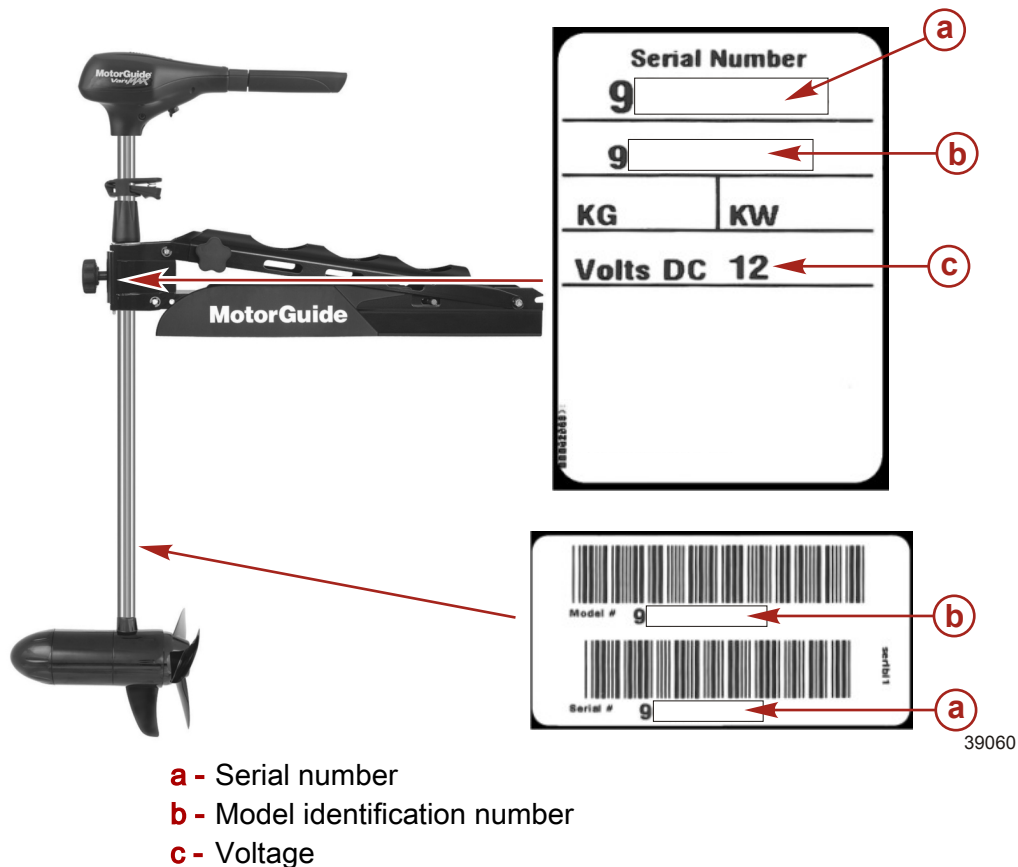

## Boater's Responsibilities

The operator (driver) is responsible for the correct and safe operation of the boat and safety of its occupants and general public. It is strongly recommended that each operator (driver) read and understand this entire manual before operating the trolling motor.

Be sure at least one additional person on board is instructed in the basic operation of the trolling motor in case the driver is unable to operate the boat.

## Protecting People in the Water

### While You Are Trolling

It is very difficult for a person in the water to take quick action to avoid a boat heading in their direction, even at slow speeds.



Always slow down and exercise extreme caution any time you are boating in an area where there might be people in the water.

## While the Boat Is Stationary

### WARNING

A spinning propeller, a moving boat, or any solid device attached to the boat can cause serious injury or death to swimmers. Stop the trolling motor immediately whenever anyone in the water is near your boat.

Shut off the trolling motor before allowing people to swim or be in the water near your boat.

## Passenger Safety Message

Whenever the boat is in motion, observe the location of all passengers. A sudden reduction in boat speed, such as a sharp change of boat direction, could throw them off the boat.

## Safe Boating Suggestions

In order to safely enjoy the waterways, familiarize yourself with local and other governmental boating regulations and restrictions, and consider the following suggestions.

**Use flotation devices.** It is the law to have an approved personal flotation device of suitable size for each person aboard and have it readily accessible.

**Do not overload your boat.** Most boats are rated and certified for maximum load (weight) capacities, refer to your boat capacity plate. If in doubt, contact your dealer or the boat's manufacturer.

**Perform safety checks and required maintenance.** Follow a regular schedule and ensure all repairs are made properly.

**Never be under the influence of alcohol or drugs while boating (it is the law).** Alcohol or drug use impairs your judgment and greatly reduces your ability to react quickly.

**Passenger boarding.** Stop the trolling motor whenever passengers are boarding or unloading.

**Be alert.** The operator of the boat is responsible by law to maintain a proper lookout by sight and hearing. The operator must have an unobstructed view particularly to the front. No passengers, load, or fishing seats should block the operators view when operating the boat.

**Underwater hazards.** Reduce speed and proceed with caution whenever navigating in shallow water.

**Tripping hazards.** To avoid a trip hazard, route all cables and wiring neatly and out of the way.

**Report accidents.** Boat operators are required by law to file a Boating Accident Report with their state boating law enforcement agency when their boat is involved in certain boating accidents. A boating accident must be reported if 1) there is loss of life or probable loss of life, 2) there is personal injury requiring medical treatment beyond first aid, 3) there is damage to boats or other property where the damage value exceeds \$500.00 or 4) there is complete loss of the boat. Seek further assistance from local law enforcement.

# Section 3 - Product Overview and Assembly

## Table of Contents

---

Component Identification.....	10	Attaching the Handle.....	12
VariMAX Transom Mount .....	10	Extending and Retracting the Handle.....	13
VariMAX Bow Mount .....	11	Installing the Propeller.....	14

---

## Component Identification

### VariMAX Transom Mount

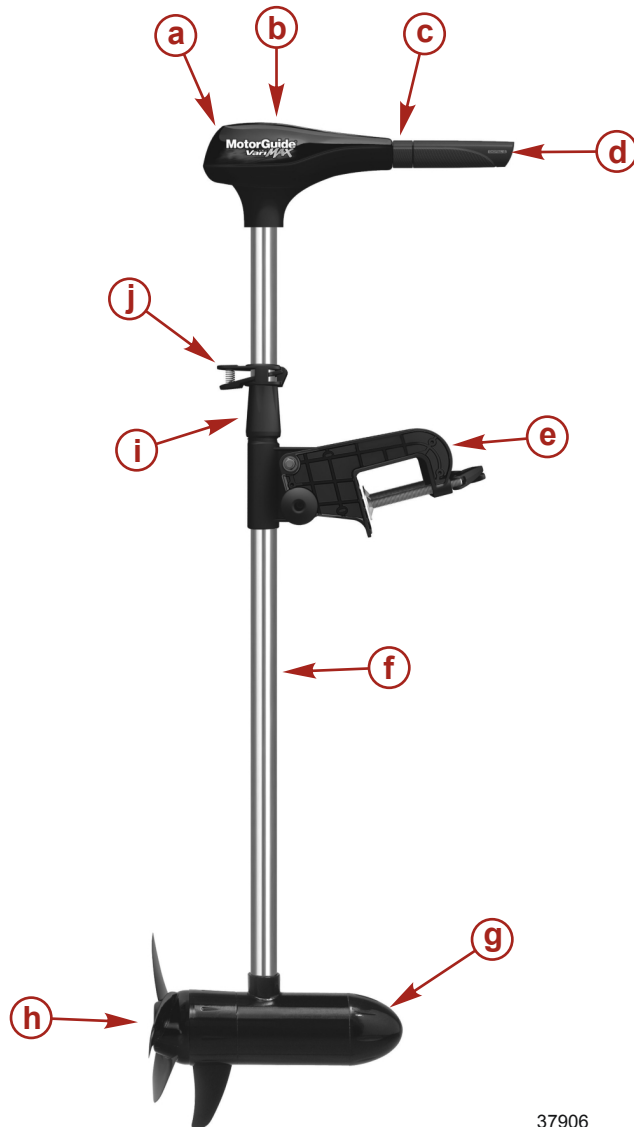

37906

- |  |                                    |
|--|------------------------------------|
| <b>a</b> - Top housing                           | <b>f</b> - Shaft                   |
| <b>b</b> - BluVis function display               | <b>g</b> - Lower unit              |
| <b>c</b> - Cam-lock                              | <b>h</b> - Propeller               |
| <b>d</b> - Push-pull direction and speed control | <b>i</b> - Steering tension collar |
| <b>e</b> - Taper-lock mount                      | <b>j</b> - One-touch depth collar  |

## VariMAX Bow Mount

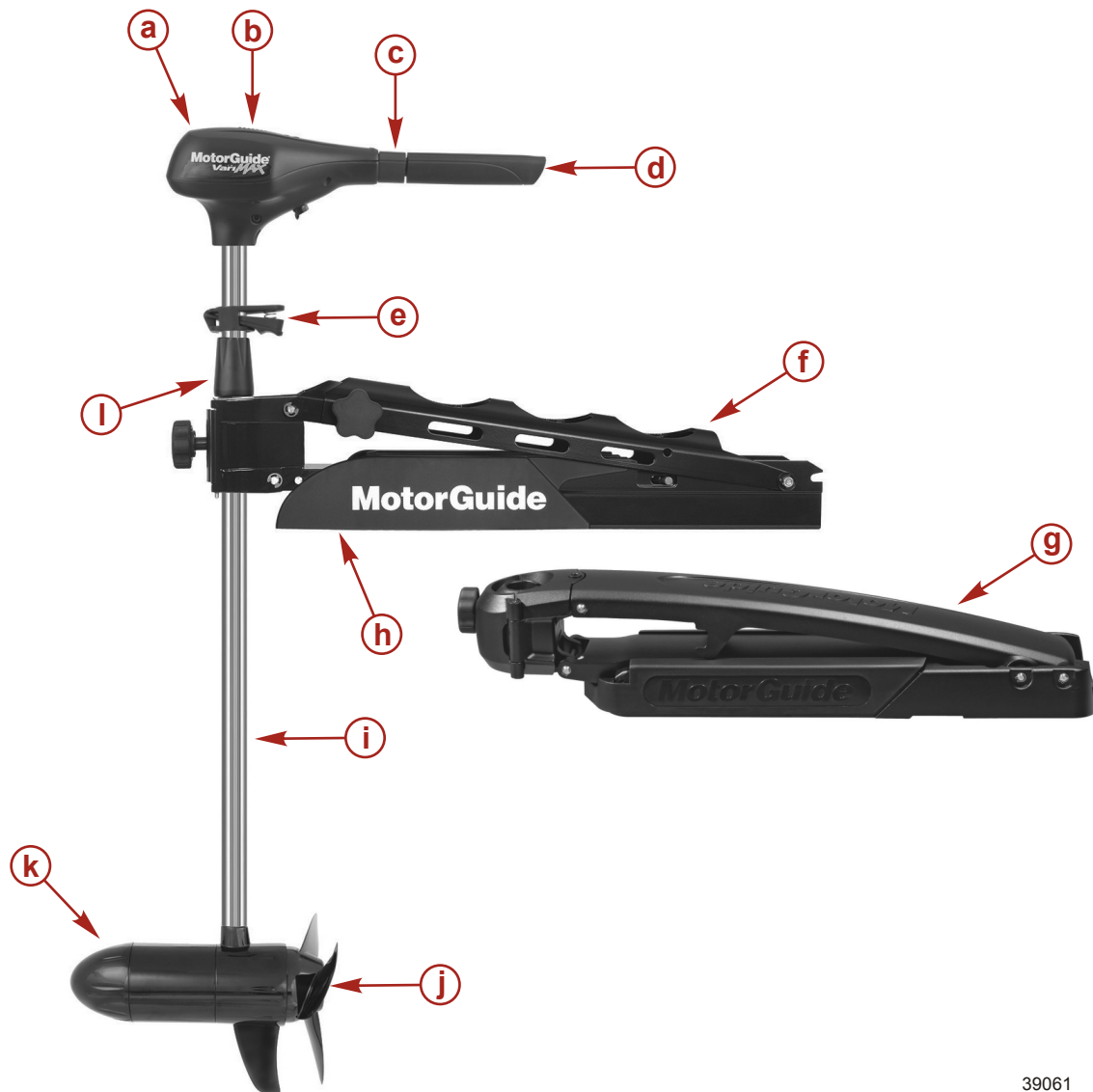

39061

- |  |                                    |
|--|------------------------------------|
| <b>a</b> - Top housing                           | <b>g</b> - Gator Flex 360          |
| <b>b</b> - BluVis function display               | <b>h</b> - Decket                  |
| <b>c</b> - Cam-lock                              | <b>i</b> - Shaft                   |
| <b>d</b> - Push-pull direction and speed control | <b>j</b> - Propeller               |
| <b>e</b> - One-touch depth collar                | <b>k</b> - Lower unit              |
| <b>f</b> - Gator 20.8 Breakaway                  | <b>l</b> - Steering tension collar |

## Attaching the Handle

**NOTE:** For proper installation, assemble the trolling motor on a flat, level surface.

1. Ensure the battery cables are disconnected from the power source.
2. Align the tri-lobe handle to the top housing using the flat groove on the extension handle. The handle extension spring should face up.

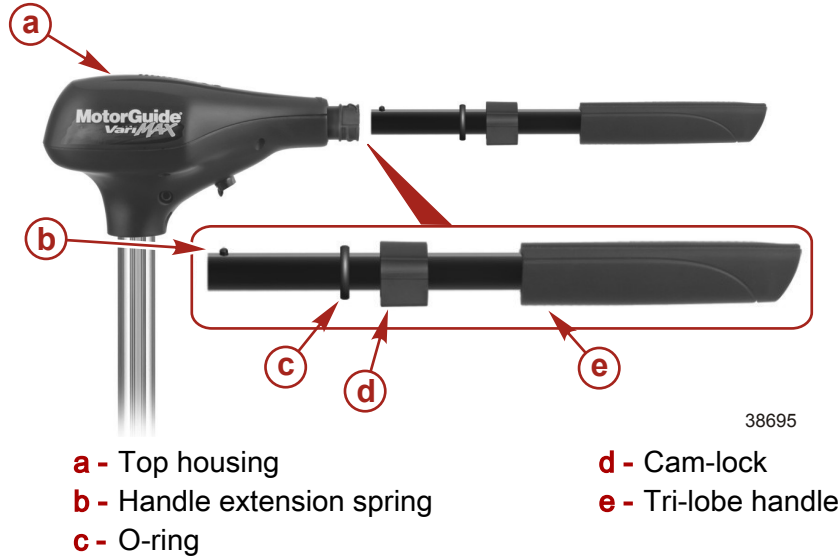

3. Press the handle extension spring while inserting the handle into the top housing. Adjust the handle to the desired length.

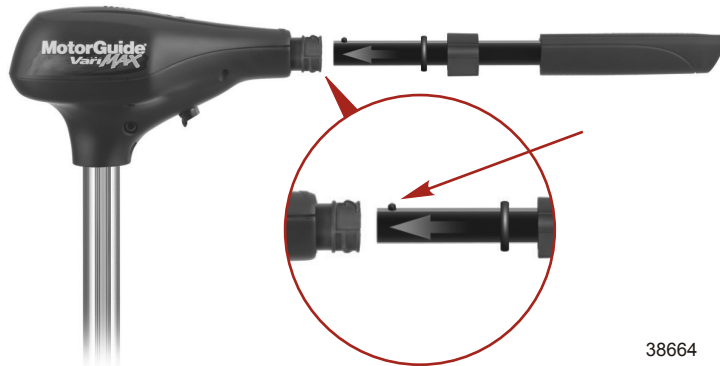

Handle extension spring

4. After the tri-lobe handle engages, move the O-ring flush against the top housing.

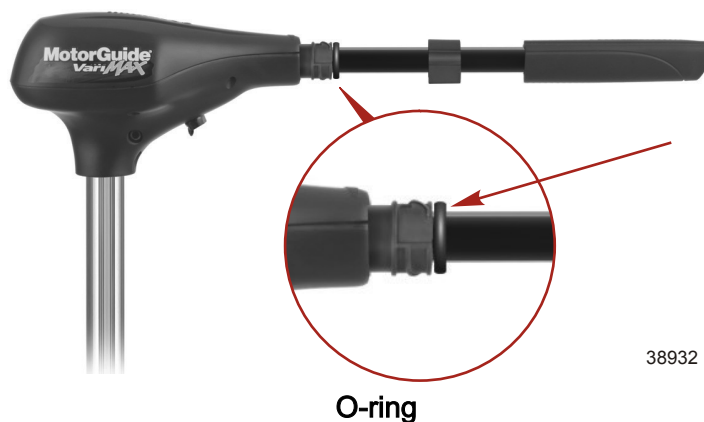

O-ring



5. Rotate the cam-lock clockwise 180°. Move the cam-lock flush against the top housing.



6. To secure the tri-lobe handle, hold the handle steady while rotating and tightening the cam-lock clockwise 180°. Verify that the handle, cam-lock, and top housing are in alignment.

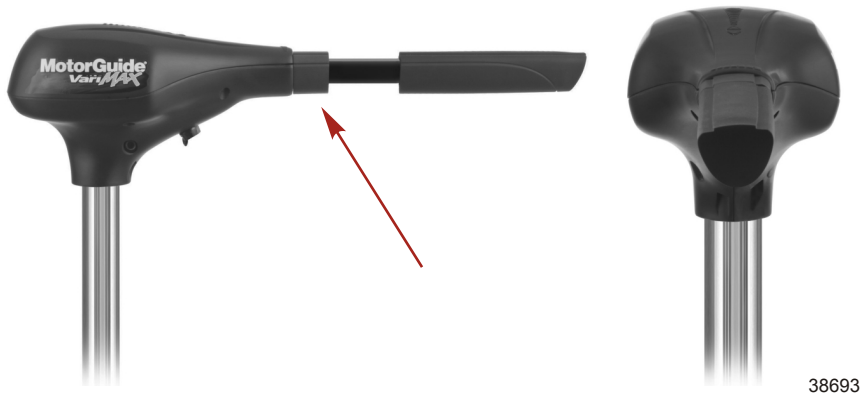

Cam-lock and top housing in alignment

## Extending and Retracting the Handle

1. Firmly grasp the tri-lobe handle, then rotate and loosen the cam-lock counter clockwise 180°.



2. Extend or retract the handle to the desired length.



Extending handle



Retracting handle

3. To secure the tri-lobe handle, hold the handle steady while rotating and tightening the cam-lock clockwise 180°. Verify that the handle, cam-lock, and top housing are in alignment.

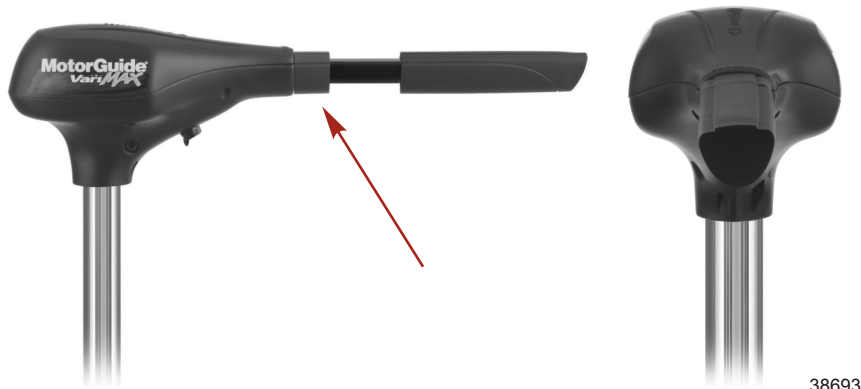

Cam-lock and top housing in alignment

## Installing the Propeller

### ⚠ WARNING

Performing service or maintenance without first disconnecting the battery can cause product damage, personal injury, or death due to fire, explosion, electrical shock, or unexpected motor starting. Always disconnect the battery cables from the battery before maintaining, servicing, installing, or removing motor components.

1. Rotate the motor shaft to insert the propeller pin horizontally.



Propeller pin

2. Install the propeller onto the motor shaft by engaging the propeller onto the propeller pin.



3. Install the propeller nut. Tighten securely.



4. Use a MotorGuide propeller wrench or pliers to tighten the propeller nut another ¼ turn.

Recommended MotorGuide Accessory Description	Part Number
MotorGuide Prop Wrench Kit	MGA050B6

## Notes:

# Section 4 - Wiring and Battery Information

## Table of Contents

---

Battery Precautions.....	18	Battery Connection.....	19
Standard Practices And Procedures.....	18	12-Volt Battery Connection .....	20
Battery Recommendations.....	18	24-Volt Battery Connection .....	21
BluVis Battery Voltage Indicator.....	19		

---

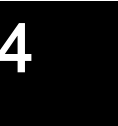

## Battery Precautions

### ⚠ WARNING

**An operating or charging battery produces gas that can ignite and explode, spraying out sulfuric acid, which can cause severe burns. Ventilate the area around the battery and wear protective equipment when handling or servicing batteries.**

When charging batteries, an explosive gas mixture forms in each cell. Part of this gas escapes through holes in vent plugs and may form an explosive atmosphere around battery if ventilation is poor. This explosive gas may remain in or around battery for several hours after it has been charged. Sparks or flames can ignite this gas and cause an internal explosion which may shatter the battery.

The following precautions should be observed to prevent an explosion:

1. Do not smoke near batteries being charged or which have been charged very recently.
2. Do not break live circuits at terminals of batteries because a spark usually occurs at the point where a live circuit is broken. Always be careful when connecting or disconnecting cable clamps on chargers. Poor connections are a common cause of electrical arcs which cause explosions.
3. Do not reverse polarity of battery terminal to cable connections.

## Standard Practices And Procedures

- Do not use the main engine battery to power the trolling motor.
- Disconnect the trolling motor from the battery when charging and after each use.
- Route the trolling motor wires on the opposite side of the boat from other miscellaneous boat wiring.
- Connect boat accessories directly to the main engine battery.

## Battery Recommendations

- Use a 12-volt, deep cycle marine battery. Refer to **Battery Connection**.
- Install a 50-amp manual reset circuit breaker in line with the trolling motor positive leads within 180 cm (72 in.) of the batteries.
- Use 13 mm (6-gauge) battery cables if extending the existing wire beyond the standard battery cable.

Recommended MotorGuide Accessory Description	Part Number
Trolling Motor Power Plug	8M4000953
Trolling Motor SP (receptacle)	8M4000954
50-Amp Alligator Clips	8M4000287
6-Gauge Battery Cable and Terminals With 50-Amp Manual Reset Breaker	MM309922T
50-Amp Manual Reset Breaker	MM5870

## BluVis Battery Voltage Indicator

Use the BluVis function display to determine battery voltage level. The battery indicator will display the voltage for three seconds when the motor is connected to the battery and when the speed control is turned off. Refer to the diagram below to reference remaining battery voltage for 12- and 24-volt battery connections.

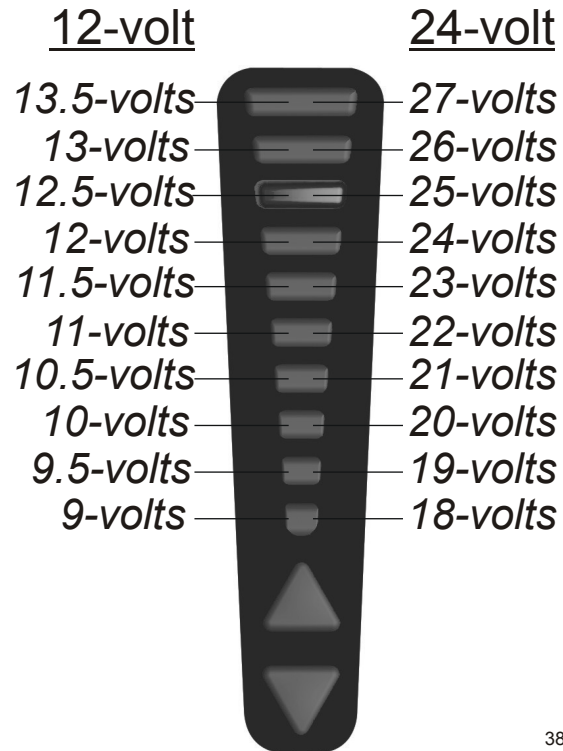

38890

## Battery Connection

**⚠ CAUTION**

Disconnecting or connecting the battery cables in the incorrect order can cause injury from electrical shock or can damage the electrical system. Always disconnect the negative (-) battery cable first and connect it last.

### 12-Volt Battery Connection

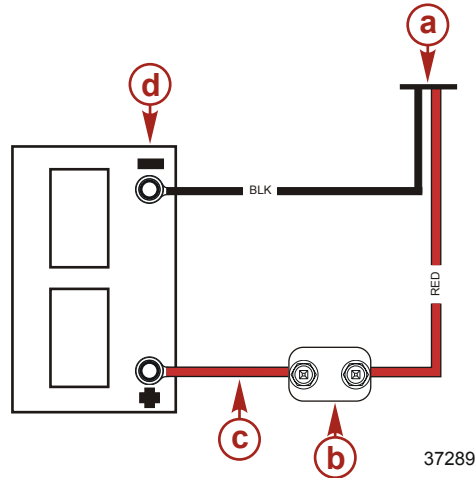

- a** - Power cable
- b** - 50-amp circuit breaker
- c** - Jumper wire
- d** - Common ground

1. Install a 50-amp circuit breaker (not included) in line with the positive lead.
2. Connect the red battery lead from the power cable to the positive (+) battery post.
3. Connect the black battery lead from the power cable to the negative (-) battery post.

Recommended MotorGuide Accessory Description	Part Number
50-Amp Manual Reset Breaker	MM5870



## 24-Volt Battery Connection

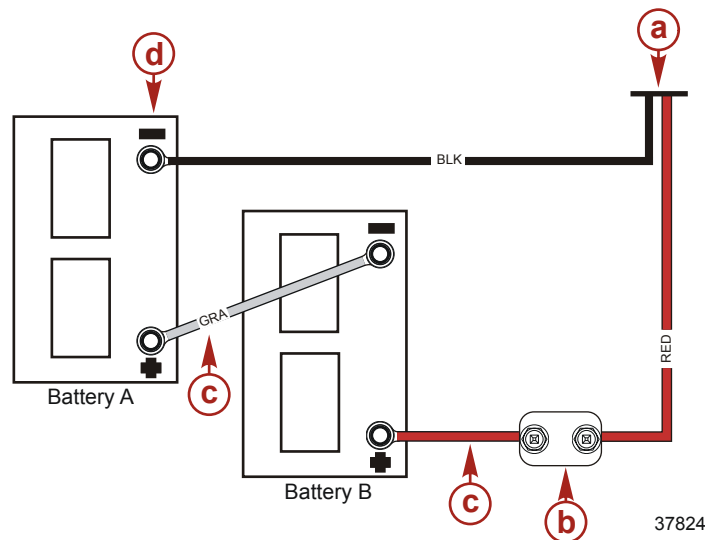

- a** - Power cable  
**b** - 50-amp circuit breaker  
**c** - Jumper wire  
**d** - Common ground

1. Install a 50-amp circuit breaker (not included) in line with the positive lead.
2. Connect the red battery lead from the power cable to the positive (+) post on battery B.
3. Connect the black battery lead from the power cable to the negative (-) post on Battery A.
4. Connect a jumper wire between the negative (-) post on Battery B to the positive (+) post on battery A.

Recommended MotorGuide Accessory Description	Part Number
50-Amp Manual Reset Breaker	MM5870

## Notes:

# Section 5 - Mount Installation

## Table of Contents

---

VariMAX Transom Mount Installation.....	24	Gator 20.8 Breakaway Installation.....	25
Pontoon Mount Installation.....	24	Gator Flex 360.....	26

---

## VariMAX Transom Mount Installation

**NOTE:** Fits transoms up to 8.25 cm (3.25 in.) thick.

1. Select an appropriate area on the transom of the boat to install the mount.
2. Retract the transom clamp screws.
3. Place the transom mount over the transom of the boat. Ensure the mount is secure.



**IMPORTANT:** Overtightening the transom clamp screws can weaken or damage the mount bracket.

4. Tighten the transom clamp screws securely.

## Pontoon Mount Installation

**IMPORTANT:** Choose an area on the deck with a 2.5 cm (1 in.) clearance from the bow of the boat for all motor positions including run and stow positions.

1. Select an appropriate area on the deck of the boat to install the mount.

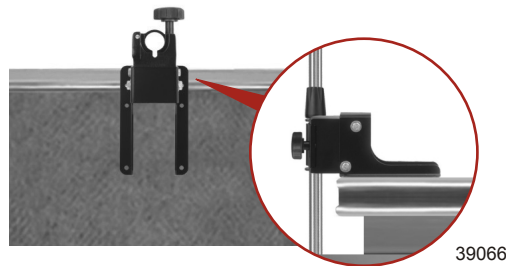

2. Place the pontoon mount base on the surface of the boat deck. Use the mount base as a template to mark the location of the mount holes.

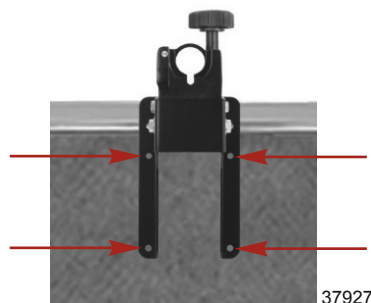

Pontoon mount holes

**IMPORTANT:** Using a larger drill bit, countersink the holes on fiberglass boats to prevent the gel-coat from cracking.

3. Drill the mounting holes with a 7 mm (1/4 in.) diameter drill bit. Remove any debris.
4. Install four stainless steel washers and locking nuts onto the mounting screws underneath the boat deck. Tighten securely.

## Gator 20.8 Breakaway Installation



37805

**Gator 20.8 Breakaway**

**IMPORTANT:** Choose an area on the deck with a 7.6 cm (3 in.) clearance from the bow of the boat for all motor positions including run and stow positions.

1. Select an appropriate area on the deck of the boat to install the mount. Ensure that the forward mounting screws will not penetrate the hull.

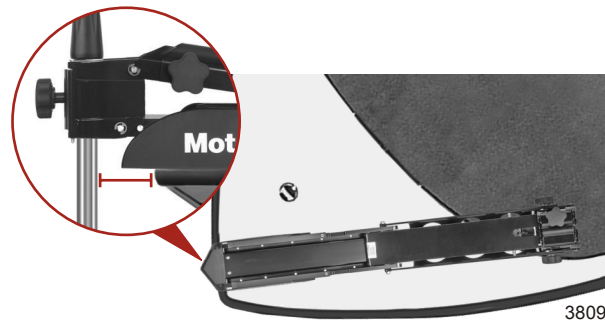

38094

**Mount on deck**

2. Place the bow mount base on the surface of the boat deck. Use the mount base as a template to mark the locations of the front mounting holes in the plastic deck and the rear mounting holes on the mount base.

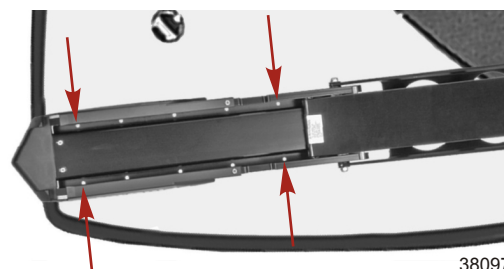

38097

**Mount base mounting holes**

3. Drill the mounting holes with a 7 mm (1/4 in.) diameter drill bit. Remove any debris.
4. Re-drill each mounting hole with a 13 mm (1/2 in.) diameter drill bit.

**IMPORTANT:** Using a larger drill bit, countersink the holes on fiberglass boats to prevent cracking.

5. Insert the rubber mounting isolators into the drilled holes. Position the isolators in-line with the mount base with the wider side toward the outside of the mount bracket.

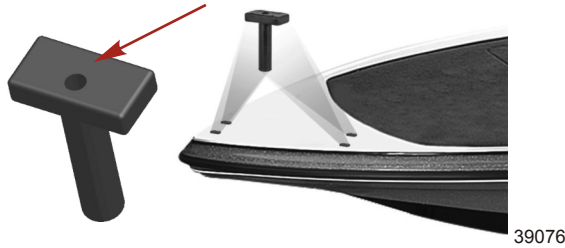

6. Place the mount bracket on the isolators and align the holes. Install the two longer screws into the front mounting holes and the two shorter screws into the rear mounting holes. Tighten all of the mounting screws securely with a Phillips screwdriver.

**IMPORTANT: The bracket must lay flush against the isolators before bolted to the deck or the mount will bind, making it difficult or impossible to unlatch.**

7. Once installed, the bracket should fasten securely and evenly, with the latch pins in the latch, and release with a light, quick snap of the rope handle.

## Gator Flex 360



Gator Flex 360

**IMPORTANT: Choose an area on the deck with a 7.6 cm (3 in.) clearance from the bow of the boat for all motor positions including run and stow positions.**

1. Select an appropriate area on the deck of the boat to install the mount. Ensure that the forward mounting screws will not penetrate the hull.



Mount on deck

2. Place the bow mount base on the surface of the boat deck. Use the mount base as a template to mark the locations of the front mounting holes in the plastic decket and the rear mounting holes on the mount base.

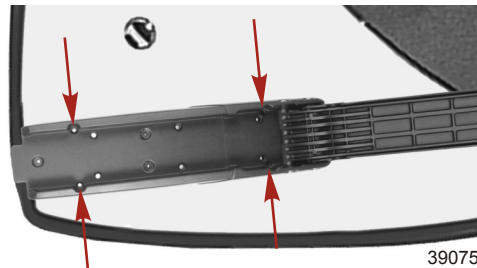

**Mount base mounting holes**

3. Drill the mounting holes with a 7 mm (1/4 in.) diameter drill bit. Remove any debris.  
**IMPORTANT: Using a larger drill bit, countersink the holes on fiberglass boats to prevent cracking.**
4. Insert the rubber washers between the base of the mount and the boat mounting surface. Install the steel washers and nylon locking nuts onto the mounting screws underneath the boat deck. Tighten securely with a Phillips screwdriver and 11 mm (7/16 in.) wrench.  
**IMPORTANT: If necessary, shim the rubber washers with 25 mm (1 in.) stainless steel washers to create a level mounting surface.**
5. Once installed, the bracket should fasten securely and evenly, with the latch pins in the latch, and release with a light, easy pull on the rope handle.
6. Using a Phillips screwdriver and the decket screws, secure the decket to the mount base.

## Notes:



# Section 6 - Operation

## Table of Contents

Installing The Motor Into The Bow Mount.....	30	Adjusting The Steering Tension.....	35
Removing The Motor From The Bow Mount.....	30	Adjusting The Motor Depth.....	35
Stowing The Trolling Motor.....	30	Speed Control.....	36
Transom Mount .....	30	Direction Control.....	36
Bow Mount .....	32	Transom Mount Application .....	37
Deploying The Trolling Motor.....	33	Transom Mount—Backtrolling Application	
Transom Mount .....	33	.....	37
Bow Mount .....	34	Bow Mount Application .....	37

## Installing The Motor Into The Bow Mount

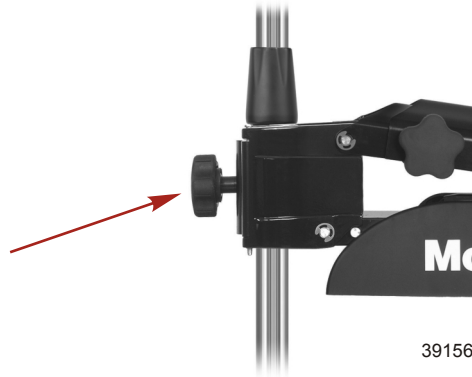

Bracket door knob

1. Turn the bracket door knob counter clockwise to loosen and open the bracket door.
2. Place the motor column into the bracket and close the door.
3. Turn the bracket door knob clockwise to tighten the motor column in the bracket.

## Removing The Motor From The Bow Mount

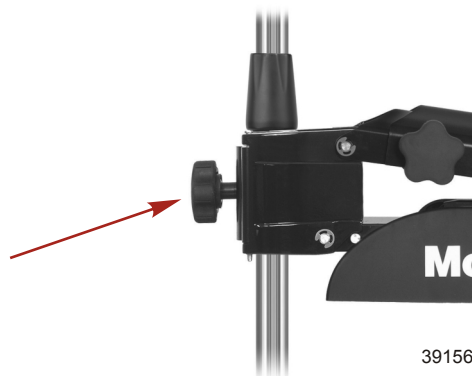

Bracket door knob

1. Turn the bracket door knob counter clockwise to loosen and open the bracket door.
2. Remove the motor column from the bracket and close the door.

## Stowing The Trolling Motor

### ⚠ WARNING

Rotating propellers can cause serious injury or death. Never start or operate the motor out of water.

### ⚠ CAUTION

Moving parts, such as hinges and pivot points, can cause serious injury. Keep away from moving parts when stowing, deploying, or tilting the motor.

## Transom Mount

**IMPORTANT:** Ensure the mount is stowed while using the main engine or trailering the boat. Ensure the steering tension collar is tightened securely.

**NOTE:** The mount orientation of the motor determines the functionality of the taper-lock knob. Push or pull the taper-lock knob to release the taper-lock pin.

1. Firmly grasp the column and push–or–pull–the taper-lock knob.



**Taper-lock knob**

**IMPORTANT:** Do not use the handle to stow or tilt the motor.

2. Tilt the motor toward you by pulling back on the column while simultaneously pushing–or–pulling–the taper-lock knob.



**Taper-lock knob**

3. Once the motor is stowed, release the taper-lock knob. Verify the taper-lock pin is securely engaged by pushing–or–pulling–on the taper-lock knob.



**Taper-lock knob**

4. Secure the motor by moving the depth collar flush against the steering tension collar.

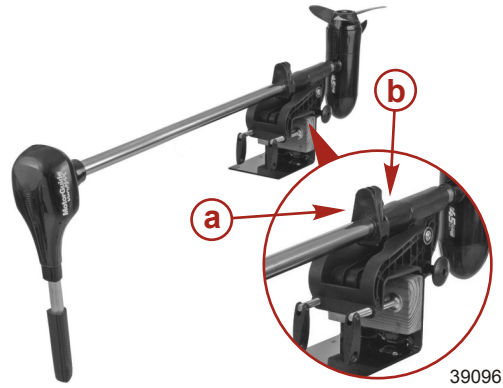

- a - Depth collar
- b - Steering tension collar

## Bow Mount

**NOTE:** This bow mount stowing procedure applies to both the Gator 20.8 Breakaway mount (pictured) and the Gator Flex 360 mount.

1. Firmly grasp the mount rope handle.
2. Snap the mount rope handle to disengage the lock pin.
3. Continue to pull the mount rope handle to raise the lower unit onto the mount.



Mount rope

**IMPORTANT:** Gently raise the trolling motor out of the water. Do not release the mount rope handle until the lock pin is engaged.

4. Once the motor is in the stow position, the lock pin engages to secure the trolling motor.

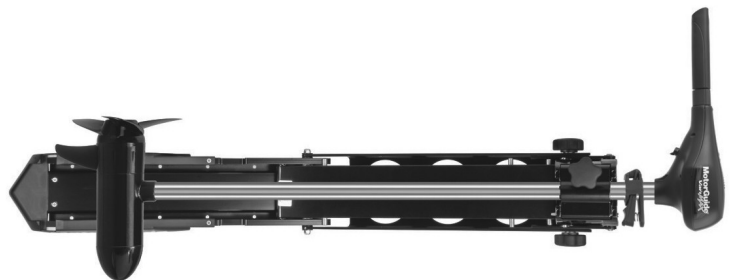

VariMAX stowed

## Deploying The Trolling Motor

### ⚠ WARNING

Rotating propellers can cause serious injury or death. Never start or operate the motor out of water.

### ⚠ CAUTION

Moving parts, such as hinges and pivot points, can cause serious injury. Keep away from moving parts when stowing, deploying, or tilting the motor.

### Transom Mount

**NOTE:** The mount orientation of the motor determines the functionality of the taper-lock knob. Push or pull the taper-lock knob to release the taper-lock pin.

1. Firmly grasp the column and push—or pull—the taper-lock knob.

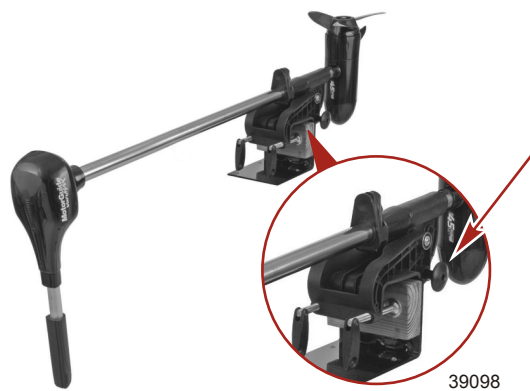

Taper-lock knob

**IMPORTANT:** Do not use the handle to tilt or deploy the motor.

2. Adjust the angle of the motor to the desired position while simultaneously pushing—or pulling—the taper-lock knob.



Taper-lock knob

3. Release the taper-lock knob. Verify that the taper-lock pin is securely engaged.



Taper-lock knob

4. Grasp the shaft with one hand and pinch the depth collar to lower the trolling motor to the desired depth.

**⚠ CAUTION**

Avoid possible serious injury from the motor dropping suddenly when adjusting the motor depth. Firmly grasp the motor shaft with one hand when raising or lowering the motor.

## Bow Mount

**NOTE:** This bow mount deploying procedure applies to both the Gator 20.8 Breakaway mount (pictured) and the Gator Flex 360 mount.

1. Firmly grasp the mount rope handle.
2. Snap the mount rope handle to disengage the lock pin.
3. Continue to pull the mount rope handle to lower the trolling motor into the water.

**IMPORTANT:** Gently lower the trolling motor into the water. Do not release the mount rope handle until the lock pin is engaged.

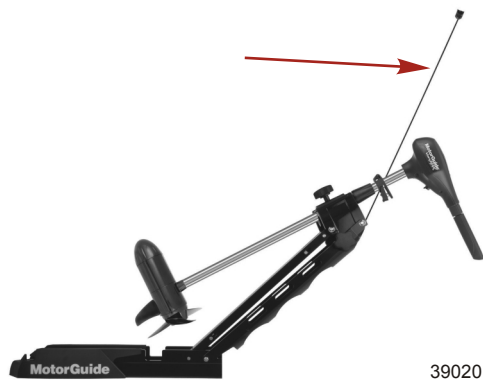

Mount rope

- Once the motor is in the deployed position, the lock pin will engage to secure the trolling motor.



VariMAX deployed

## Adjusting The Steering Tension

Adjust the steering tension collar to increase or decrease the effort to turn the motor freely.

- To fasten the column in a fixed position, turn the steering tension collar clockwise.
- To unfasten the column from a fixed position, turn the steering tension collar counterclockwise to reach the desired steering tension.

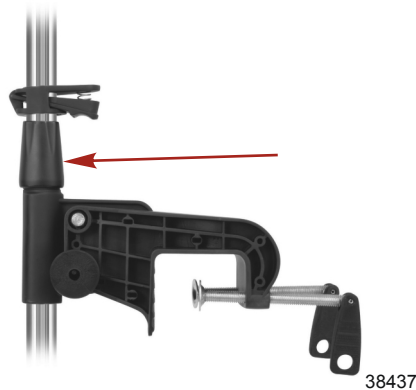

Steering tension collar

## Adjusting The Motor Depth

### ⚠ CAUTION

Avoid possible serious injury from dropping the motor when adjusting the motor depth. Firmly grasp the motor shaft with one hand when raising or lowering the motor.

Adjust the depth of the motor to improve trolling motor performance in various water depths. **IMPORTANT: When adjusting the motor depth, ensure the lower unit is fully submerged to avoid propeller cavitation.**

- Firmly grasp the column with one hand while holding the depth collar.
- Pinch the depth collar until the motor column slides freely.

3. Raise or lower to the desired depth.

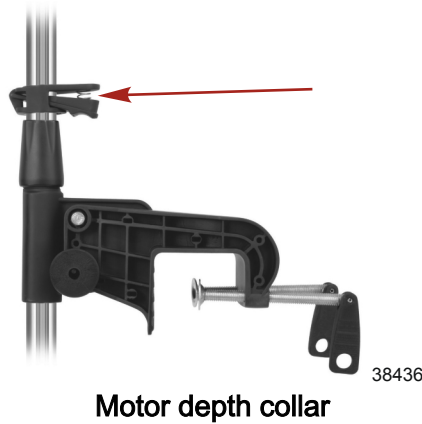

## Speed Control

MotorGuide VariMAX motors offer a new digital method of variable speed control that provides more efficient power consumption and precise speed control in 270° of handle rotation. VariMAX Digital variable speed control allows you to set the exact speed you want, whether in forward or reverse, for maximum control.

**NOTE:** Speed control is operable regardless of handle position. For top housing reorientation, refer to **Custom Applications**.

Rotate the handle clockwise to increase speed in both forward and reverse directions. The BluVis function display indicates speed-setting.

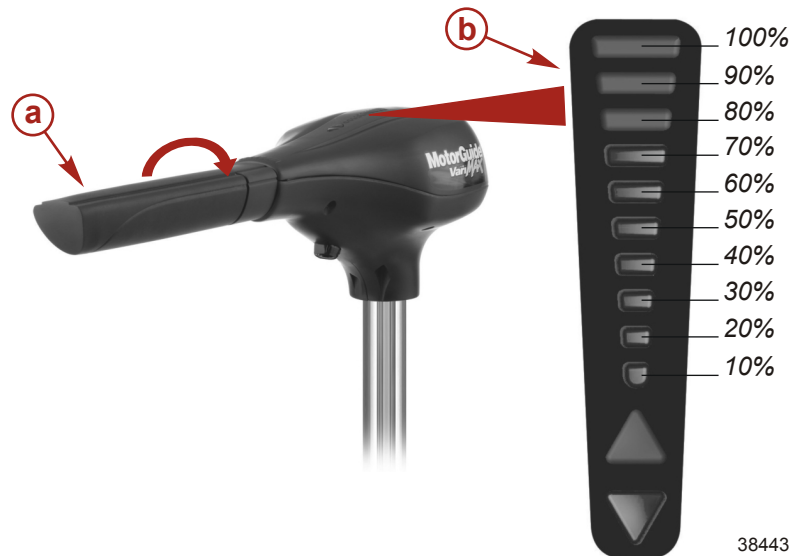

- a - Rotate the handle clockwise
- b - Bluvis function display with speed-settings

## Direction Control

The intuitive push-forward, pull-reverse direction control lets you increase the speed by turning the handle clockwise, whether in forward or reverse. To shift and change the direction of the propeller, simply pull back or push forward on the handle. The BluVis function display shows your relative speed setting and direction when the propeller is moving.



**IMPORTANT:** To shift the motor and change the direction of the propeller, the power must be below 50% to provide instant direction control for forward and reverse. The motor will only shift if below the 50% speed setting to protect the motor from damage.

### Transom Mount Application

To move the boat forward, pull the handle. To move the boat in reverse, push the handle. The BluVis function display indicates the motor direction.



### Transom Mount—Backtrolling Application

To use the transom mount for backtrolling, reverse the top housing position and toggle the direction control switch. Refer to **Custom Applications**.

To backtroll, push the handle. To reverse backtroll, pull the handle. The BluVis function display indicates the motor direction.

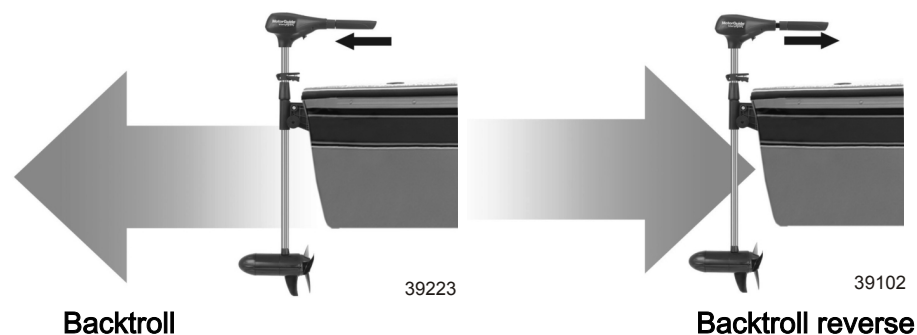

### Bow Mount Application

To move the boat forward, push the handle. To move the boat in reverse, pull the handle. The BluVis function display indicates the motor direction.

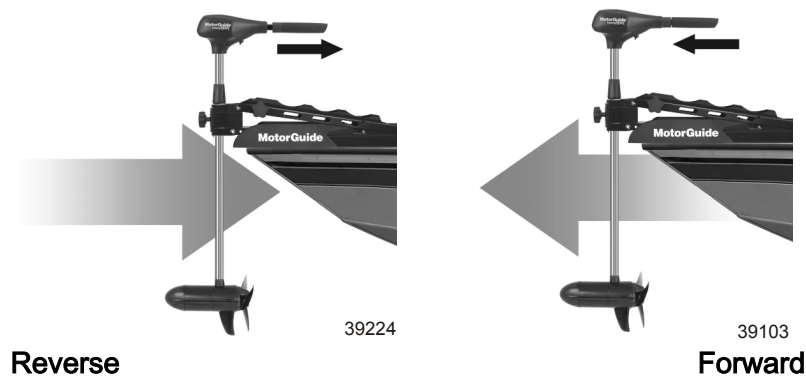

## Notes:

# Section 7 - Maintenance and Storage

## Table of Contents

---

Trolling Motor Care.....	40	Storage Preparation.....	40
SELECTING REPLACEMENT PARTS .....	40	Battery Inspection.....	41
Inspection And Maintenance Schedule.....	40	Propeller Replacement.....	41
Before Each Use .....	40	Removing The Propeller .....	41
After Each Use .....	40	Installing The Propeller .....	42
Every 100 Hours Of Use Or Annually .....	40		

---

## Trolling Motor Care

To keep your trolling motor in the best operating condition and retain its dependability, your trolling motor must receive periodic inspections and maintenance. Keep it maintained properly to ensure the safety of you and your passengers.

### ⚠ WARNING

Neglecting to inspect, maintain, or repair your trolling motor can result in product damage or serious injury or death. Do not perform maintenance or service on your trolling motor if you are not familiar with the correct service and safety procedures.

Record all maintenance performed and save maintenance work orders and receipts.

## SELECTING REPLACEMENT PARTS

Original MotorGuide Certified Tough replacement parts.

## Inspection And Maintenance Schedule

### Before Each Use

- Check the tightness of the battery lead connections.
- Visually inspect for loose or corroded wiring connections.
- Check the tightness of the propeller nut.
- Check the propeller blades for damage.

### After Each Use

- Disconnect the battery cables from the power source or unplug the motor from the boat.
- After each use, check the propeller and propeller shaft for debris such as weeds and fishing line. Remove all debris.
- Check the tightness of the propeller nut.
- Rinse the trolling motor with clean water to remove dirt and dust that may scratch the surface.

### Every 100 Hours Of Use Or Annually

- Periodically lubricate all the pivot points with a non-aerosol, non-solvent based lubricant.

**IMPORTANT: Never use an aerosol lubricant to grease or oil any part of the unit. Many aerosol lubricants contain harmful propellants that can cause damage to various parts of the trolling motor.**

Tube Ref No.	Description	Where Used	Part No.
 95	2-4-C with Teflon	Pivot points	92-802859A 1

- Check the tightness of bolts, nuts, and other fasteners.
- Inspect the battery. Refer to **Battery Inspection**.

## Storage Preparation

The major consideration in preparing your trolling motor for storage is to protect it from corrosion and damage caused by freezing of trapped water.

Refer to the **Maintenance - Inspection and Maintenance Schedule** section and complete the appropriate care instructions to prepare your trolling motor for storage. Store the trolling motor in a dry location where it will not be affected by temperatures below  $-29\text{ }^{\circ}\text{C}$  ( $-20\text{ }^{\circ}\text{F}$ ).

**IMPORTANT:** Trolling motors stored in temperatures below  $0\text{ }^{\circ}\text{C}$  ( $32\text{ }^{\circ}\text{F}$ ) should be operated slowly for a minimum of 15 minutes before going above 30% operation.

## Battery Inspection

The battery should be inspected at periodic intervals to ensure proper trolling motor operation.

**IMPORTANT:** Read the safety and maintenance instructions which accompany your battery.

1. Ensure that the battery is secured to the vessel.
2. Ensure that the battery cable terminals are clean, tight, and correctly installed. For installation instructions, refer to **Battery Connection**.
3. Ensure that the battery is equipped with a battery box to prevent accidental shorting of the battery terminals.

## Propeller Replacement

### ⚠ WARNING

Performing service or maintenance without first disconnecting the battery can cause product damage, personal injury, or death due to fire, explosion, electrical shock, or unexpected motor starting. Always disconnect the battery cables from the battery before maintaining, servicing, installing, or removing motor components.

### Removing The Propeller

1. Disconnect the battery cables from the power source.
2. While holding the propeller blade with one hand, use a propeller wrench or pliers to remove the propeller nut.

**IMPORTANT:** If the propeller cannot be removed easily, hold one blade and use a rubber mallet to lightly tap the back side of the opposite blade. If the propeller cannot be removed, refer to Troubleshooting.

**NOTE:** If the propeller pin is bent, replace the propeller pin.



Recommended MotorGuide Accessory Description	Part Number
MotorGuide Prop Wrench Kit	MGA050B6

## Installing The Propeller

1. Rotate the motor shaft to insert the propeller pin horizontally.



38630

**Propeller pin**

2. Install the propeller onto the motor shaft by engaging the propeller onto the propeller pin.



38538

3. Install the propeller nut. Tighten securely.



38536

4. Use a MotorGuide propeller wrench or pliers to tighten the propeller nut another ¼ turn.

Recommended MotorGuide Accessory Description	Part Number
MotorGuide Prop Wrench Kit	MGA050B6

# Section 8 - Custom Applications

## Table of Contents

---

Repositioning The Top Housing.....	44	Motor Control Wiring.....	46
Setting The Direction Control Switch.....	45		

---



## Repositioning The Top Housing

VariMAX transom mount motors are configured at the factory for use on the transom. We designed the VariMAX motors so the head could easily be reversed (eight head positions are available) to fit any application including bow, backroller or sideways pulling applications. The BluVis lights can also be reversed to keep the intuitive push-pull feel and control consistent. If you have a VariMAX bow mount or pontoon mount motor, it is already configured for bow mount applications.

**IMPORTANT:** While configuring the top housing to a new position, you can toggle the position switch for the appropriate mount application. Refer to **Setting The Direction Control Switch**.

1. Ensure the battery cables are disconnected from the power source.
2. Loosen the top housing retaining bolt with a 5 mm diameter Allen wrench. Do not fully remove the retaining bolt.

**IMPORTANT:** Do not fully remove the top housing retaining bolt or the retaining nut may fall out. Do not raise the top housing off of the column. Removing the top housing may disconnect the motor control wires. If the wires disconnect, refer to **Motor Control Wiring** for wire orientation.



Allen wrench

3. Raise the top housing until the height pin disengages.

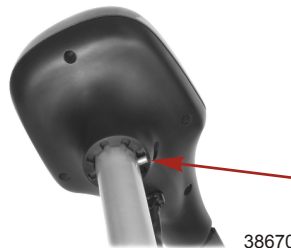

Height pin

4. Rotate the top housing to the desired position and push the top housing back down to engage the height pin.



- a - Top housing
- b - Eight position settings

5. Tighten the top housing retaining bolt with an Allen wrench. Tighten securely.



Torque Description	Nm	lb-in.	lb-ft
Top housing retaining bolt	8.5	75	–



38636

Allen wrench

## Setting The Direction Control Switch

VariMAX motors are configured to the intuitive push-pull direction control. To use the transom mount on the bow of the vessel, reverse the top housing and toggle the direction control switch to set the motor and BluVis function display orientation for a bow application. To reverse the top housing, refer to **Repositioning the Top Housing**.

1. Disconnect the battery cables from the power source.
2. Loosen the top housing retaining bolt with an Allen wrench. Do not fully remove the retaining bolt.

**IMPORTANT:** Do not fully remove the top housing retaining bolt or the retaining nut may fall out. Slowly raise the top housing off of the shaft ensuring that the motor control wires do not disconnect. If the wires are disconnected, refer to the Motor Control Wiring section for wire orientation.



38636

Allen wrench

3. Remove the top housing from the shaft.

**NOTE:** Do not remove the heat-sink grease on the motor shaft. Heat-sink grease will not wash out of clothing.

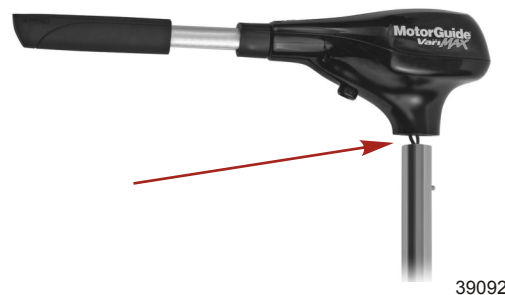

39092

Top housing removed from shaft

4. Rotate the top housing upside-down to expose the direction control switch inside.
5. Slide the switch away from the handle.

**NOTE:** If necessary, use a flathead screwdriver to slide the direction control switch.

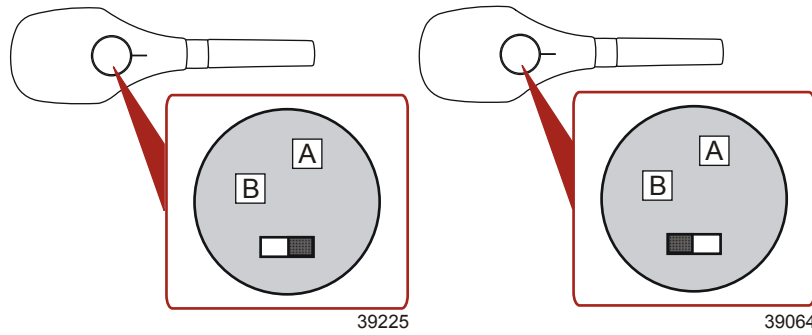

**Transom application (default)**

**Bow, pontoon or backtrolling application**

6. Replace the top housing onto the motor shaft.
7. Rotate the top housing to the desired position and push the top housing back down to engage the height pin.



- a** - Top housing
- b** - Eight position settings

8. Retighten the top housing retaining bolt with a Allen wrench. Tighten securely.

Torque Description	Nm	lb-in.	lb-ft
Top housing retaining bolt	8.5	75	-



Allen wrench

## Motor Control Wiring

### ⚠ WARNING

Performing service or maintenance without first disconnecting the battery can cause product damage, personal injury, or death due to fire, explosion, electrical shock, or unexpected motor starting. Always disconnect the battery cables from the battery before maintaining, servicing, installing, or removing motor components.

**IMPORTANT:** Disconnect the VariMAX motor control wiring for service only. Do not reconfigure the motor control wiring when reorienting the motor top housing between transom and bow applications.

**NOTE:** If necessary, use needle-nose pliers to connect the motor control wire to the respective terminal. Ensure the wiring connection is secure.

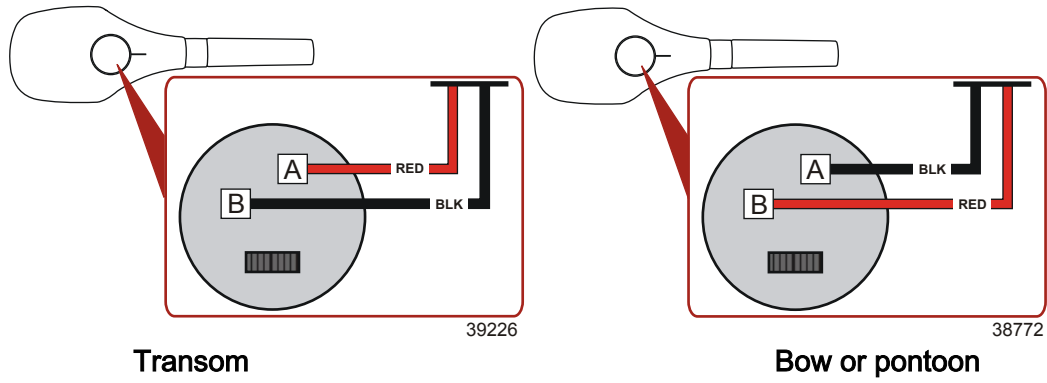

## Notes:

# Section 9 - Owner Service Assistance

## Table of Contents

---

Troubleshooting.....	50	Mercury Marine Service Offices.....	51
Service Assistance.....	50		

---

## Troubleshooting

**NOTE:** For service information, contact any certified MotorGuide Service Center. For a full listing of MotorGuide service centers, go to [www.motorguide.com](http://www.motorguide.com) or contact any Mercury Service office. Refer to **Owner Service Assistance**.

Symptom	Possible Cause	Resolution
Loss of power	Weak battery	Refer to <b>Wiring and Battery Information</b> .
	Loose or corroded battery connections	
	Propeller is loose, damaged or off-balance	Refer to <b>Maintenance</b> .
	Wiring or electrical connection faulty	Wire gauge from the battery to the trolling motor is insufficient. Six-gauge wire is recommended.
Excessive noise, vibration	Motor shaft is bent	Refer to <b>Service Center</b> .
	Propeller is loose, damaged or off-balance	Refer to <b>Maintenance</b> .
Motor failure (all speeds)	Weak battery	Refer to <b>Wiring and Battery Information</b> .
	Loose or corroded battery connections	
	Wiring or electrical connection faulty.	
	Electrical	Check the connector for a loose or damaged connection. Refer to <b>Wiring and Battery Information</b> .
	Fuse on circuit breaker is open	Replace the fuse or reset the circuit breaker only after determining the root cause of the problem.
Motor rotates in the wrong direction	Direction control switch in wrong position	Refer to <b>Assembly</b> .
BluVis function display failure	Electrical	Refer to <b>Service Center</b> .
	Wiring or electrical connection faulty	Check the battery connection. Refer to <b>Wiring and Battery Information</b> .
Difficulty removing propeller	Bent propeller pin	Hold one blade and lightly tap the opposite blade with a rubber mallet. Use a putty knife on both sides of the propeller to apply equal pressure.
	Bent armature shaft	Refer to <b>Service Center</b> .

## Service Assistance

Your satisfaction with your product is very important to us. If you have a problem or question about your motor, contact your dealer or any certified MotorGuide Service Center. For more service assistance information, refer to **Warranty Information**.

The following information will be needed by the service office:

- Your name and address
- Daytime telephone number
- Model and serial number of your trolling motor
- Proof of purchase or registration verification
- Nature of problem

## Mercury Marine Service Offices

For assistance, call, fax, or write. Please include your daytime telephone number with mail and fax correspondence.

<b>United States</b>		
Telephone	(920) 929-5040	Mercury Marine W6250 W. Pioneer Road Fond du Lac, WI 54936-1939
Fax	(920) 929-5893	
Website	www.motorguide.com	

<b>Canada</b>		
Telephone	(905) 567-6372	Mercury Marine Ltd. 2395 Meadowpine Blvd. Mississauga, Ontario L5N 7W6 Canada
Fax	(905) 567-8515	

<b>Australia, Pacific</b>		
Telephone	(61) (3) 9791-5822	Mercury Marine Australia 132-140 Frankston Road Dandenong, Victoria 3164 Australia
Fax	(61) (3) 9793-5880	

<b>Europe, Middle East, Africa</b>		
Telephone	(32) (87) 32 • 32 • 11	Marine Power - Europe, Inc. Parc Industriel de Petit-Rechain B-4800 Verviers, Belgium
Fax	(32) (87) 31 • 19 • 65	

<b>Mexico, Central America, South America, Caribbean</b>		
Telephone	(954) 744-3500	Mercury Marine 11650 Interchange Circle North Miramar, FL 33025 U.S.A.
Fax	(954) 744-3535	

<b>Japan</b>		
Telephone	81-053-423-2500	Mercury Marine - Japan Anshin-cho 283-1 Hamamatsu Shizuoka-ken, Japan 435-0005 Japan
Fax	81-053-423-2510	

<b>Asia, Singapore</b>		
Telephone	5466160	Mercury Marine Singapore 72 Loyang Way Singapore, 508762
Fax	5467789	

## Notes:



# Section 10 - Accessories

## Table of Contents







---









Trolling Motor Accessories.....	54
---------------------------------	----

---

## Trolling Motor Accessories

MotorGuide accessories available wherever trolling motors are sold.

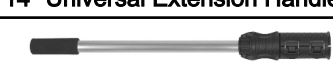
<b>2-Blade Power Prop Kit</b>		
 39081	Hub size: 8.9 cm (3.5 in.) Application: power and efficiency Includes 2-blade propeller, prop nut and large prop pin	MGA0495B
<b>3-Blade Machete III Black</b>		
 39082	Hub size: 8.9 cm (3.5 in.) Application: speed and efficiency Includes 3-blade propeller, prop nut and large prop pin	MGA089B
<b>3-Blade Machete III White Glass-Filled</b>		
 39083	Hub size: 8.9 cm (3.5 in.) Application: speed and efficiency Includes 3-blade propeller, prop nut and large prop pin	MGA089W
<b>3-Blade Aluminum Machete</b>		
 39157	Hub size: 8.9 cm (3.5 in.) Application: shallow and durability Includes 3-blade propeller, prop nut and large prop pin	MGA087M
<b>MotorGuide Prop Wrench Kit</b>		
 37853	Comes complete with spare prop nut and two prop pins, allowing fast prop changes.	MGA050B6
<b>Replacement Handle</b>		
 39084	With soft grip handle and Tour rope for unsurpassed durability.	8M4000275
<b>Mounting Isolators</b>		
 39086	Absorbs shock and protects electronics. Ideal for mounting all marine accessories without having to go under the deck. Four per package.	MGA015PB6

<b>Trolling Motor Mounting Kit</b>		
 39087	Absorbs shock and protects electronics. Steel bolts and washers fit all trolling motors. Four per package.	8M4000873
<b>Trolling Motor Power Plug</b>		
 38003	Two-prong, 12-, 24- or 36-volt power plug provides a solid, safe connection.	8M4000953
<b>Trolling Motor SP (receptacle)</b>		
 38004	Matching two-prong 12-, 24- or 36-volt power plug provides a solid, safe connection.	8M4000954
<b>6 Gauge Battery Cable and Terminals with 50-Amp Manual Reset Breaker</b>		
 38006	Protect your investment with this 50-amp manual reset breaker and heavy-duty 6-gauge battery cable and terminal.	MM309922T
<b>50-Amp Manual Reset Breaker</b>		
 38007	Protect your motor and boat wiring.	MM5870
<b>50-Amp Alligator Clips</b>		
 38005	Feature upscale grip design and higher amp rating.	8M4000287
<b>14" Universal Extension Handle</b>		
 39090	For transom mount and bow mount trolling motors.	MGA504A1
<b>24" Universal Telescoping Extension Handle</b>		
 39089	For transom mount and bow mount trolling motors.	MGA503A1
<b>36" Universal Extension Handle</b>		
 39088	For transom mount and bow mount trolling motors.	8M4000283