

Welcome Aboard!

Proper care and maintenance is an important part in keeping your Mercury Product operating at peak efficiency for maximum performance and economy. The enclosed Owner's Registration Card is your key to trouble-free family fun. Refer to your **Operation and Maintenance Manual** for full details of your warranty coverage.

Details of your nearest dealer can be found on www.marinepower.com where country maps and full contact information are displayed.

Is your engine properly registered for warranty purpose? Please check on www.marinepower.com. If necessary, please contact your local dealer.

Declaration of Conformity - Optimax

Manufacturer:	Mercury Marine W6250 Pioneer Road P.O. Box 1939 Fond du Lac, WI 54935-1939 USA ,
Authorized Representative:	Marine Power Europe, Inc. Parc Industriel de Petit-Rechain B-2800 Verviers - Belgium,

If the CE mark is accompanied by a notified body number, the following Recreational Craft Directive applies:

Recreational Craft Directive: 2003/44/EC amending 94/25/EC

Applicable Requirement	Standards Applied
Owner's manual (A.2.5)	EN ISO 10240:2004
Handling characteristics (A.4)	EN ISO 8665:1995
Outboard engines starting (A.5.1.4)	EN ISO 11547:1995
General steering system (A.5.4.1)	ABYC P-17; EN ISO 10592:1995
Exhaust emission requirements (B.2)	EN ISO 8178-1: 1996
Owner's manual (B.4)	EN ISO 8665:1995
Noise emission levels (C.1)	EN ISO 14509:2000

Module used for exhaust emission assessment: Module H; Certification No. RCD-H-2

Module used for noise emission assessment: Module H; Certification No. RCD-H-2

Name of Notified Body for exhaust emission assessment and noise emission assessment:

Det Norske Veritas AS

Veritasveien 1

1322 Hovik

Norway

Notified Body Number: 0575

Engine type: Outboard **Fuel type:** Gasoline **Combustion cycle:** 2 stroke, direct injection **Brands:** Mercury, Mariner

Engine Family	Manufacture Location	Horsepower	Starting Serial Number	Module H Noise and Exhaust Certificate

Optimax 1.5 L	Fond du Lac, Wisconsin USA	75, 90,115	1B227000	RCD-H-2
Optimax 2.5 L	Fond du Lac, Wisconsin USA	135, 150	1B227000	RCD-H-2
Optimax 3.0 L	Fond du Lac, Wisconsin USA	200	1B227000	RCD-H-2

If the CE mark is not accompanied by the notified body number, the following Recreational Craft Directive language applies only to product entering the EU prior to January 1, 2007:

Recreational Craft Directive:

94/25/EC

Applicable Requirement	Standards Applied
Owner's manual (A.2.5)	ISO 10240
Handling characteristics (A.4)	ISO 8665
Outboard engine starting (A.5.1.4)	ISO 11547
Fuel tanks (A.5.2.2)	ISO 13591; ISO 8469
General steering system (A.5.4.1)	ABYC P-17

The following applies to all products covered by this manual:

Safety of Machinery Directive

98/37/EC

Principles of safety integration (1.1.2)	ISO 12100-1; ISO 12100-2; EN 1050
Noise (1.5.8)	ICOMIA 39/94
Vibration (1.5.9)	ICOMIA 38/94

Electromagnetic Compatibility Directive 89/336/EC

Generic emission standard	EN 61000-6-3
Generic immunity standard	EN 61000-6-1
Vehicles, boats and internal combustion engine driven devices - radio disturbance characteristics	SAE J551 (CISPR 12) CISPR 12; EN 55012:2002/A1:2005
Electrostatic discharge testing	EN 61000-6-2; EN 61000-4-2; EN 61000-4-3

This declaration is issued under the sole responsibility of Mercury Marine and Marine Power Europe.

A handwritten signature in black ink, reading "P. Mackey". The signature is fluid and cursive, with a long horizontal stroke extending to the right from the end of the name.

Patrick C. Mackey

President, Mercury Marine, Fond du Lac, WI USA on May 1, 2006.

European Regulations Contact:

Regulations and Product Safety Department, Mercury Marine,
Fond du Lac, WI USA

TABLE OF CONTENTS

Warranty Information

Transfer Of Warranty.....	1
Warranty Registration United States And Canada.....	1
Warranty Registration Outside The United States And Canada.....	1
Optimax Outboard Limited Warranty United States, Canada, Europe, Confederation of Independent States, Middle-East and Africa.....	2
3 Year Limited Warranty Against Corrosion.....	3
Warranty Coverage And Exclusions.....	5

General Information

Boater's Responsibilities.....	6
Before Operating Your Outboard.....	6
Boat Horsepower Capacity.....	6
High-Speed and High-Performance Boat Operation.....	7
Propeller Selection.....	7
Outboard Remote Control Models.....	9
Remote Steering Notice.....	9
Lanyard Stop Switch.....	9
Protecting People In The Water.....	11
Passenger Safety Message - Pontoon Boats And Deck Boats.....	11
Wave And Wake Jumping.....	12
Impact With Underwater Hazards.....	13
Exhaust Emissions.....	13
Selecting Accessories For Your Outboard.....	15
Safe Boating Suggestions.....	15
Recording Serial Number.....	16
135/150/175 OptiMax Specifications.....	16
Component Identification.....	17

Transporting

Trailing Boat/Outboard.....	18
-----------------------------	----

Fuel and Oil

Fuel Recommendations.....	19
Oil Recommendation.....	19
Fuel Additives.....	20
Fuel Requirements.....	20
Avoiding Fuel Flow Restriction.....	20
Filling Remote Oil Tank.....	20
Filling Engine Mounted Oil Reservoir Tank.....	20
Filling Fuel Tank.....	21

Features and Controls

Remote Control Features.....	22
Warning System.....	22
Power Trim And Tilt.....	24

TABLE OF CONTENTS

Operation

Pre-Starting Check List.....	27
Operating In Freezing Temperatures.....	27
Operating In Salt Water Or Polluted Water.....	27
Operating at High Elevations.....	27
Setting Trim Angle While Running Engine at Idle Speed.....	28
Engine Break-in Procedure.....	28
Starting The Engine.....	28
Gear Shifting.....	31
Stopping The Engine.....	31

Maintenance

Outboard Care.....	32
EPA Emissions.....	32
Inspection And Maintenance Schedule.....	32
Flushing The Cooling System.....	33
Top Cowl Removal And Installation.....	34
Cleaning Care for Top Cowl.....	34
Flywheel Cover Removal and Installation.....	35
Fuel System.....	35
Steering Link Rod Fasteners.....	36
Fuse Replacement.....	37
Corrosion Control Anode.....	38
Battery Inspection.....	38
Battery Information.....	39
Propeller Replacement.....	40
Spark Plug Inspection And Replacement.....	42
Compressor Air Intake Filter.....	43
Alternator Belt Inspection.....	44
Lubrication Points.....	44
Gearcase Lubrication.....	47
Submerged Outboard.....	48

Storage

Storage Preparation.....	49
Protecting Internal Engine Components.....	49
Protecting External Outboard Components.....	50
Gearcase.....	50
Positioning Outboard For Storage.....	50
Battery Storage.....	50

Troubleshooting

Starter Motor Will Not Crank the Engine.....	51
Engine Will Not Start.....	51
Engine Runs Erratically.....	51
Performance Loss.....	52
Battery Will Not Hold Charge.....	52

TABLE OF CONTENTS

OWNER SERVICE ASSISTANCE

Local Repair Service.....	53
Service Away From Home.....	53
Parts And Accessories Inquiries.....	53
Service Assistance.....	53
Mercury Marine Service Offices.....	53

OUTBOARD INSTALLATION

Important Information.....	55
Avoiding Fuel Flow Restriction.....	55
Electric Fuel Pump.....	55
Boat Horsepower Capacity.....	55
Start in Gear Protection.....	56
Selecting Accessories For Your Outboard.....	56
Fuel Tanks.....	56
Installation Specifications.....	57
Lifting the Outboard.....	57
Steering Cable - Starboard Side Routed Cable.....	58
Steering Link Rod Fasteners.....	59
Determining Recommended Outboard Mounting Height.....	61
Drilling Outboard Mounting Holes.....	61
Fastening the Outboard to the Transom.....	63
Electrical, Hoses, and Control Cables.....	65
Shift and Throttle Cable.....	69
Front Clamp Reassembly.....	73
Filling the Fuel System.....	74
Oil Injection Set-up.....	75
Propeller Installation.....	77
Trim In Pin.....	78

WARRANTY INFORMATION

Transfer Of Warranty

The limited warranty is transferable to a subsequent purchaser, but only for the remainder of the unused portion of the limited warranty. This will not apply to products used for commercial applications.

To transfer the warranty to the subsequent owner, send or fax a copy of the bill of sale or purchase agreement, new owner's name, address and engine serial number to Mercury Marine's warranty registration department. In the United States and Canada, mail to:

Mercury Marine
Attn: Warranty Registration Department
W6250 W. Pioneer Road
P.O. Box 1939
Fond du Lac, WI 54936-1939
920-929-5054
Fax 920-929-5893

Upon processing the transfer of warranty, Mercury Marine will send registration verification to the new owner of the product by mail.

There is no charge for this service.

For products purchased outside the United States and Canada, contact the distributor in your country, or the Marine Power Service Center closest to you.

Warranty Registration United States And Canada

Outside United States and Canada - Check with your local distributor.

1. You may change your address at any time, including at time of warranty claim, by calling Mercury Marine or sending a letter or fax with your name, old address, new address, and engine serial number to Mercury Marine's warranty registration department. Your dealer can also process this change of information.

Mercury Marine
Attn: Warranty Registration Department
W6250 W. Pioneer Road
P.O. Box 1939
Fond du Lac, WI 54936-1939
920-929-5054
Fax 920-929-5893

NOTE: *Registration lists must be maintained by Mercury Marine and any dealer on marine products sold in the United States, should a safety recall notification under the Federal Safety Act be required.*

2. To be eligible for warranty coverage, the product must be registered with Mercury Marine. At the time of sale, the dealer should complete the warranty registration and immediately submit it to Mercury Marine via MercNET, E-mail, or mail. Upon receipt of this warranty registration, Mercury Marine will record the registration.
3. Upon processing the warranty registration, Mercury Marine will send registration verification by mail to the purchaser of the product. If this registration verification is not received within 30 days, please contact your selling dealer immediately. Warranty coverage is not effective until your product is registered with Mercury Marine.

Warranty Registration Outside The United States And Canada

1. It is important that your selling dealer fills out the Warranty Registration Card completely and mails it to the distributor or Marine Power Service Center responsible for administering the warranty registration/claim program for your area.
2. The Warranty Registration Card identifies your name and address, product model and serial numbers, date of sale, type of use and the selling distributor's/dealer's code number, name and address. The distributor/dealer also certifies that you are the original purchaser and user of the product.

WARRANTY INFORMATION

3. A copy of the Warranty Registration Card, designated as the Purchaser's Copy, MUST be given to you immediately after the card has been completely filled out by the selling distributor/dealer. This card represents your factory registration identification, and should be retained by you for future use when required. Should you ever require warranty service on this product, your dealer may ask you for the Warranty Registration Card to verify date of purchase and to use the information on the card to prepare the warranty claim forms.
4. In some countries, the Marine Power Service Center will issue you a permanent (plastic) Warranty Registration Card within 30 days after receiving the Factory Copy of the Warranty Registration Card from your distributor/dealer. If you receive a plastic Warranty Registration Card, you may discard the Purchaser's Copy that you received from the distributor/dealer when you purchased the product. Ask your distributor/dealer if this plastic card program applies to you.

IMPORTANT: Registration lists must be maintained by the factory and dealer in some countries by law. It is our desire to have ALL products registered at the factory should it ever be necessary to contact you. Make sure your dealer/distributor fills out the warranty registration card immediately and sends the factory copy to the Marine Power International Service Center for your area.

5. For further information concerning the Warranty Registration Card and its relationship to Warranty Claim processing, refer to the International Warranty.

Optimax Outboard Limited Warranty United States, Canada, Europe, Confederation of Independent States, Middle-East and Africa

Outside the United States, Canada, Europe, Confederation of Independent States, Middle-East and Africa - check with your local distributor.

WHAT IS COVERED: Mercury Marine warrants its new Outboard and Jet Products to be free of defects in material and workmanship during the period described below.

DURATION OF COVERAGE: This Limited Warranty provides coverage for three (3) years from the date the product is first sold to a recreational use retail purchaser, or the date on which the product is first put into service, whichever occurs first. Commercial users of these products receive warranty coverage of one (1) year from the date of first retail sale, or one (1) year from the date in which the product was first put into service, whichever occurs first. Commercial use is defined as any work or employment related use of the product, or any use of the product which generates income, for any part of the warranty period, even if the product is only occasionally used for such purposes. The repair or replacement of parts, or the performance of service under this warranty, does not extend the life of this warranty beyond its original expiration date. Unexpired warranty coverage can be transferred from one recreational use customer to a subsequent recreational use customer upon proper re-registration of the product. Unexpired warranty coverage cannot be transferred either to or from a commercial use customer.

CONDITIONS THAT MUST BE MET IN ORDER TO OBTAIN WARRANTY COVERAGE: Warranty coverage is available only to retail customers that purchase from a Dealer authorized by Mercury Marine to distribute the product in the country in which the sale occurred, and then only after the Mercury Marine specified pre-delivery inspection process is completed and documented. Warranty coverage becomes available upon proper registration of the product by the authorized dealer. Routine maintenance outlined in the Operation and Maintenance Manual must be timely performed in order to maintain warranty coverage. Mercury Marine reserves the right to make future warranty coverage contingent on proof of proper maintenance.

WHAT MERCURY WILL DO: Mercury's sole and exclusive obligation under this warranty is limited to, at our option, repairing a defective part, replacing such part or parts with new or Mercury Marine certified remanufactured parts, or refunding the purchase price of the Mercury product. Mercury reserves the right to improve or modify products from time to time without assuming an obligation to modify products previously manufactured.

WARRANTY INFORMATION

HOW TO OBTAIN WARRANTY COVERAGE: The customer must provide Mercury with a reasonable opportunity to repair, and reasonable access to the product for warranty service. Warranty claims shall be made by delivering the product for inspection to a Mercury dealer authorized to service the product. If purchaser cannot deliver the product to such a dealer, written notice must be given to Mercury. We will then arrange for the inspection and any covered repair. Purchaser in that case shall pay for all related transportation charges and/or travel time. If the service provided is not covered by this warranty, purchaser shall pay for all related labor and material, and any other expenses associated with that service. Purchaser shall not, unless requested by Mercury, ship the product or parts of the product directly to Mercury. Proof of registered ownership must be presented to the dealer at the time warranty service is requested in order to obtain coverage.

WHAT IS NOT COVERED: This limited warranty does not cover routine maintenance items, tune ups, adjustments, normal wear and tear, damage caused by abuse, abnormal use, use of a propeller or gear ratio that does not allow the engine to run in its recommended wide open throttle RPM range (see the Operation and Maintenance Manual), operation of the product in a manner inconsistent with the recommended operation/duty cycle section of the Operation and Maintenance Manual, neglect, accident, submersion, improper installation (proper installation specifications and techniques are set forth in the installation instructions for the product), improper service, use of an accessory or part not manufactured or sold by us, jet pump impellers and liners, operation with fuels, oils or lubricants which are not suitable for use with the product (see the Operation and Maintenance Manual), alteration or removal of parts, or water entering the engine through the fuel intake, air intake or exhaust system, or damage to the product from insufficient cooling water caused by blockage of the cooling system by a foreign body, running the engine out of water, mounting the engine too high on the transom, or running the boat with the engine trimmed out too far.. Use of the product for racing or other competitive activity, or operating with a racing type lower unit, at any point, even by a prior owner of the product, voids the warranty.

Expenses related to haul out, launch, towing, storage, telephone, rental, inconvenience, slip fees, insurance coverage, loan payments, loss of time, loss of income, or any other type of incidental or consequential damages are not covered by this warranty. Also, expenses associated with the removal and/or replacement of boat partitions or material caused by boat design for access to the product are not covered by this warranty.

No individual or entity, including Mercury Marine authorized dealers, has been given authority by Mercury Marine to make any affirmation, representation or warranty regarding the product, other than those contained in this limited warranty, and if made, shall not be enforceable against Mercury Marine.

For additional information regarding events and circumstances covered by this warranty, and those that are not, see the Warranty Coverage section of the Operation and Maintenance Manual, incorporated by reference into this warranty.

DISCLAIMERS AND LIMITATIONS:

THE IMPLIED WARRANTIES OF MERCHANTABILITY AND FITNESS FOR A PARTICULAR PURPOSE ARE EXPRESSLY DISCLAIMED. TO THE EXTENT THAT THEY CANNOT BE DISCLAIMED, THE IMPLIED WARRANTIES ARE LIMITED IN DURATION TO THE LIFE OF THE EXPRESS WARRANTY. INCIDENTAL AND CONSEQUENTIAL DAMAGES ARE EXCLUDED FROM COVERAGE UNDER THIS WARRANTY. SOME STATES/COUNTRIES DO NOT ALLOW FOR THE DISCLAIMERS, LIMITATIONS AND EXCLUSIONS IDENTIFIED ABOVE, AS A RESULT, THEY MAY NOT APPLY TO YOU. THIS WARRANTY GIVES YOU SPECIFIC LEGAL RIGHTS, AND YOU MAY ALSO HAVE OTHER LEGAL RIGHTS WHICH VARY FROM STATE TO STATE AND COUNTRY TO COUNTRY.

3 Year Limited Warranty Against Corrosion

WHAT IS COVERED: Mercury Marine warrants that each new Mercury, Mariner, Mercury Racing, Sport Jet, M² Jet Drive, Tracker by Mercury Marine Outboard, Mercury MerCruiser Inboard or Sterndrive Engine (Product) will not be rendered inoperative as a direct result of corrosion for the period of time described below.

DURATION OF COVERAGE: This limited corrosion warranty provides coverage for three (3) years from either the date the product is first sold, or the date on which the product is first put into service, whichever occurs first. The repair or replacement of parts, or the performance of service under this warranty does not extend the life of this warranty beyond its original expiration date. Unexpired warranty coverage can be transferred to subsequent (non-commercial use) purchaser upon proper re-registration of the product.

WARRANTY INFORMATION

CONDITIONS THAT MUST BE MET IN ORDER TO OBTAIN WARRANTY COVERAGE: Warranty coverage is available only to retail customers that purchase from a Dealer authorized by Mercury Marine to distribute the product in the country in which the sale occurred, and then only after the Mercury Marine specified pre-delivery inspection process is completed and documented. Warranty coverage becomes available upon proper registration of the product by the authorized dealer. Corrosion prevention devices specified in the Operation and Maintenance Manual must be in use on the boat, and routine maintenance outlined in the Operation and Maintenance Manual must be timely performed (including without limitation the replacement of sacrificial anodes, use of specified lubricants, and touch-up of nicks and scratches) in order to maintain warranty coverage. Mercury Marine reserves the right to make warranty coverage contingent upon proof of proper maintenance.

WHAT MERCURY WILL DO: Mercury's sole and exclusive obligation under this warranty is limited to, at our option, repairing a corroded part, replacing such part or parts with new or Mercury Marine certified re-manufactured parts, or refunding the purchase price of the Mercury product. Mercury reserves the right to improve or modify products from time to time without assuming an obligation to modify products previously manufactured.

HOW TO OBTAIN WARRANTY COVERAGE: The customer must provide Mercury with a reasonable opportunity to repair, and reasonable access to the product for warranty service. Warranty claims shall be made by delivering the product for inspection to a Mercury dealer authorized to service the product. If purchaser cannot deliver the product to such a dealer, written notice must be given to Mercury. We will then arrange for the inspection and any covered repair. Purchaser in that case shall pay for all related transportation charges and/or travel time. If the service provided is not covered by this warranty, purchaser shall pay for all related labor and material, and any other expenses associated with that service. Purchaser shall not, unless requested by Mercury, ship the product or parts of the product directly to Mercury. Proof of registered ownership must be presented to the dealer at the time warranty service is requested in order to obtain coverage.

WHAT IS NOT COVERED: This limited warranty does not cover electrical system corrosion; corrosion resulting from damage, corrosion which causes purely cosmetic damage, abuse or improper service; corrosion to accessories, instruments, steering systems; corrosion to factory installed jet drive unit; damage due to marine growth; product sold with less than a one year limited Product warranty; replacement parts (parts purchased by customer); products used in a commercial application. Commercial use is defined as any work or employment related use of the product, or any use of the product which generates income, for any part of the warranty period, even if the product is only occasionally used for such purposes.

Corrosion damage caused by stray electrical currents (on-shore power connections, nearby boats, submerged metal) is not covered by this corrosion warranty and should be protected against by the use of a corrosion protection system, such as the Mercury Precision Parts or Quicksilver MerCathode system and/or Galvanic Isolator. Corrosion damage caused by improper application of copper base anti-fouling paints is also not covered by this limited warranty. If anti-fouling protection is required, Tri-Butyl-Tin-Adipate (TBTA) base anti-fouling paints are recommended on Outboard and MerCruiser boating applications. In areas where TBTA base paints are prohibited by law, copper base paints can be used on the hull and transom. Do not apply paint to the outboard or MerCruiser product. In addition, care must be taken to avoid an electrical interconnection between the warranted product and the paint. For MerCruiser product, an unpainted gap of at least 38 mm (1.5 in.) should be left around the transom assembly. Refer to the Operation and Maintenance Manual for additional details.

For additional information regarding events and circumstances covered by this warranty, and those that are not, see the Warranty Coverage section of the Operation and Maintenance Manual, incorporated by reference into this warranty.

DISCLAIMERS AND LIMITATIONS:

THE IMPLIED WARRANTIES OF MERCHANTABILITY AND FITNESS FOR A PARTICULAR PURPOSE ARE EXPRESSLY DISCLAIMED. TO THE EXTENT THAT THEY CANNOT BE DISCLAIMED, THE IMPLIED WARRANTIES ARE LIMITED IN DURATION TO THE LIFE OF THE EXPRESS WARRANTY. INCIDENTAL AND CONSEQUENTIAL DAMAGES ARE EXCLUDED FROM COVERAGE UNDER THIS WARRANTY. SOME STATES/COUNTRIES DO NOT ALLOW FOR THE DISCLAIMERS, LIMITATIONS AND EXCLUSIONS IDENTIFIED ABOVE, AS A RESULT, THEY MAY NOT APPLY TO YOU. THIS WARRANTY GIVES YOU SPECIFIC LEGAL RIGHTS, AND YOU MAY ALSO HAVE OTHER LEGAL RIGHTS WHICH VARY FROM STATE TO STATE AND COUNTRY TO COUNTRY.

WARRANTY INFORMATION

Warranty Coverage And Exclusions

The purpose of this section is to help eliminate some of the more common misunderstandings regarding warranty coverage. The following information explains some of the types of services that are not covered by warranty. The provisions set forth following have been incorporated by reference into the Three Year Limited Warranty Against Corrosion Failure, the International Limited Outboard Warranty, and the United States and Canada Limited Outboard Warranty.

Keep in mind that warranty covers repairs that are needed within the warranty period because of defects in material and workmanship. Installation errors, accidents, normal wear, and a variety of other causes that affect the product are not covered.

Warranty is limited to defects in material or workmanship, but only when the consumer sale is made in the country to which distribution is authorized by us.

Should you have any questions concerning warranty coverage, contact your authorized dealer. They will be pleased to answer any questions that you may have.

GENERAL EXCLUSIONS FROM WARRANTY

1. Minor adjustments and tune-ups, including checking, cleaning or adjusting spark plugs, ignition components, carburetor settings, filters, belts, controls, and checking lubrication made in connection with normal services.
2. Factory installed jet drive units - Specific parts excluded from the warranty are: The jet drive impeller and jet drive liner damaged by impact or wear, and water damaged drive shaft bearings as a result of improper maintenance.
3. Damage caused by neglect, lack of maintenance, accident, abnormal operation or improper installation or service.
4. Haul out, launch, towing charges, removal and/or replacement of boat partitions or material because of boat design for necessary access to the product, all related transportation charges and/or travel time, etc. Reasonable access must be provided to the product for warranty service. Customer must deliver product to an authorized dealer.
5. Additional service work requested by customer other than that necessary to satisfy the warranty obligation.
6. Labor performed by other than an authorized dealer may be covered only under following circumstances: When performed on emergency basis (providing there are no authorized dealers in the area who can perform the work required or have no facilities to haul out, etc., and prior factory approval has been given to have the work performed at this facility).
7. All incidental and/or consequential damages (storage charges, telephone or rental charges of any type, inconvenience or loss of time or income) are the owner's responsibility.
8. Use of other than Mercury Precision or Quicksilver parts when making warranty repairs.
9. Oils, lubricants or fluids changed as a matter of normal maintenance is customer's responsibility unless loss or contamination of same is caused by product failure that would be eligible for warranty consideration.
10. Participating in or preparing for racing or other competitive activity or operating with a racing type lower unit.
11. Engine noise does not necessarily indicate a serious engine problem. If diagnosis indicates a serious internal engine condition which could result in a failure, condition responsible for noise should be corrected under the warranty.
12. Lower unit and/or propeller damage caused by striking a submerged object is considered a marine hazard.
13. Water entering engine through the fuel intake, air intake or exhaust system or submersion.
14. Failure of any parts caused by lack of cooling water, which results from starting motor out of water, foreign material blocking inlet holes, motor being mounted too high or trimmed too far out.
15. Use of fuels and lubricants which are not suitable for use with or on the product. Refer to the **Maintenance** section.
16. Our limited warranty does not apply to any damage to our products caused by the installation or use of parts and accessories which are not manufactured or sold by us. Failures which are not related to the use of those parts or accessories are covered under warranty if they otherwise meet the terms of the limited warranty for that product.

GENERAL INFORMATION

Boater's Responsibilities

The operator (driver) is responsible for the correct and safe operation of the boat and safety of its occupants and general public. It is strongly recommended that each operator (driver) read and understand this entire manual before operating the outboard.

Be sure at least one additional person on board is instructed in the basics of starting and operating the outboard and boat handling in case the driver is unable to operate the boat.

Before Operating Your Outboard

Read this manual carefully. Learn how to operate your outboard properly. If you have any questions, contact your dealer.

Safety and operating information that is practiced, along with using good common sense, can help prevent personal injury and product damage.

This manual as well as safety labels posted on the outboard use the following safety alerts to draw your attention to special safety instructions that should be followed.

DANGER

Indicates a hazardous situation which, if not avoided, will result in death or serious injury.

WARNING

Indicates a hazardous situation which, if not avoided, could result in death or serious injury.

CAUTION

Indicates a hazardous situation which, if not avoided, could result in minor or moderate injury.

NOTICE

Indicates a situation which, if not avoided, could result in engine or major component failure.

Boat Horsepower Capacity

WARNING

Exceeding the boat's maximum horsepower rating can cause serious injury or death. Overpowering the boat can affect boat control and flotation characteristics or break the transom. Do not install an engine that exceeds the boat's maximum power rating.

GENERAL INFORMATION

Do not overpower or overload your boat. Most boats will carry a required capacity plate indicating the maximum acceptable power and load as determined by the manufacturer following certain federal guidelines. If in doubt, contact your dealer or the boat manufacturer.

U.S. COAST GUARD CAPACITY	
MAXIMUM HORSEPOWER	XXX
MAXIMUM PERSON CAPACITY (POUNDS)	XXX
MAXIMUM WEIGHT CAPACITY	XXX

26777

High-Speed and High-Performance Boat Operation

If your outboard is to be used on a high speed or high performance boat with which you are unfamiliar, we recommend that you never operate it at its high speed capability without first requesting an initial orientation and familiarization demonstration ride with your dealer or an operator experienced with your boat/outboard combination. For additional information, obtain a copy of our **Hi-Performance Boat Operation** booklet from your dealer, distributor, or Mercury Marine.

Propeller Selection

The propeller on your outboard is one of the most important components in the propulsion system. An improper propeller choice can significantly affect the performance of your boat and could result in damage to the outboard engine.

When choosing a propeller, a full selection of aluminum and stainless steel propellers specifically designed for your outboard are available through Mercury Marine. To view the entire product offering and find the correct propeller that is best suited for your application, visit www.mercmarinepropellers.com or see your local authorized Mercury dealer.

SELECTING THE CORRECT PROPELLER

An accurate tachometer for measuring engine speed is important in choosing the correct propeller.

Choose a propeller for your boating application that will allow the engine to operate within the specified full throttle operating range. When operating the boat at full throttle under normal load conditions, the engine RPM should be in the upper half of the recommended full throttle RPM range. Refer to **Specifications**. If engine RPM is above that range, select a propeller of increased pitch in order to reduce engine RPM. If engine RPM is below the recommended range, select a propeller of reduced pitch to increase engine RPM.

IMPORTANT: To ensure proper fit, and performance, Mercury Marine recommends the use of Mercury or Quicksilver branded propellers and mounting hardware.

GENERAL INFORMATION

Propellers are designated by the diameter, pitch, number of blades, and material. The diameter and pitch are stamped (cast) into the side or the end of the propeller hub. The first number represents the diameter of the propeller and the second number represents the pitch. For example, 14x19 represents a propeller with a 14 inch diameter and 19 inches of pitch.

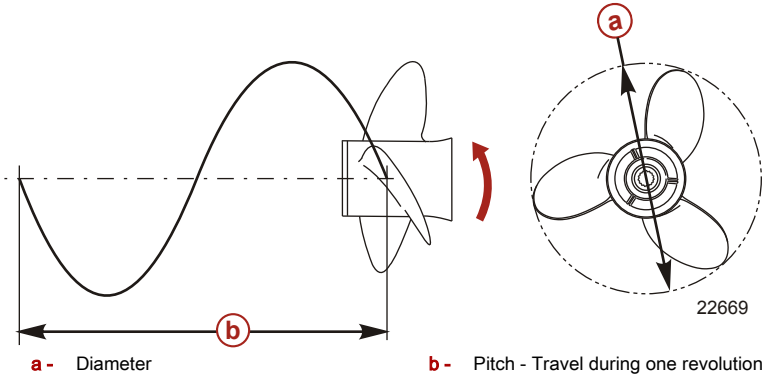

The following are some propeller basics that will help you determine the correct propeller for your boating application.

Diameter - The diameter is the distance across the imaginary circle that is made when the propeller rotates. The correct diameter for each propeller has been predetermined for the design of your outboard. However, when more than one diameter is available for the same pitch, use a larger diameter for heavy boat applications and a smaller diameter for lighter applications.

Pitch - The pitch is the theoretical distance, in inches, that a propeller travels forward during one revolution. Pitch can be thought of similar to gears in a car. The lower the gear, the faster the car will accelerate, but with lower overall top speed. Likewise, a lower pitch propeller will accelerate quickly, but top-end speed will be reduced. The higher the propeller pitch the faster the boat will usually go; though typically slowing acceleration.

Determining the Correct Pitch size - First, check the full throttle RPM under normal load condition. If the full throttle RPM is within the recommended range, select a replacement or upgrade propeller with the same pitch as the current propeller.

- Adding 1 inch of pitch will reduce the full throttle RPM by 150 to 200
- Subtracting 1 inch of pitch will increase full throttle RPM by 150 to 200
- Upgrading from a 3-blade propeller to a 4-blade propeller will generally decrease full throttle RPM by 50 to 100

IMPORTANT: Avoid damage to the engine. Never use a propeller which allows the engine to exceed the recommended full throttle RPM range when under normal full throttle operation.

PROPELLER MATERIAL

Most propellers manufactured by Mercury Marine are made from either aluminum or stainless steel. Aluminum is suitable for general purpose use and is standard equipment on many new boats. Stainless steel is over five times more durable than aluminum and typically provides performance gains in acceleration and top end speed due to design efficiencies. Stainless steel propellers also come in a larger variety of sizes and styles that allow you to dial in the ultimate performance for your boat.

3 BLADE VS. 4 BLADE

Available in many sizes of both aluminum and stainless, 3 and 4-blade propellers have unique performance characteristics. In general, 3-blade propellers offer good all around performance and higher top speed than 4-blade propellers. However, 4-blade propellers are usually faster to plane and more efficient at cruising speeds, but lack the top end speed of a 3-blade propeller.

GENERAL INFORMATION

Outboard Remote Control Models

The remote control connected to your outboard must be equipped with a start in neutral only protection device. This prevents the engine from starting when the shift is actuated in any position other than neutral.

WARNING

Starting the engine with the drive in gear can cause serious injury or death. Never operate a boat that does not have a neutral-safety-protection device.

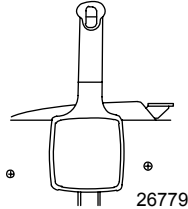

Remote Steering Notice

The steering link rod that connects the steering cable to the engine must be fastened utilizing self-locking nuts. These self-locking nuts must never be replaced with common nuts (non-locking) as they will work loose and vibrate off, freeing the link rod to disengage.

WARNING

Improper fasteners or improper installation procedures can result in loosening or disengagement of the steering link rod. This can cause a sudden, unexpected loss of boat control, resulting serious injury or death due to occupants being thrown within or out of the boat. Always use required components and follow instructions and torque procedures.

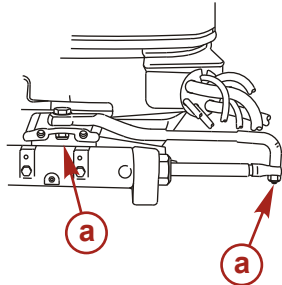

a - Self-locking nuts

Lanyard Stop Switch

The purpose of a lanyard stop switch is to turn off the engine when the operator moves far enough away from the operator's position (as in accidental ejection from the operator's position) to activate the switch. Tiller handle outboards and some remote control units are equipped with a lanyard stop switch. A lanyard stop switch can be installed as an accessory - generally on the dashboard or side adjacent to the operator's position.

GENERAL INFORMATION

The lanyard is a cord usually 122 - 152 cm (4 - 5 feet) in length when stretched out, with an element on one end made to be inserted into the switch and a snap on the other end for attaching to the operator. The lanyard is coiled to make its at-rest condition as short as possible to minimize the likelihood of lanyard entanglement with nearby objects. Its stretched-out length is made to minimize the likelihood of accidental activation should the operator choose to move around in an area close to the normal operator's position. If it is desired to have a shorter lanyard, wrap the lanyard around the operator's wrist or leg, or tie a knot in the lanyard.

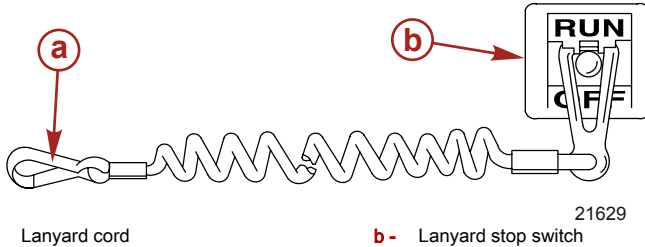

Read the following Safety Information before proceeding.

Important Safety Information: The purpose of a lanyard stop switch is to stop the engine when the operator moves far enough away from the operator's position to activate the switch. This would occur if the operator accidentally falls overboard or moves within the boat a sufficient distance from the operator's position. Falling overboard and accidental ejections are more likely to occur in certain types of boats such as low sided inflatables, bass boats, high performance boats, and light, sensitive handling fishing boats operated by a hand tiller. Falling overboard and accidental ejections are also likely to occur as a result of poor operating practices such as sitting on the back of the seat or gunwale at planing speeds, standing at planing speeds, sitting on elevated fishing boat decks, operating at planing speeds in shallow or obstacle infested waters, releasing your grip on a steering wheel or tiller handle that is pulling in one direction, drinking alcohol or consuming drugs, or daring high speed boat maneuvers.

While activation of the lanyard stop switch will stop the engine immediately, a boat will continue to coast for some distance depending upon the velocity and degree of any turn at shut down. However, the boat will not complete a full circle. While the boat is coasting, it can cause injury to anyone in the boat's path as seriously as the boat would when under power.

We strongly recommend that other occupants be instructed on proper starting and operating procedures should they be required to operate the engine in an emergency (e.g. if the operator is accidentally ejected).

WARNING

If the operator falls out of the boat, stop the engine immediately to reduce the possibility of serious injury or death from being struck by the boat. Always properly connect the operator to the stop switch using a lanyard.

WARNING

Avoid serious injury or death from deceleration forces resulting from accidental or unintended stop switch activation. The boat operator should never leave the operator's station without first disconnecting the stop switch lanyard from the operator.

Accidental or unintended activation of the switch during normal operation is also a possibility. This could cause any, or all, of the following potentially hazardous situations:

- Occupants could be thrown forward due to unexpected loss of forward motion - a particular concern for passengers in the front of the boat who could be ejected over the bow and possibly struck by the gearcase or propeller.
- Loss of power and directional control in heavy seas, strong current or high winds.
- Loss of control when docking.

GENERAL INFORMATION

Protecting People In The Water

WHILE YOU ARE CRUISING

It is very difficult for a person standing or floating in the water to take quick action to avoid a boat heading in his/her direction, even at slow speed.



21604

Always slow down and exercise extreme caution any time you are boating in an area where there might be people in the water.

Whenever a boat is moving (coasting) and the outboard gear shift is in neutral position, there is sufficient force by the water on the propeller to cause the propeller to rotate. This neutral propeller rotation can cause serious injury.

WHILE BOAT IS STATIONARY

WARNING

A spinning propeller, a moving boat, or any solid device attached to the boat can cause serious injury or death to swimmers. Stop the engine immediately whenever anyone in the water is near your boat.

Shift outboard into neutral and shut off the engine before allowing people to swim or be in the water near your boat.

Passenger Safety Message - Pontoon Boats And Deck Boats

Whenever the boat is in motion, observe the location of all passengers. Do not allow any passengers to stand or use seats other than those designated for traveling faster than idle speed. A sudden reduction in boat speed, such as plunging into a large wave or wake, a sudden throttle reduction, or a sharp change of boat direction, could throw them over the front of the boat. Falling over the front of the boat between the two pontoons will position them to be run over by the outboard.

BOATS HAVING AN OPEN FRONT DECK

No one should ever be on the deck in front of the fence while the boat is in motion. Keep all passengers behind the front fence or enclosure.

Persons on the front deck could easily be thrown overboard or persons dangling their feet over the front edge could get their legs caught by a wave and pulled into the water.

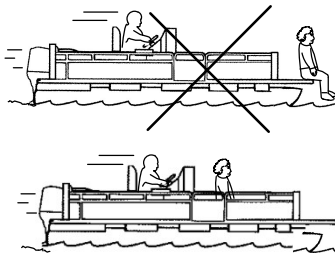

26782

GENERAL INFORMATION

WARNING

Sitting or standing in an area of the boat not designed for passengers at speeds above idle can cause serious injury or death. Stay back from the front end of deck boats or raised platforms and remain seated while the boat is in motion.

BOATS WITH FRONT MOUNTED, RAISED PEDESTAL FISHING SEATS

Elevated fishing seats are not intended for use when the boat is traveling faster than idle or trolling speed. Sit only in seats designated for traveling at faster speeds.

Any unexpected, sudden reduction in boat speed could result in the elevated passenger falling over the front of the boat.

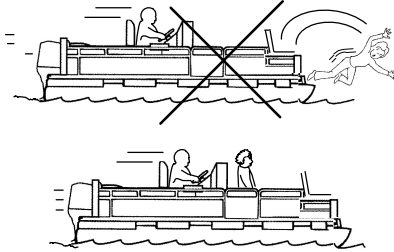

26783

Wave And Wake Jumping

Operating recreational boats over waves and wake is a natural part of boating. However, when this activity is done with sufficient speed to force the boat hull partially or completely out of the water, certain hazards arise, particularly when the boat re-enters the water.

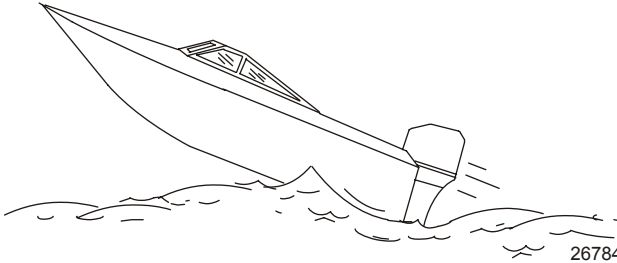

26784

The primary concern is the boat changing direction while in the midst of the jump. In such case the landing may cause the boat to veer violently in a new direction. Such a sharp change in direction can cause occupants to be thrown out of their seats, or out of the boat.

WARNING

Wave or wake jumping can cause serious injury or death from occupants being thrown within or out of the boat. Avoid wave or wake jumping whenever possible.

There is another less common hazardous result from allowing your boat to launch off a wave or wake. If the bow of your boat pitches down far enough while airborne, upon water contact it may penetrate under the water surface and submarine for an instant. This will bring the boat to a nearly instantaneous stop and can send the occupants flying forward. The boat may also steer sharply to one side.

GENERAL INFORMATION

Impact With Underwater Hazards

Reduce speed and proceed with caution whenever you drive a boat in shallow water areas, or in areas where you suspect underwater obstacles may exist which could be struck by the outboard or the boat bottom. **The most important thing you can do to help reduce injury or impact damage from striking a floating or underwater object is to control the boat speed. Under these conditions, boat speed should be kept to a minimum planing speed of 24 to 40 km/h (15 to 25 MPH).**

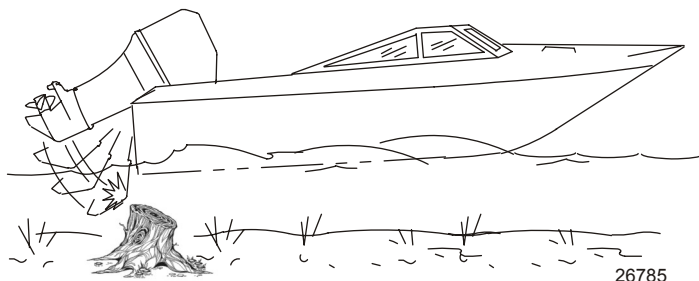

Striking a floating or underwater object could result in an infinite number of situations. Some of these situations could result in the following:

- Part of the outboard or the entire outboard could break loose and fly into the boat.
- The boat could move suddenly in a new direction. Such a sharp change in direction can cause occupants to be thrown out of their seats or out of the boat.
- A rapid reduction in speed. This will cause occupants to be thrown forward, or even out of the boat.
- Impact damage to the outboard and/or boat.

Keep in mind, the most important thing you can do to help reduce injury or impact damage during an impact is control the boat speed. Boat speed should be kept to a minimum planing speed when driving in waters known to have underwater obstacles.

After striking a submerged object, stop the engine as soon as possible and inspect it for any broken or loose parts. If damage is present or suspected, the outboard should be taken to an authorized dealer for a thorough inspection and necessary repair.

The boat should also be checked for any hull fractures, transom fractures, or water leaks.

Operating a damaged outboard could cause additional damage to other parts of the outboard, or could affect control of the boat. If continued running is necessary, do so at greatly reduced speeds.

WARNING

Operating a boat or engine with impact damage can result in product damage, serious injury, or death. If the vessel experiences any form of impact, have an authorized Mercury Marine dealer inspect and repair the vessel or power package.

Exhaust Emissions

BE ALERT TO CARBON MONOXIDE POISONING

Carbon monoxide is present in the exhaust fumes of all internal combustion engines. This includes the outboards, sterndrives and inboard engines that propel boats, as well as the generators that power various boat accessories. Carbon monoxide is a deadly gas that is odorless, colorless and tasteless.

Early symptoms of carbon monoxide poisoning which should not be confused with seasickness or intoxication, include headache, dizziness, drowsiness, and nausea.

GENERAL INFORMATION

⚠ WARNING

Carbon monoxide poisoning can lead to unconsciousness, brain damage, or death. Keep the boat well ventilated while at rest or underway and avoid prolonged exposure to carbon monoxide.

GOOD VENTILATION

Ventilate passenger area, open side curtains, or forward hatches to remove fumes.

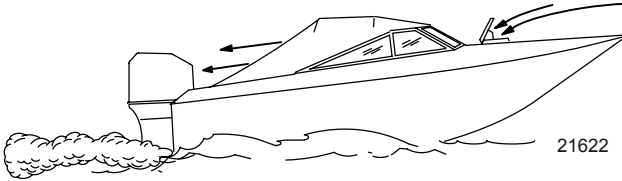

Example of desired air flow through the boat

POOR VENTILATION

Under certain running and/or wind conditions, permanently enclosed or canvas enclosed cabins or cockpits with insufficient ventilation may draw in carbon monoxide. Install one or more carbon monoxide detectors in your boat.

Although the occurrence is rare, on a very calm day, swimmers and passengers in an enclosed area of a stationary boat that contains or is near a running engine may be exposed to a hazardous level of carbon monoxide.

WHILE BOAT IS STATIONARY



a - Running the engine when the boat is moored in a confined space

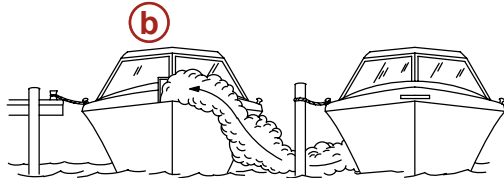

b - Mooring close to another boat that has its engine running

21626

WHILE BOAT IS MOVING



a - Running the boat with the trim angle of the bow too high

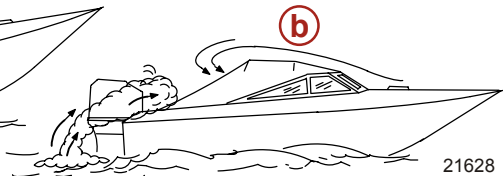

b - Running the boat with no forward hatches open

21628

GENERAL INFORMATION

Selecting Accessories For Your Outboard

Genuine Mercury Precision or Quicksilver Accessories have been specifically designed and tested for your outboard. These accessories are available from Mercury Marine dealers.

IMPORTANT: Check with your dealer before installing accessories. The misuse of approved accessories or the use of non-approved accessories can damage the product.

Some accessories not manufactured or sold by Mercury Marine are not designed to be safely used with your outboard or outboard operating system. Acquire and read the installation, operation, and maintenance manuals for all your selected accessories.

Safe Boating Suggestions

In order to safely enjoy the waterways, familiarize yourself with local and other governmental boating regulations and restrictions, and consider the following suggestions.

Use flotation devices. Have an approved personal flotation device of suitable size for each person aboard (it is the law) and have it readily accessible.

Do not overload your boat. Most boats are rated and certified for maximum load (weight) capacities (refer to your boat capacity plate). If in doubt, contact your dealer or the boats manufacturer.

Perform safety checks and required maintenance. Follow a regular schedule and ensure that all repairs are properly made.

Know and obey all nautical rules and laws of the waterways. Boat operators should complete a boating safety course. Courses are offered in the U.S.A. by 1) The U.S. Coast Guard Auxiliary, 2) The Power Squadron, 3) The Red Cross and 4) your state boating law enforcement agency. Inquiries may be made to the Boating Hotline, 1-800-368-5647 or the Boat U.S. Foundation information number 1-800-336-BOAT.

Make sure everyone in the boat is properly seated. Do not allow anyone to sit or ride on any part of the boat that was not intended for such use. This includes the back of seats, gunwales, transom, bow, decks, raised fishing seats, any rotating fishing seat; or anywhere that an unexpected acceleration, sudden stopping, unexpected loss of boat control, or sudden boat movement could cause a person to be thrown overboard or into the boat.

Never be under the influence of alcohol or drugs while boating (it is the law). Alcohol or drug use impairs your judgment and greatly reduces your ability to react quickly.

Prepare other boat operators. Instruct at least one other person on board in the basics of starting and operating the outboard, and boat handling, in case the driver becomes disabled or falls overboard.

Passenger boarding. Stop the engine whenever passengers are boarding, unloading, or are near the back (stern) of the boat. Just shifting the outboard into neutral is not sufficient.

Be alert. The operator of the boat is responsible by law to maintain a proper lookout by sight and hearing. The operator must have an unobstructed view particularly to the front. No passengers, load, or fishing seats should block the operators view when operating the boat above idle speed.

Never drive your boat directly behind a water skier in case the skier falls. As an example, your boat traveling at 40 km/h (25 MPH) will overtake a fallen skier 61 m (200 ft.) in front of you in 5 seconds.

Watch fallen skiers. When using your boat for water skiing or similar activities, always keep a fallen or down skier on the operator's side of the boat while returning to assist the skier. The operator should always have the down skier in sight and never back up to the skier or anyone in the water.

Report accidents. Boat operators are required by law to file a Boating Accident Report with their state boating law enforcement agency when their boat is involved in certain boating accidents. A boating accident must be reported if 1) there is loss of life or probable loss of life, 2) there is personal injury requiring medical treatment beyond first aid, 3) there is damage to boats or other property where the damage value exceeds \$500.00 or 4) there is complete loss of the boat. Seek further assistance from local law enforcement.

GENERAL INFORMATION

Recording Serial Number

It is important to record this number for future reference. The serial number is located on the outboard as shown.

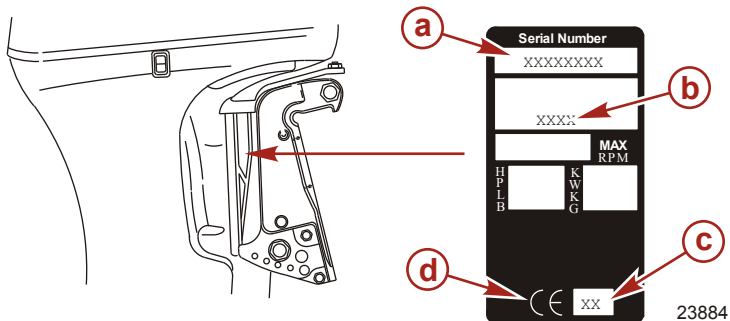

- a- Serial number
- b- Model designation
- c- Year manufactured
- d- Certified Europe Insignia (as applicable)

135/150/175 OptiMax Specifications

Models	135	150	175
Horsepower	135	150	175
Kilowatts	100.7	111.9	130.5
Full Throttle RPM Speed	5000-5500 RPM	5250-5750 RPM	
Idle Speed in Forward Gear	550 ± 25 RPM		
Number of Cylinders	6		
Piston Displacement	2508 cc (153 cu. in.)		
Cylinder Bore	88.4 mm (3.500 in.)		
Piston Stroke	67.3 mm (2.650 in.)		
Recommended Spark Plug	NGK IZFR5G		
Spark Plug Gap	0.8 mm (0.031 in.)		
Standard Gearcase Gear Ratio	2.00:1	1.87:1	
High Altitude Gearcase Gear Ratio	2.30:1	2.00:1	
Recommended Gasoline	Refer to Fuel & Oil		
Recommended Oil	Refer to Fuel & Oil		
Gearcase Lubricant Capacity	665 ml (22.5 fl. oz.)		
Battery Rating	1000 Marine Cranking Amps (MCA) or 800 Cold Cranking Amps (CCA)		
Charging System Output	60 Amps		

GENERAL INFORMATION

Component Identification

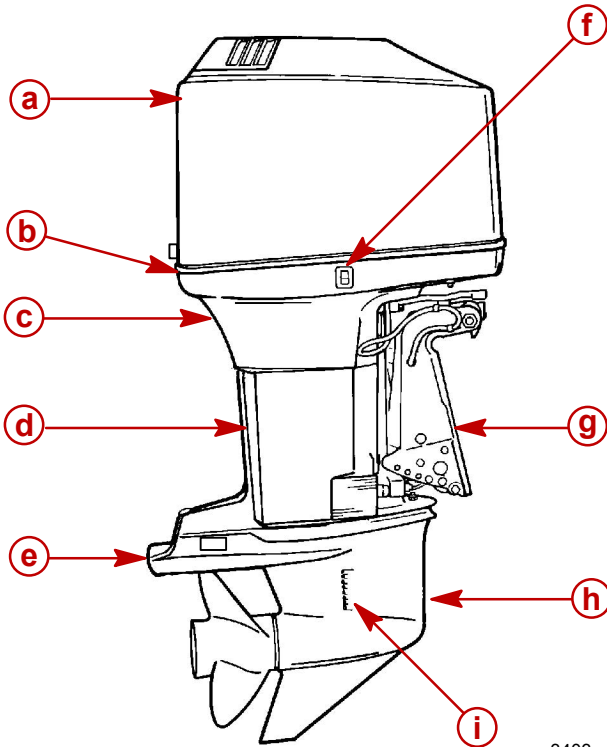

3403

- a** - Top cowl
- b** - Bottom cowl
- c** - Water pump indicator hole
- d** - Driveshaft housing
- e** - Anti-ventilation plate

- f** - Auxiliary tilt switch
- g** - Transom brackets
- h** - Gearcase
- i** - Cooling water intake holes

TRANSPORTING

Trailing Boat/Outboard

Trail your boat with the outboard tilted down in a vertical operating position.

If additional ground clearance is required, the outboard should be tilted up using an accessory outboard support device. Refer to your local dealer for recommendations. Additional clearance may be required for railroad crossings, driveways and trailer bouncing.

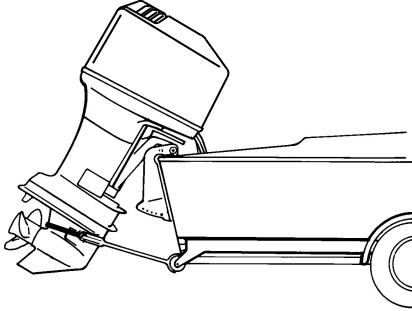

28419

IMPORTANT: Do not rely on the power trim/tilt system or tilt support lever to maintain proper ground clearance for trailering. The outboard tilt support lever is not intended to support the outboard for trailering.

Shift the outboard to forward gear. This prevents the propeller from spinning freely.

FUEL AND OIL

Fuel Recommendations

IMPORTANT: Use of improper gasoline can damage your engine. Engine damage resulting from the use of improper gasoline is considered misuse of the engine, and damage caused thereby will not be covered under the limited warranty.

FUEL RATINGS

Mercury Marine engines will operate satisfactorily when using a major brand of unleaded gasoline meeting the following specifications:

USA and Canada - having a posted pump Octane Rating of 87 (R+M)/2 minimum. Premium gasoline [92 (R+M)/2 Octane] is also acceptable. Do NOT use leaded gasoline.

Outside USA and Canada - having a posted pump Octane Rating of 90 RON minimum. Premium gasoline (98 RON) is also acceptable. If unleaded gasoline is not available, use a major brand of leaded gasoline.

USING REFORMULATED (OXYGENATED) GASOLINES (USA ONLY)

This type of gasoline is required in certain areas of the USA. The 2 types of oxygenates used in these fuels are Alcohol (Ethanol) or Ether (MTBE or ETBE). If Ethanol is the oxygenate that is used in the gasoline in your area, refer to Gasolines Containing Alcohol.

These Reformulated Gasolines are acceptable for use in your Mercury Marine engine.

GASOLINES CONTAINING ALCOHOL

If the gasoline in your area contains either methanol (methyl alcohol) or ethanol (ethyl alcohol), you should be aware of certain adverse effects that can occur. These adverse effects are more severe with methanol. Increasing the percentage of alcohol in the fuel can also worsen these adverse effects.

Some of these adverse effects are caused because the alcohol in the gasoline can absorb moisture from the air, resulting in a separation of the water/alcohol from the gasoline in the fuel tank.

The fuel system components on your Mercury Marine engine will withstand up to 10% alcohol content in the gasoline. We do not know what percentage your boat's fuel system will withstand. Contact your boat manufacturer for specific recommendations on the boat's fuel system components (fuel tanks, fuel lines, and fittings). Be aware that gasolines containing alcohol may cause increased:

- Corrosion of metal parts
- Deterioration of rubber or plastic parts
- Fuel permeation through rubber fuel lines
- Starting and operating difficulties

WARNING

Fuel leakage is a fire or explosion hazard, which can cause serious injury or death. Periodically inspect all fuel system components for leaks, softening, hardening, swelling, or corrosion, particularly after storage. Any sign of leakage or deterioration requires replacement before further engine operation.

Because of possible adverse effects of alcohol in gasoline, it is recommended that only alcohol-free gasoline be used where possible. If only fuel containing alcohol is available, or if the presence of alcohol is unknown, increased inspection frequency for leaks and abnormalities is required.

IMPORTANT: When operating a Mercury Marine engine on gasoline containing alcohol, storage of gasoline in the fuel tank for long periods should be avoided. Long periods of storage, common to boats, create unique problems. In cars, alcohol-blend fuels normally are consumed before they can absorb enough moisture to cause trouble, but boats often sit idle long enough for phase separation to take place. In addition, internal corrosion may take place during storage if alcohol has washed protective oil films from internal components.

Oil Recommendation

Recommended Oil	MercuryOptimax/DFI or Quicksilver DFI 2-Cycle Engine Oil
-----------------	--

FUEL AND OIL

Mercury Optimax/DFI or Quicksilver DFI 2-Cycle Engine Oil is recommended for your engine. If Mercury Optimax/DFI or Quicksilver DFI 2-Cycle engine oil is not available, we recommend using Mercury or Quicksilver TC-W3 Premium Plus 2-Cycle Oil. Severe engine damage may result from use of an inferior oil.

Fuel Additives

To minimize carbon deposit buildup in the engine, it is recommended to add Mercury or Quicksilver Quickleen Engine Treatment additive to the engine's fuel at each tank fill throughout the boating season. Use additive as directed on container.

Fuel Requirements

Do not use pre-mixed gas and oil in this engine. The engine automatically receives extra oil during engine break-in. Use a fresh supply of the recommended gasoline during engine break-in and after engine break-in.

Avoiding Fuel Flow Restriction

IMPORTANT: Adding components to the fuel supply system (filters, valves, fittings, etc.) may restrict the fuel flow. This may cause engine stalling at low speed, and/or a lean fuel condition at high RPM that could cause engine damage.

Filling Remote Oil Tank

Remove filler cap and fill with the specified oil. Oil tank capacity is 11.5 liters (3 gallons). Replace filler cap and tighten securely.

IMPORTANT: Always make sure the oil tank caps are threaded on tight. An air leak will prevent oil flow to the engine.

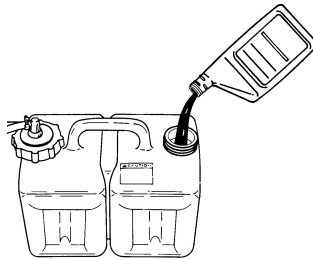

or27

Filling Engine Mounted Oil Reservoir Tank

NOTE: Filling this tank is only necessary if the oil level should ever drop and the low oil warning system is activated.

1. Remove the top cowl.
2. Loosen the fill cap on the engine oil reservoir tank. Run the engine until all the air has been vented out of the oil reservoir tank and tank is filled with oil to the point of overflow.
3. Re-tighten the fill cap. Stop the engine and replace the top cowl.

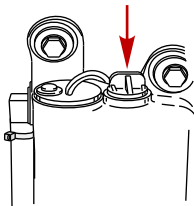

29394

FUEL AND OIL

Filling Fuel Tank

WARNING

Avoid serious injury or death from a gasoline fire or explosion. Use caution when filling fuel tanks. Always stop the engine and do not smoke or allow open flames or sparks in the area while filling fuel tanks.

Fill fuel tanks outdoors away from heat, sparks, and open flames.

Remove portable fuel tanks from boat to refill them.

Always stop engine before refilling tanks.

Do not completely fill the fuel tanks. Leave approximately 10% of the tank volume unfilled. Fuel will expand in volume as its temperature rises and can leak under pressure if the tank is completely filled.

FEATURES AND CONTROLS

Remote Control Features

Your boat may be equipped with one of the Mercury Precision or Quicksilver remote controls shown. If not, consult your dealer for a description of the functions and operations of the remote control.

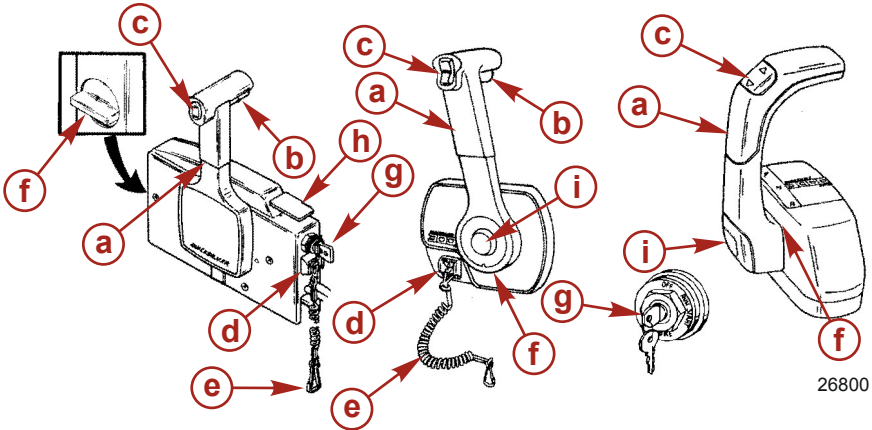

- a - Control handle - forward, neutral, reverse.
- b - Neutral release lever
- c - Trim/tilt switch (if equipped). - Refer to **Features & Controls - Power Trim and Tilt**.
- d - Lanyard stop switch - Refer to **General Information - Lanyard Stop Switch**.
- e - Lanyard - Refer to **General Information - Lanyard Stop Switch**.

- f - Throttle friction adjustment - Console controls require cover removal for adjustment.
- g - Ignition key switch - "OFF," "ON," "START."
- h - Fast idle lever - Refer to **Operation - Starting the Engine**.
- i - Throttle only button - Refer to **Operation - Starting the Engine**.

Warning System

The outboard warning system incorporates a warning horn inside the boat. The warning horn may be located inside the remote control or connected to the ignition key switch.

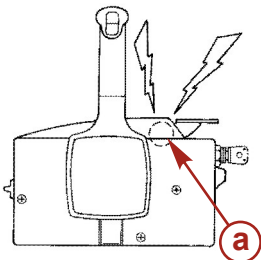

a - Horn inside remote control

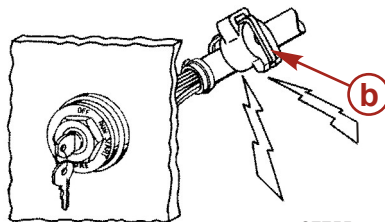

b - Horn connected to ignition key switch

WARNING HORN SIGNALS

When the key switch is turned to the "ON" position, the horn will turn on for a moment as a test to show the horn is working.

FEATURES AND CONTROLS

The warning horn will emit either a continuous beep or intermittent short beeps. This will alert the operator and help identify the following listed situations. For visual display of the specific engine functions and for additional engine data, refer to **SmartCraft Product** information, following.

Warning Horn		
Function	Sound	Description
Start Up	One Beep	Normal System Test
Low Oil Reserve	Four Beeps every 2 Minutes	Oil lever is low in the engine mounted oil reservoir. Refill the engine mounted oil reservoir along with the remote oil tank. Refer to Fuel & Oil .
Water in Fuel	Four Beeps every 2 Minutes	Water in the water separating fuel filter reaches the full level. Water can be removed from the filter. Refer to Maintenance - Fuel System for filter removal.
Cooling System Problem	Continuous	Engine Guardian System is activated. Power limit will vary with level of overheat. Shift outboard into neutral and check for a steady stream of water coming out of the water pump indicator hole. If no water is coming out of the water pump indicator hole or flow is intermittent, stop engine and check water intake holes for obstruction. The Guardian System must be RESET before engine will operate at higher speeds. Moving throttle lever back to idle resets the system.
Oil Level is Critically Low	Continuous	Engine Guardian System is activated. Power will be limited. The oil level is critically low in the engine mounted oil reservoir. Refill the engine mounted oil reservoir along with the remote oil tank.
Oil Pump Failure	Continuous	Engine Guardian System is activated. Power will be limited. The warning horn is activated if the oil pump should ever stop functioning electrically. No lubricating oil is being supplied to the engine.
Engine Overspeed	Continuous	The warning horn is activated any time engine speed exceeds the maximum allowable RPM. The system will limit the engine speed to within the allowable range. Engine overspeed indicates a condition that should be corrected. Overspeed could be caused by incorrect propeller pitch, engine height, trim angle, etc.
Sensor out of Range	Continuous	Engine Guardian System is activated. Power will be limited.
	Intermittent Beep	

ENGINE GUARDIAN SYSTEM

The Engine Guardian System monitors the critical sensors on the engine for any early indications of problems. The system will respond to a problem by emitting a continuous beep and/or reducing engine power in order to provide engine protection.

If Guardian System has been activated, reduce throttle speed. The horn will turn off when throttle speed is within the allowable limit. Consult your dealer for assistance.

FEATURES AND CONTROLS

SMARTCRAFT PRODUCT

A Mercury SmartCraft System instrument package can be purchased for this outboard. A few of the functions the instrument package will display are engine RPM, coolant temperature, battery voltage, fuel consumption and engine operating hours.

The SmartCraft Instrument package will also aid in Engine Guardian diagnostics. The SmartCraft Instrument package will display critical engine alarm data and potential problems.

Power Trim And Tilt

Your outboard has a trim/tilt control called power trim. This enables the operator to easily adjust the position of the outboard by pressing the trim switch. Moving the outboard in closer to the boat transom is called trimming in or down. Moving the outboard further away from the boat transom is called trimming out or up. The term trim generally refers to the adjustment of the outboard within the first 20° range of travel. This is the range used while operating your boat on plane. The term tilt is generally used when referring to adjusting the outboard further up out of the water. With the engine turned off, the outboard can be tilted out of the water. At low idle speed, the outboard can also be tilted up past the trim range to permit, for example, shallow water operation.

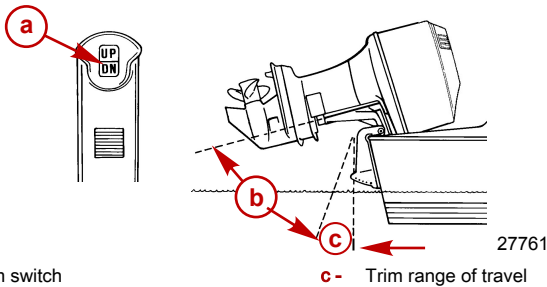

POWER TRIM OPERATION

With most boats, operating around the middle of the trim range will give satisfactory results. However, to take full advantage of the trimming capability there may be times when you choose to trim your outboard all the way in or out. Along with an improvement in some performance aspects comes a greater responsibility for the operator, and this is being aware of some potential control hazards.

The most significant control hazard is a pull or torque that can be felt on the steering wheel or tiller handle. This steering torque results from the outboard being trimmed so that the propeller shaft is not parallel to the water surface.

WARNING

Trimming the outboard beyond a neutral steering condition may result in a pull on the steering wheel or tiller handle and loss of boat control. Maintain control of the boat if trimming beyond a neutral steering condition.

Consider the following lists carefully.

1. Trimming In or Down Can:
 - Lower the bow.
 - Result in quicker planing off, especially with a heavy load or a stern heavy boat.
 - Generally improve the ride in choppy water.
 - Increase steering torque or pull to the right (with the normal right hand rotation propeller).

FEATURES AND CONTROLS

- In excess can lower the bow of some boats to a point where they begin to plow with their bow in the water while on plane. This can result in an unexpected turn in either direction (called bow steering or over-steering) if any turn is attempted, or if a significant wave is encountered.

⚠ WARNING

Operating the boat at high speeds with the outboard trimmed too far under can create excessive bow steer, resulting in the operator losing control of the boat. Install the trim limit pin in a position that prevents excessive trim under and operate the boat in a safe manner.

- In rare circumstances, the owner may decide to limit the trim in. This can be accomplished by purchasing a stainless steel tilt pin from your dealer and inserting it in whatever adjustment hole in the transom brackets is desired. The non-stainless steel shipping bolt should not be used in this application other than on a temporary basis.
2. Trimming Out or Up can:
- Lift the bow higher out of the water.
 - Generally increase top speed.
 - Increase clearance over submerged objects or a shallow bottom.
 - Increase steering torque or pull to the left at a normal installation height (with the normal right hand rotation propeller).
 - In excess can cause boat porpoising (bouncing) or propeller ventilation.
 - Cause engine overheating if any cooling water intake holes are above the water line.

TILTING OPERATION

To tilt outboard, shut off the engine and press the trim/tilt switch or auxiliary tilt switch to the up position. The outboard will tilt up until the switch is released or it reaches its maximum tilt position.

1. Engage the tilt support lever, by rotating knob to bring the support lever upward.
2. Lower outboard to rest on the tilt support lever.
3. Disengage the tilt support lever, by raising the outboard off the support lever and rotating the lever down. Lower the outboard.

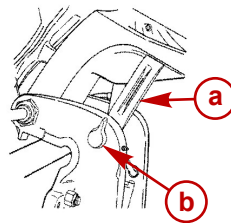

a - Tilt support lever

27778
b - Knob

MANUAL TILTING

If the outboard cannot be tilted using the power trim/tilt switch, the outboard can be manually tilted.

NOTE: The manual tilt release valve must be tightened before operating the outboard to prevent the outboard from tilting up during reverse operation.

FEATURES AND CONTROLS

1. Turn out the manual tilt release valve 3 turns counterclockwise. This allows manual tilting of the outboard. Tilt the outboard to the desired position and tighten the manual tilt release valve.

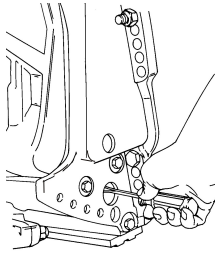

22362

SHALLOW WATER OPERATION

When operating your boat in shallow water, you can tilt the outboard beyond the maximum trim range to prevent hitting bottom.

1. Reduce engine speed below 2000 RPM.
2. Tilt outboard up. Make sure all the water intake holes stay submerged at all times.
3. Operate the engine at slow speed only. If engine speed exceeds 2000 RPM, the outboard will automatically return down to the maximum trim range.

AUXILIARY TILT SWITCH

The auxiliary tilt switch can be used to tilt the outboard up or down using the power trim system.

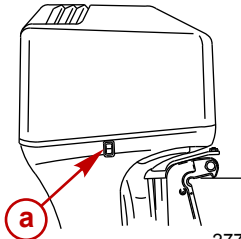

27779

a - Auxiliary tilt switch

OPERATION

Pre-Starting Check List

- Operator knows safe navigation, boating, and operating procedures.
- An approved personal flotation device of suitable size for each person aboard and readily accessible (it is the law).
- A ring type life buoy or buoyant cushion designed to be thrown to a person in the water.
- Know the boat's maximum load capacity. Look at the boat capacity plate.
- Fuel supply OK.
- Oil supply (oil injection) OK.
- Arrange passengers and load in the boat so the weight is distributed evenly and everyone is seated in a proper seat.
- Tell someone where you are going and when you expect to return.
- It is illegal to operate a boat while under the influence of alcohol or drugs.
- Know the waters and area you will be boating; tides, currents, sand bars, rocks, and other hazards.
- Make inspection checks listed in **Maintenance - Inspection and Maintenance Schedule**.

Operating In Freezing Temperatures

When using your outboard or having your outboard moored in freezing or near freezing temperatures, keep the outboard tilted down at all times so the gearcase is submerged. This prevents trapped water in gearcase from freezing and causing possible damage to the water pump and other components.

If there is a chance of ice forming on the water, the outboard should be removed and drained completely of water. If ice should form at the water level inside the outboard driveshaft housing, it will block water flow to the engine causing possible damage.

Operating In Salt Water Or Polluted Water

We recommend that you flush the internal water passages of your outboard with fresh water after each use in salt or polluted water. This will prevent a buildup of deposits from clogging the water passages. Refer to **Maintenance - Flushing The Cooling System**.

If you keep your boat moored in the water, always tilt the outboard so the gearcase is completely out of water (except in freezing temperatures) when not in use.

Wash the outboard exterior and flush out the exhaust outlet of the propeller and gearcase with fresh water after each use. Each month, spray Mercury Precision or Quicksilver Corrosion Guard on external metal surfaces. Do not spray on corrosion control anodes as this will reduce the effectiveness of the anodes.

Operating at High Elevations

Your engine automatically compensates for high elevation changes. A different pitch propeller may help reduce some normal performance loss resulting from reduced oxygen in the air. Consult your dealer.

OPERATION

Setting Trim Angle While Running Engine at Idle Speed

The exhaust relief hole on the outboard may become submerged if the outboard is trimmed full-in while running at idle speed. This will cause exhaust restriction, rough idle, excessive smoke, and fouled spark plugs. If this condition exists, trim the outboard up until the exhaust relief hole is out of the water. The outboard should be lowered for accelerating from a standing start or from idle speed.

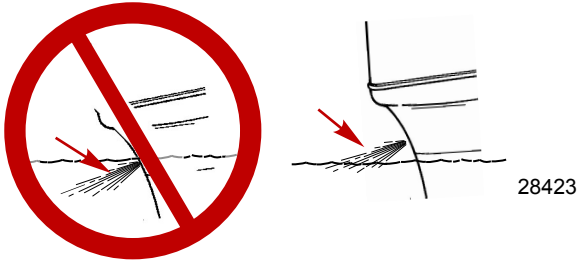

Engine Break-in Procedure

IMPORTANT: Failure to follow the engine break-in procedures can result in poor performance throughout the life of the engine and can cause engine damage. Always follow break-in procedures.

GASOLINE/OIL BREAK-IN MIXTURE

NOTE: Do not use pre-mixed gas and oil during break-in. Use straight gasoline during engine break-in and after engine break-in.

The engine break-in procedure for an OptiMax outboard is important to ensure proper performance and maximum life from the engine. The following break-in procedure allows the internal engine parts to wear-in evenly. Incorrect engine break-in can shorten the engine life.

The engine automatically receives extra oil during the first hours of operation. For most boaters this extra oil mode will be complete in about ten hours.

BREAK-IN PROCEDURE

1. For the first hour of operation, allow the engine to warm up for 30-60 seconds.
 - a. Run the engine at varied throttle settings, the majority of the time between 3000 and 4500 RPM or three-quarter throttle.
 - b. Change engine speed approximately every two minutes, and avoid continuous operation at idle speed for more than ten minutes. Short bursts of full throttle for periods up to ten seconds are acceptable.
 - c. Avoid trimming the outboard out (up) beyond a vertical trim position during operation.

NOTE: It is the driver's responsibility to always drive in a safe manner. Improper trim angle of the outboard when driving at speed can be difficult and dangerous. The purpose of specifying trim angle is to help guide the operator in determining how to put the propel load on the engine. They are intended to be guidelines and do not suggest or require unsafe boat operation.

2. For the next three hours of operation, change engine speed every ten minutes.

Starting The Engine

Before starting, read the Pre-Starting Check List, Special Operating Instructions, and Engine Break-in Procedure in the Operation Section.

OPERATION

NOTICE

Failure to provide sufficient cooling water will damage the water pump and cause the engine to overheat. Provide a sufficient supply of water at the water inlets during operation.

1. Lower the outboard to the vertical operating position. Make sure all cooling water intake holes are submerged.

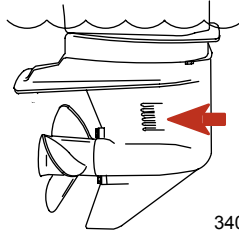

3405

2. Open fuel tank vent screw (in filler cap) on manual venting type fuel tanks.

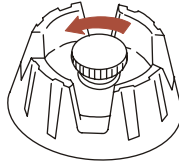

19748

3. Position the fuel line primer bulb so the arrow on the side of the bulb is pointing up. Squeeze the fuel line primer bulb several times until it feels firm.

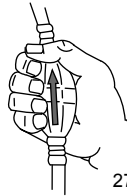

27348

4. Set the lanyard stop switch to "RUN" position. Refer to **General Information - Lanyard Stop Switch**.



19791

OPERATION

5. Shift outboard to neutral (N) position.

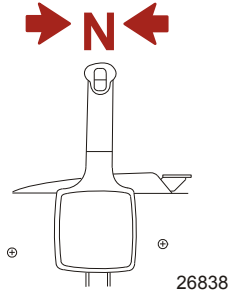

6. For initial start of a new engine or for an engine that ran out of fuel, or was drained of fuel, the fuel system should be filled as follows:
- Squeeze the fuel line primer bulb until it feels firm.
 - Turn the ignition key switch to the "ON" position for three seconds. This operates the electric fuel pump.
 - Turn the ignition key switch back to the "OFF" position, and squeeze the primer bulb again until it feels firm. Turn the ignition key switch to the "ON" position again for three seconds. Continue this procedure until the fuel line primer bulb stays firm.
7. Do not advance the neutral fast idle speed feature on the remote control for starting.

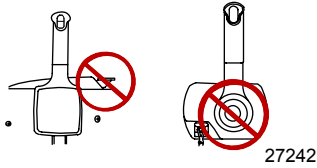

8. Turn the ignition key to "START" position. Release the key when engine starts. If engine fails to start in 10 seconds, return the key to "OFF" position, wait one second and try again.

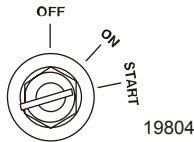

NOTE: The electronic starting system will automatically prime (choke) the engine and increase idle speed for starting.

9. Check for a steady stream of water flowing out of the water pump indicator hole.

IMPORTANT: If no water is coming out of the water pump indicator hole, stop engine and check cooling water intake holes for obstruction. No obstruction may indicate a water pump failure or blockage in the cooling system. This condition will cause the engine to overheat. Have the outboard checked by your dealer. Operating the engine while overheated will cause engine damage.

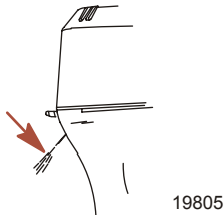

OPERATION

Gear Shifting

IMPORTANT: Observe the following:

- **Never shift outboard into gear unless engine speed is at idle.**
- **Do not shift outboard into reverse when the engine is not running.**
- Your outboard has three gear shift positions to provide operation. Forward (F), Neutral (N) and Reverse (R).
- When shifting, always stop at neutral position and allow the engine speed to return to idle.
- Always shift outboard into gear with a quick motion.
- After shifting outboard into gear, advance the lever further to increase speed.

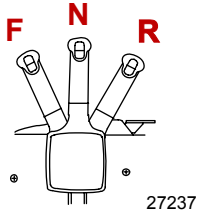

Stopping The Engine

Reduce engine speed and shift outboard to neutral position. Turn ignition key to "OFF" position.

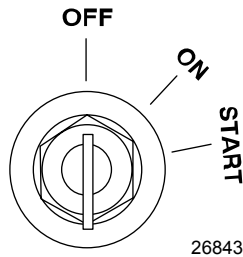

MAINTENANCE

Outboard Care

To keep your outboard in the best operating condition, it is important that your outboard receive the periodic inspections and maintenance listed in the **Inspection and Maintenance Schedule**. We urge you to keep it maintained properly to ensure the safety of you and your passengers, and retain its dependability.

Record maintenance performed in the **Maintenance Log** at the back of this book. Save all maintenance work orders and receipts.

SELECTING REPLACEMENT PARTS FOR YOUR OUTBOARD

We recommend using original Mercury Precision or Quicksilver replacement parts and Genuine Lubricants.

EPA Emissions

EMISSION CERTIFICATION LABEL

An emission certification label, showing emission levels and engine specifications directly related to emissions, is placed on the engine at time of manufacture.

MERCURY		EMISSION CONTROL INFORMATION	
This engine conforms to <input type="checkbox"/> model year EPA regulations for Marine SI engines. Refer to Owner's Manual for required maintenance.			
a →	IDLE SPEED: <input type="text"/>	FAMILY: <input type="text"/>	f →
b →	<input type="text"/> hp	<input type="text"/> cc	g →
c →	TIMING (IN DEGREES): <input type="text"/>	FEL: <input type="text"/> g/kWh	h →
d →	Standard spark plug: <input type="text"/>	<input type="text"/>	i →
	Suppressor spark plug: <input type="text"/>		
	GAP: <input type="text"/>		
e →	Valve Clearance (Cold) mm	Intake <input type="text"/>	
		Exhaust <input type="text"/>	

28405

- | | |
|--|--|
| a - Idle speed | f - Family number |
| b - Engine horsepower | g - Maximum emission output for the engine family |
| c - Timing specification | h - Piston placement |
| d - Recommended spark plug and gap | i - Date of manufacture |
| e - Valve clearance (if applicable) | |

OWNER RESPONSIBILITY

The owner/operator is required to have routine engine maintenance performed to maintain emission levels within prescribed certification standards.

The owner/operator is not to modify the engine in any manner that would alter the horsepower or allow emissions levels to exceed their predetermined factory specifications.

Inspection And Maintenance Schedule

BEFORE EACH USE

- Check that lanyard stop switch stops the engine.
- Visually inspect the fuel system for deterioration or leaks.
- Check outboard for tightness on transom.
- Check steering system for binding or loose components.
- Visually check steering link rod fasteners for proper tightness. See **Steering Link Rod Fasteners**.
- Check propeller blades for damage.

MAINTENANCE

AFTER EACH USE

- Flush out the outboard cooling system if operating in salt or polluted water. See **Flushing the Cooling System**.
- Wash off all salt deposits and flush out the exhaust outlet of the propeller and gearcase with fresh water if operating in salt water.

EVERY 100 HOURS OF USE OR ONCE YEARLY, WHICHEVER OCCURS FIRST

- Lubricate all lubrication points. Lubricate more frequently when used in salt water. See **Lubrication Points**.
- Replace spark plugs at first 100 hours or first year. After that, inspect spark plugs every 100 hours or once yearly. Replace spark plugs as needed. See **Spark Plug Inspection and Replacement**.
- Replace water separating fuel filter. See **Fuel System**.
- Replace compressor air intake filter. See **Compressor Air Intake Filter**.
- Inspect alternator belt. See **Alternator Belt Inspection**.
- Check corrosion control anodes. Check more frequently when used in salt water. See **Corrosion Control Anodes**.
- Drain and replace gearcase lubricant. See **Gearcase Lubrication**.
- Check power trim fluid. See **Checking Power Trim Fluid**.
- Inspect battery. See **Battery Inspection**.
- Check control cable adjustments.¹
- Lubricate splines on the driveshaft and shift shaft.¹
- Check tightness of bolts, nuts, and other fasteners.
- Replace water pump impeller (more often if overheating occurs or reduced water pressure is noted).¹
- Check cowl seals to make sure seals are intact and not damaged.
- Check internal cowl sound reduction foam (if equipped) to make sure foam is intact and not damaged.
- Check that the intake silencer (if equipped) is in place.
- Check that the idle relief muffler (if equipped) is in place.
- Check for loose hose clamps and rubber boots (if equipped) on the air intake assembly.

BEFORE PERIODS OF STORAGE

- Refer to Storage procedure. See **Storage** section.

Flushing The Cooling System

Flush the internal water passages of the outboard with fresh water after each use in salt, polluted, or muddy water. This will help prevent a buildup of deposits from clogging the internal water passages.

NOTE: Engine can be stopped or running at idle speed when flushing the cooling system. Do not flush engine using a water system that exceeds 310.26 kPa (45 psi)

1. These items should be serviced by an authorized dealer.

MAINTENANCE

1. Remove the plug from fitting in the bottom cowl.

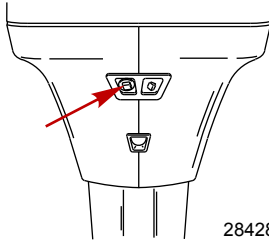

28428

2. Attach a water hose to the fitting. Turn on the water and flush for 3 to 5 minutes.

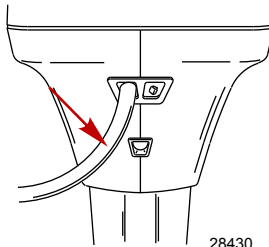

28430

Top Cowl Removal And Installation

REMOVAL

1. Pull out the front cowl latch.

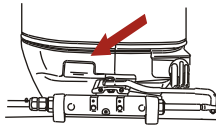

27816

2. Lift up the rear cowl latch. Remove the top cowl.

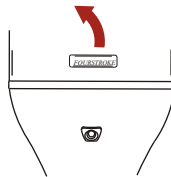

27817

INSTALLATION

1. Lower top cowl into position over engine.
2. Push down the rear cowl latch to lock down the rear and push in the front cowl latch to lock down the front.

Cleaning Care for Top Cowl

IMPORTANT: Dry wiping (wiping the plastic surface when it is dry) will result in minor surface scratches. Always wet the surface before cleaning. Follow cleaning and waxing procedure.

MAINTENANCE

CLEANING AND WAXING PROCEDURE

1. Before washing, rinse the top cowl with clean water to remove dirt and dust that may scratch the surface.
2. Wash the top cowl with clean water and a mild non-abrasive soap. Use a soft clean cloth when washing.
3. Dry thoroughly with a soft clean cloth.
4. Wax the surface using a non-abrasive automotive polish (polish designed for clear coat finishes). Remove the applied wax by hand using a clean soft cloth.

Flywheel Cover Removal and Installation

REMOVAL

1. Remove the flywheel cover by lifting off.
2. Pull out the vent hose.

INSTALLATION

1. Install flywheel cover as follows:
 - a. Place cover onto the front flange.
 - b. Push rear of the cover down onto the rear pin and air intake tube for the air compressor.
 - c. Insert vent hose into hole.

IMPORTANT: Make sure the flywheel cover is pushed down on the air intake tube for the air compressor.

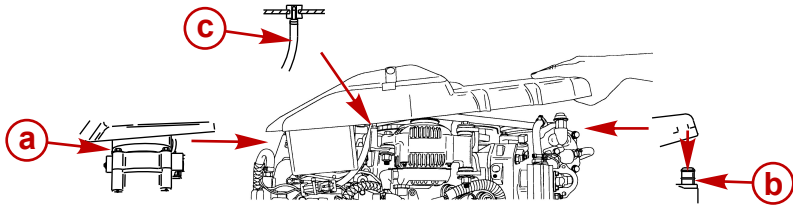

- a -** Front flange
b - Air intake tube

- c -** Vent hose

29395

Fuel System

⚠ WARNING

Fuel is flammable and explosive. Ensure the key switch is off and the lanyard is positioned so that the engine cannot start. Do not smoke or allow sources of spark or open flame in the area while servicing. Keep the work area well ventilated and avoid prolonged exposure to vapors. Always check for leaks before attempting to start the engine and wipe up any spilled fuel immediately.

Before servicing any part of the fuel system, stop engine and disconnect the battery. Drain the fuel system completely. Use an approved container to collect and store fuel. Wipe up any spillage immediately. Material used to contain spillage must be disposed of in an approved receptacle. Any fuel system service must be performed in a well ventilated area. Inspect any completed service work for sign of fuel leakage.

FUEL LINE INSPECTION

Visually inspect the fuel line and primer bulb for cracks, swelling, leaks, hardness, or other signs of deterioration or damage. If any of these conditions are found, the fuel line or primer bulb must be replaced.

MAINTENANCE

WATER SEPARATING FUEL FILTER

NOTE: The warning system will turn on when water in the fuel filter reaches the full level. See **Features & Controls - Warning System**.

The water separating fuel filter removes moisture and also debris from the fuel. If the filter becomes filled with water, the water can be removed. If the filter becomes plugged with debris, the filter must be replaced with a new filter.

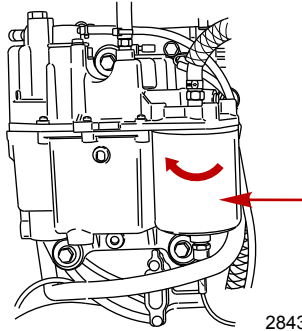

28434

1. Remove and replace filter as follows:
 - a. Turn ignition key switch to "OFF" position.
 - b. Disconnect wire at bottom of filter.
 - c. Remove filter by turning the filter clockwise. Tip the filter to drain fluid in a suitable container.
 - d. Lubricate the sealing ring on the filter with oil. Thread on the filter and tighten securely by hand. Reconnect the wire to the filter.

IMPORTANT: Visually inspect for fuel leakage from the filter by squeezing the primer bulb until firm, forcing fuel into the filter.

Steering Link Rod Fasteners

IMPORTANT: The steering link rod that connects the steering cable to the engine must be fastened using special washer head bolt ("a" - Part Number 10-849838) and self-locking nylon insert locknuts ("c" & "d" - Part Number 11-826709113). These locknuts must never be replaced with common nuts (non-locking) as they will work loose and vibrate off freeing the link rod to disengage.

MAINTENANCE

⚠ WARNING

Improper fasteners or improper installation procedures can result in loosening or disengagement of the steering link rod. This can cause a sudden, unexpected loss of boat control, resulting in serious injury or death due to occupants being thrown within or out of the boat. Always use required components and follow instructions and torque procedures.

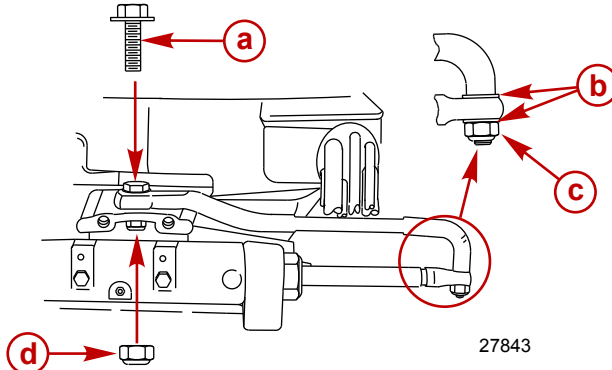

a - Special washer head bolt (10-849838)

b - Flat washer (2)

c - Nylon insert locknut (11-826709113)

d - Nylon insert locknut (11-826709113)

Description	Nm	lb. in.	lb. ft.
Special washer head bolt	27		20
Nylon insert locknut "d"	27		20
Nylon insert locknut "c"	Tighten until seats, then back off 1/4 turn		

Assemble steering link rod to steering cable with two flat washers and self-locking nylon insert locknut. Tighten locknut until it seats, then back nut off 1/4 turn.

Assemble steering link rod to engine with special washer head bolt and self-locking nylon insert locknut. First torque bolt, then torque locknut to specifications.

Fuse Replacement

IMPORTANT: Always carry spare 5 and 20 AMP fuses.

The electrical wiring circuits on the outboard are protected from overload by fuses in the wiring. If a fuse is blown, try to locate and correct the cause of the overload. If the cause is not found, the fuse may blow again.

MAINTENANCE

Open the fuse holder and look at the silver colored band inside the fuse. If band is broken, replace the fuse. Replace fuse with a new fuse with the same rating.

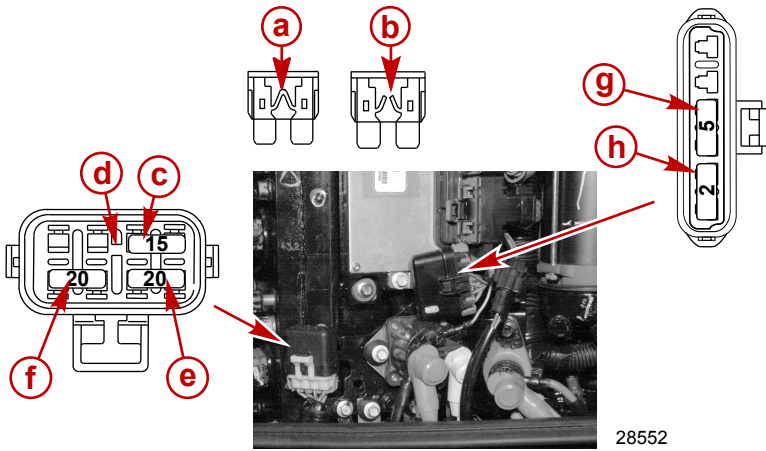

- a - Good fuse
- b - Blown fuse
- c - Main power relay - 15 amp fuse
- d - Spare fuse slot

- e - Ignition system circuit - 20 amp fuse
- f - Electric fuel pump/ECM driver power/ injectors/oil pump circuit - 20 amp fuse
- g - Power to 10-pin SmartCraft connector - 5 amp fuse
- h - Diagnostic circuit 4-pin connector - 2 amp fuse

Corrosion Control Anode

Your outboard has corrosion control anodes at different locations. An anode helps protect the outboard against galvanic corrosion by sacrificing its metal to be slowly eroded instead of the outboard metals. Each anode requires periodic inspection, especially in salt water which will accelerate the erosion. To maintain this corrosion protection, always replace the anode before it is completely eroded. Never paint or apply a protective coating on the anode as this will reduce effectiveness of the anode.

The gearcase has two corrosion control anodes, one on each side. A third anode is installed on the bottom of the transom bracket assembly.

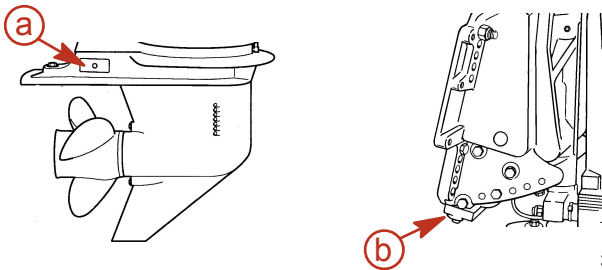

- a - Anode (2) on each side of gearcase

- b - Anode on transom bracket assembly

Battery Inspection

The battery should be inspected at periodic intervals to ensure proper engine starting capability.

IMPORTANT: Read the safety and maintenance instructions which accompany your battery.

MAINTENANCE

1. Turn off the engine before servicing the battery.
2. Add water as necessary to keep the battery full.
3. Make sure the battery is secure against movement.
4. Battery cable terminals should be clean, tight, and correctly installed. Positive to positive and negative to negative.
5. Make sure the battery is equipped with a non-conductive shield to prevent accidental shorting of battery terminals.

Battery Information

WARNING

Failure to properly secure the battery leads can result in a loss of power to the Digital Throttle and Shift (DTS) system, leading to serious injury or death due to loss of boat control. Secure the battery leads to the battery posts with hex nuts to avoid loose connections.

- Do not use deep cycle batteries. Engines must use a marine starting battery with 1000 MCA, 800 CCA or 180 Ah.
- When connecting engine battery, hex nuts must be used to secure battery leads to battery posts. Torque nuts to specification.

Description	Nm	lb. in.	lb. ft.
Hex nuts	13.5	120	

IMPORTANT: Battery cable size and length is critical. Refer to engine installation manual for size requirements.

Decal needs to be placed on or near battery box for future service reference. One 5/16 in. and one 3/8 in. hex nut are supplied per battery for wing nut replacement. Metric hex nuts are not supplied.

NOTICE - DTS & Optimax Engines

DO NOT USE DEEP CYCLE BATTERIES!
DTS (Digital Throttle and Shift) applications and Optimax engines must use a marine starting battery with 1000 MCA, 800 CCA, or 180 Ah. rating.

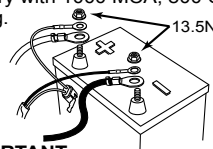

13.5Nm (120 lbs. in.)



DO NOT USE WING NUTS.

IMPORTANT:
Battery cable size and length is critical. Refer to engine installation manual for size requirements.
37-895387

Place decal on or near battery box for future service reference. 5/16" and 3/8" hex nuts supplied for wing nut replacement. Metric hex nuts not supplied.

3486

MAINTENANCE

Propeller Replacement

WARNING

Rotating propellers can cause serious injury or death. Never operate the boat out of the water with a propeller installed. Before installing or removing a propeller, place the drive unit in neutral and engage the lanyard stop switch to prevent the engine from starting.

1. Shift outboard to neutral (N) position.

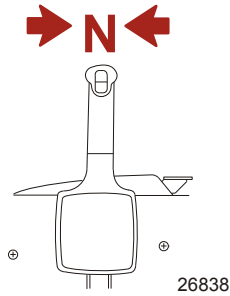

IMPORTANT: Refer to Spark Plug Inspection and Replacement for removing spark plug leads.

2. Remove spark plug leads to prevent engine from starting.

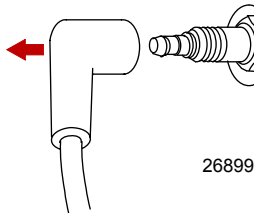

3. Straighten the bent tabs on the propeller nut retainer.

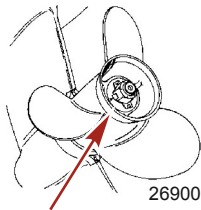

MAINTENANCE

- Place a block of wood between gearcase and propeller to hold propeller and remove propeller nut.

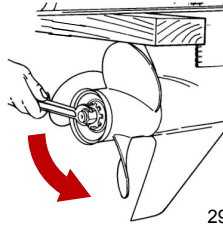

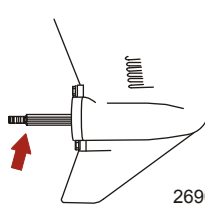

29592

- Pull propeller straight off shaft. If propeller is seized to the shaft and cannot be removed, have the propeller removed by an authorized dealer.
- Coat the propeller shaft with Quicksilver or Mercury Precision Lubricants Anti-Corrosion Grease or 2-4-C with Teflon.



26902

Tube Ref No.	Description	Where Used	Part No.
 94	Anti-Corrosion Grease	Propeller shaft	92-802867 Q1
 95	2-4-C with Teflon	Propeller shaft	92-802859Q1

IMPORTANT: To prevent the propeller hub from corroding and seizing to the propeller shaft (especially in salt water), always apply a coat of the recommended lubricant to the entire propeller shaft at the recommended maintenance intervals and also each time the propeller is removed.

- Flo-Torq I Drive Hub Propellers - Install forward thrust hub, propeller, continuity washer, rear thrust hub, propeller nut retainer, and propeller nut onto the shaft.

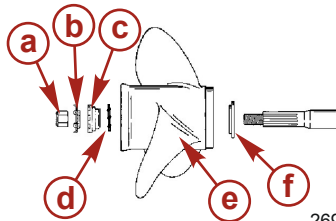

26908

- | | |
|-----------------------------------|----------------------------------|
| a - Propeller nut | d - Continuity washer |
| b - Propeller nut retainer | e - Propeller |
| c - Rear thrust hub | f - Forward thrust washer |

MAINTENANCE

8. Flo-Torq II Drive Hub Propellers - Install forward thrust hub, replaceable drive sleeve, propeller, thrust hub, propeller nut retainer and propeller nut onto the shaft.

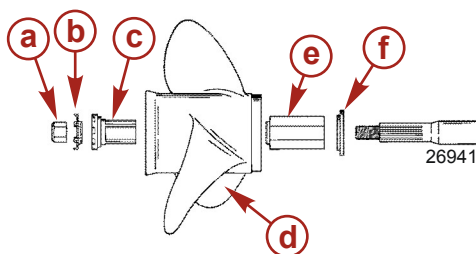

- a** - Propeller nut
b - Propeller nut retainer
c - Rear thrust hub
d - Propeller
e - Replaceable drive sleeve
f - Forward thrust hub

9. Place a block of wood between gearcase and propeller and torque propeller nut to specifications.

Description	Nm	lb. in.	lb. ft.
Propeller nut	75		55

10. Secure propeller nut by bending three of the tabs into the thrust hub grooves.

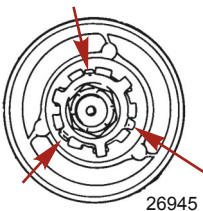

Spark Plug Inspection And Replacement

⚠ WARNING

Damaged spark plug boots may emit sparks which can ignite fuel vapors under the engine cowl, resulting in serious injury or death from a fire or explosion. To avoid damaging the spark plug boots, do not use any sharp object or metal tool to remove the spark plug boots.

1. Remove the spark plug leads. Twist the rubber boots slightly and pull off.

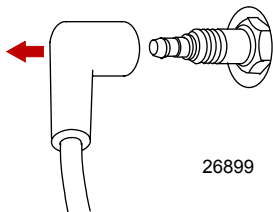

MAINTENANCE

- Remove the spark plugs to inspect. Replace spark plug if electrode is worn or the insulator is rough, cracked, broken, blistered or fouled.

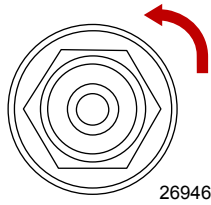

- Set the spark plug gap to specification.

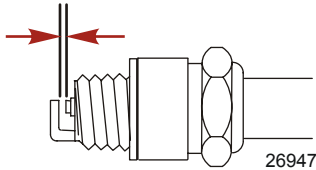

Spark Plug	
Spark plug gap	0.80 mm (0.031 in.)

- Before installing spark plugs, clean off any dirt on the spark plug seats. Install plugs finger tight, and then tighten 1/4 turn or torque to specifications.

Description	Nm	lb. in.	lb. ft.
Spark plug	27		20

Compressor Air Intake Filter

The filter should be changed every 100 hours of operation, or once a season.

IMPORTANT: Never run the engine without the air filter.

REMOVAL

- Remove flywheel cover from engine.

MAINTENANCE

2. Snap out the retainer and remove filter.

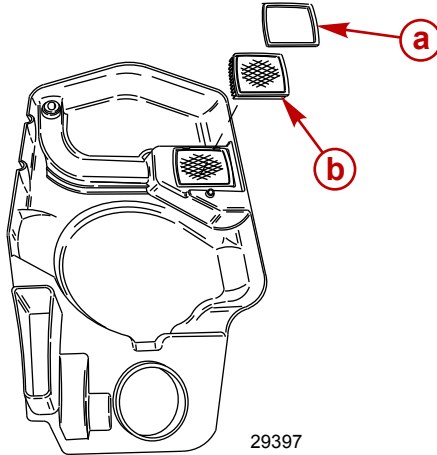

a - Retainer

b - Filter

INSTALLATION

1. Install filter into cover.
2. Secure filter into cover with retainer.

Alternator Belt Inspection

1. Inspect the alternator belt and have it replaced by an authorized dealer if any of the following conditions are found.
 - a. Cracks or deterioration in the rubber portion of the belt.
 - b. Belt surfaces rough or uneven.
 - c. Signs of wear on edges or outer surfaces of belt.

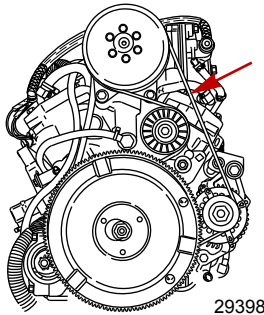

Lubrication Points

1. Lubricate the following with Quicksilver or Mercury Precision Special Lubricant 101.

Tube Ref No.	Description	Where Used	Part No.
 34	Special Lubricant 101	Trim rod ball ends	92-802865Q02

MAINTENANCE

- Trim Rod Ball Ends - Turn the ball ends to work the lubricant into the ball sockets.

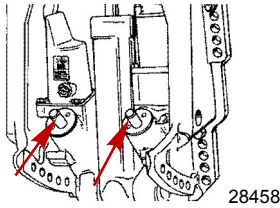

2. Lubricate the following with Quicksilver or Mercury Precision Lubricants Anti-Corrosion Grease or 2-4-C with Teflon.



Tube Ref No.	Description	Where Used	Part No.
 94	Anti-Corrosion Grease	Propeller shaft	92-802867 Q1

Tube Ref No.	Description	Where Used	Part No.
 95	2-4-C with Teflon	Propeller shaft	92-802859Q1

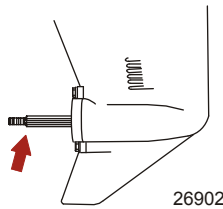
- Propeller Shaft - Refer to **Propeller Replacement** for removal and installation of the propeller. Coat the entire propeller shaft with lubricant to prevent the propeller hub from corroding and seizing to the shaft.



3. Lubricate the following with Quicksilver or Mercury Precision Lubricants 2-4-C with Teflon or Special Lubricant 101.

Tube Ref No.	Description	Where Used	Part No.
 34	Special Lubricant 101	Alternator belt tensioner pivot shaft, swivel bracket, tilt support lever, tilt tube, steering cable	92-802865Q02
 95	2-4-C with Teflon	Alternator belt tensioner pivot shaft, swivel bracket, tilt support lever, tilt tube, steering cable	92-802859Q1

MAINTENANCE

- Alternator Belt Tensioner Pivot Shaft - Lubricate through fitting.

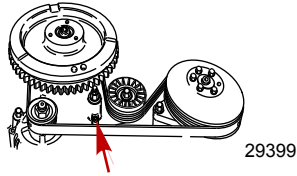

- Swivel Bracket - Lubricate through fitting.
- Tilt Support Lever - Lubricate through fitting.

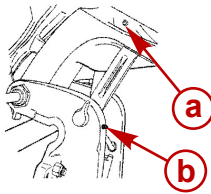

a - Swivel bracket

b - Tilt support lever

- Tilt Tube - Lubricate through fitting.

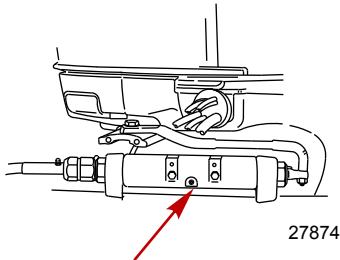

WARNING

Incorrect cable lubrication can cause hydraulic lock, leading to serious injury or death from loss of boat control. Completely retract the end of the steering cable before applying lubricant.

- Steering Cable - Rotate steering wheel to fully retract the steering cable end into the outboard tilt tube. Lubricate through fitting.

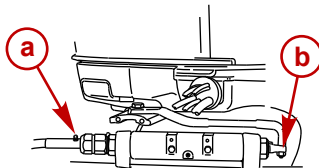

a - Fitting

b - Cable end

MAINTENANCE

- Lubricate the following with Light Weight Oil.
 - Steering Link Rod Pivot Points - Lubricate pivot points.

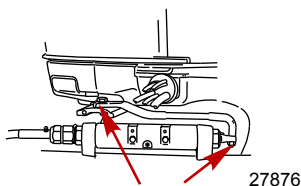

Gearcase Lubrication

When adding or changing gearcase lubricant, visually check for the presence of water in the lubricant. If water is present, it may have settled to the bottom and will drain out prior to the lubricant, or it may be mixed with the lubricant, giving it a milky colored appearance. If water is noticed, have the gearcase checked by your dealer. Water in the lubricant may result in premature bearing failure or, in freezing temperatures, will turn to ice and damage the gearcase.

Examine the drained gearcase lubricant for metal particles. A small amount of metal particles indicates normal gear wear. An excessive amount of metal filings or larger particles (chips) may indicate abnormal gear wear and should be checked by an authorized dealer.

DRAINING GEARCASE

- Place outboard in a vertical operating position.
- Place drain pan below outboard.
- Remove vent plug and fill/drain plug and drain lubricant.

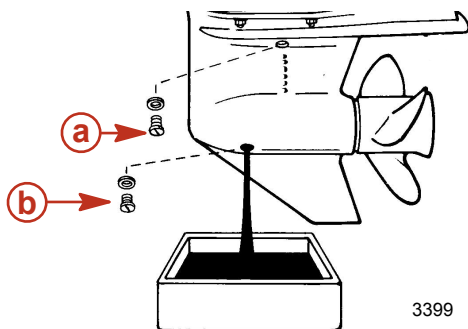

a - Vent plug

b - Fill/drain plug

GEARCASE LUBRICANT CAPACITY

Gearcase lubricant capacity is approximately 666 ml (22.5 fl. oz.).

GEARCASE LUBRICANT RECOMMENDATION

Mercury or Quicksilver High Performance Gear Lubricant.

CHECKING LUBRICANT LEVEL AND REFILLING GEARCASE

- Place outboard in a vertical operating position.
- Remove vent plug.

MAINTENANCE

3. Remove fill/drain plug. Place lubricant tube into the fill hole and add lubricant until it appears at the vent hole.

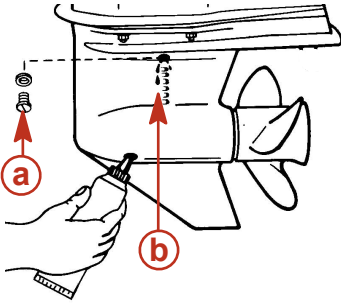

- a- Vent plug
- b- Vent hole

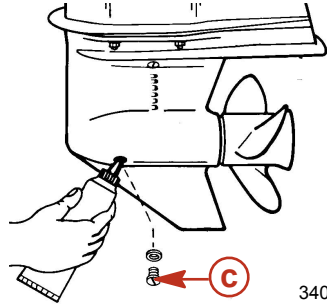

- c- Fill/drain plug

3400

IMPORTANT: Replace sealing washers if damaged.

4. Stop adding lubricant. Install the vent plug and sealing washer before removing the lubricant tube.
5. Remove lubricant tube and reinstall cleaned fill/drain plug and sealing washer.

Submerged Outboard

A submerged outboard will require service within a few hours by an authorized dealer once the outboard is recovered from the water. This immediate attention by a servicing dealer is necessary once the engine is exposed to the atmosphere to minimize internal corrosion damage to the engine.

STORAGE

Storage Preparation

The major consideration in preparing your outboard for storage is to protect it from rust, corrosion, and damage caused by freezing of trapped water.

The following storage procedures should be followed to prepare your outboard for out of season storage or prolonged storage (two months or longer).

NOTICE

Failure to provide sufficient cooling water will damage the water pump and cause the engine to overheat. Provide a sufficient supply of water at the water inlets during operation.

FUEL SYSTEM

IMPORTANT: Gasoline containing alcohol (ethanol or methanol) can cause a formation of acid during storage and can damage the fuel system. If the gasoline being used contains alcohol, it is advisable to drain as much of the remaining gasoline as possible from the fuel tank, remote fuel line, and engine fuel system.

The most effective method for storage preparation is to add the recommended amount of Mercury Precision fuel Stabilizer and Mercury Precision Quickleen products as described on their containers to the fuel tank before the last operation of the boat. Adding Fuel Stabilizer will help prevent the formation of varnish and gum in the gasoline. The Mercury Precision Quickleen product will help clean and lubricate the fuel injectors.

1. Portable Fuel Tank - Pour the required amount of gasoline stabilizer (follow instructions on container) into fuel tank. Tip fuel tank back and forth to mix stabilizer with the fuel.
2. Permanently Installed Fuel Tank - Pour the required amount of gasoline stabilizer (follow instructions on container) into a separate container and mix with approximately one quart (one liter) of gasoline. Pour this mixture into fuel tank.
3. Remove the water separating fuel filter from the engine. Empty the fuel into a suitable container and discard the filter properly.
4. Premix the following in a container:
 - 8 cc (0.27 oz.) or two teaspoons of Mercury Precision Quickleen lubricant.
 - 8 cc (0.27 oz.) or two teaspoons of Mercury Precision Fuel Stabilizer.
5. Pour this mixture in a new water separating fuel filter. Reinstall the fuel filter.
6. Prime the fuel system as outlined in the **Operation - Starting the Engine**.
7. Place the outboard in water or use the flushing attachment for circulating cooling water. Start the engine and run at idle speed for 10 minutes to allow the treated fuel to fill the fuel system.

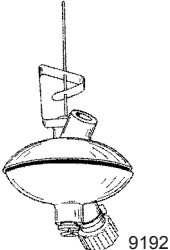
Flushing Device	91-44357Q 2
	Attaches to the water intakes; provides a fresh water connection when flushing the cooling system or operating the engine.

Protecting Internal Engine Components

NOTE: Make sure the fuel system has been prepared for storage. Refer to **Fuel System**, preceding.

IMPORTANT: Refer to **Spark Plug Inspection and Replacement** for correct procedure for removing spark plug leads.

STORAGE

1. Remove the spark plugs. Add approximately 30 ml (1 oz.) of engine oil or inject a five second spray of storage seal into each spark plug hole.
2. Rotate the flywheel manually several times to distribute the oil or storage seal in the cylinders.
3. Re-install spark plugs.

Protecting External Outboard Components

- Lubricate all outboard components listed in **Maintenance - Inspection and Maintenance Schedule**.
- Touch up any paint nicks. See your dealer for touch-up paint.
- Spray Quicksilver or Mercury Precision Lubricants Corrosion Guard on external metal surfaces (except corrosion control anodes).

Tube Ref No.	Description	Where Used	Part No.
 120	Corrosion Guard	External metal surfaces	92-802878Q55

Gearcase

- Drain and refill the gearcase lubricant (refer to **Maintenance - Gearcase Lubrication**).

Positioning Outboard For Storage

Store outboard in an upright (vertical) position to allow water to drain out of outboard.

NOTICE

Storing the outboard in a tilted position can damage the outboard. Water trapped in the cooling passages or rain water collected in the propeller exhaust outlet in the gearcase can freeze. Store the outboard in the full down position.

Battery Storage

- Follow the battery manufacturer's instructions for storage and recharging.
- Remove the battery from the boat and check water level. Recharge if necessary.
- Store the battery in a cool, dry place.
- Periodically check the water level and recharge the battery during storage.

TROUBLESHOOTING

Starter Motor Will Not Crank the Engine

POSSIBLE CAUSES

- Blown 20 amp fuse in the starting circuit. Refer to **Maintenance**.
- Outboard is not shifted to neutral position.
- Weak battery or battery connections are loose or corroded.
- Ignition key switch failure.
- Wiring or electrical connection faulty.
- Starter motor solenoid or slave solenoid failure.

Engine Will Not Start

POSSIBLE CAUSES

- Lanyard stop switch not in "RUN" position.
- Battery not fully charged.
- Incorrect starting procedure. Refer to **Operation** section.
- Old or contaminated fuel.
- Fuel is not reaching the engine.
 - Fuel tank is empty.
 - Fuel tank vent not open or restricted.
 - Fuel line is disconnected or kinked.
 - Primer bulb not squeezed.
 - Primer bulb check valve is faulty.
 - Fuel filter is obstructed. Refer to **Maintenance** section.
 - Fuel pump failure.
 - Fuel tank filter obstructed.
- Open 20 amp fuse. Check fuses, refer to **Maintenance** section.
- Threaded connection of an air hose is loose.
- Ignition system component failure.
- Spark plugs fouled or defective. Refer to **Maintenance** section.

Engine Runs Erratically

POSSIBLE CAUSES

- Spark plugs fouled or defective. Refer to **Maintenance** section.
- Incorrect setup and adjustments.
- Fuel is being restricted to the engine.
 - a. Engine fuel filter is obstructed. Refer to **Maintenance** section.
 - b. Fuel tank filter obstructed.
 - c. Stuck anti-siphon valve on built in fuel tank.
 - d. Fuel line is kinked or pinched.
 - e. Injector plugged.
- Threaded connection of an air hose is loose.
- Fuel pump failure.
- Ignition system component failure.

TROUBLESHOOTING

Performance Loss

POSSIBLE CAUSES

- Throttle not fully open.
- Damaged propeller or improper propeller size.
- Boat overloaded or load improperly distributed.
- Excessive water in bilge.
- Boat bottom is dirty or damaged.

Battery Will Not Hold Charge

POSSIBLE CAUSES

- Battery connections are loose or corroded.
- Low electrolyte level in battery.
- Worn out or inefficient battery.
- Excessive use of electrical accessories.
- Defective rectifier, alternator, or voltage regulator.
- Open circuit in the alternator output wire (fused link).

OWNER SERVICE ASSISTANCE

Local Repair Service

Always return your outboard to your local authorized dealer should the need for service arise. Only he has the factory trained mechanics, knowledge, special tools, equipment, and genuine parts and accessories to properly service your engine should the need occur. He knows your engine best.

Service Away From Home

If you are away from your local dealer and the need arises for service, contact the nearest authorized dealer. Refer to the Yellow Pages of the telephone directory. If, for any reason, you cannot obtain service, contact the nearest Mercury Marine Service Office.

Parts And Accessories Inquiries

All inquiries concerning genuine replacement parts and accessories should be directed to your local authorized dealer. The dealer has the necessary information to order parts and accessories for you. When inquiring on parts and accessories, the dealer requires the model and serial number to order the correct parts.

Service Assistance

Your satisfaction with your outboard product is very important to your dealer and to us. If you ever have a problem, question or concern about your outboard product, contact your dealer or any authorized Mercury Marine dealership. If additional assistance is required, take these steps.

1. Talk with the dealership's sales manager or service manager. If this has already been done, then contact the owner of the dealership.
2. Should you have a question, concern, or problem that cannot be resolved by your dealership, please contact Mercury Marine Service Office for assistance. Mercury Marine will work with you and your dealership to resolve all problems.

The following information will be needed by the service office:

- Your name and address
- Daytime telephone number
- Model and serial number of your outboard
- The name and address of your dealership
- Nature of problem

Mercury Marine Service Offices

For assistance, call, fax, or write. Please include your daytime telephone number with mail and fax correspondence.

United States		
Telephone	(920) 929-5040	Mercury Marine W6250 W. Pioneer Road P.O. Box 1939 Fond du Lac, WI 54936-1939
Fax	(920) 929-5893	
Website	www.mercurymarine.com	

Canada		
Telephone	(905) 567-6372	Mercury Marine Ltd. 2395 Meadowpine Blvd. Mississauga, Ontario L5N 7W6 Canada
Fax	(905) 567-8515	

OWNER SERVICE ASSISTANCE

Australia, Pacific		
Telephone	(61) (3) 9791-5822	Mercury Marine Australia 132-140 Frankston Road Dandenong, Victoria 3164 Australia
Fax	(61) (3) 9793-5880	

Europe, Middle East, Africa		
Telephone	(32) (87) 32 • 32 • 11	Marine Power - Europe, Inc. Parc Industriel de Petit-Rechain B-4800 Verviers, Belgium
Fax	(32) (87) 31 • 19 • 65	

Mexico, Central America, South America, Caribbean		
Telephone	(954) 744-3500	Mercury Marine 11650 Interchange Circle North Miramar, FL 33025 U.S.A.
Fax	(954) 744-3535	

Japan		
Telephone	81-053-423-2500	Mercury Marine - Japan Anshin-cho 283-1 Hamamatsu Shizuoka-ken, Japan 435-0005 Japan
Fax	81-053-423-2510	

Asia, Singapore		
Telephone	5466160	Mercury Marine Singapore 72 Loyang Way Singapore, 508762
Fax	5467789	

OUTBOARD INSTALLATION

Important Information

BEFORE STARTING THE ENGINE

NOTICE

Lack of oil pressure in the system can cause severe internal engine damage during start-up. Prime the oil injection pump on new or rebuilt engines or after performing maintenance on the oiling system.

Refer to **Priming the Oil Injection Pump** for instructions.

FUEL REQUIREMENTS

Do not use pre-mixed gas and oil in this engine. The engine automatically receives extra oil during engine break-in. Use a fresh supply of the recommended gasoline during engine break-in and after engine break-in.

OIL RECOMMENDATION

Recommended Oil	OptiMax Oil or Premium Plus 2-Cycle TC-W3 Outboard Oil
-----------------	--

OptiMax Oil or Premium Plus TC-W3 is a higher grade oil that provides increased lubrication and extra resistance to carbon buildup when used with good or varying grades of gasoline.

IMPORTANT: Oil must be NMMA certified TC-W3 2-Cycle oil.

Periodically consult with your dealer to get the latest gasoline and oil recommendations. If Mercury Precision or Quicksilver 2-Cycle Outboard Oil is not available, substitute another brand of 2-Cycle outboard oil that is NMMA Certified TC-W3. The use of an inferior 2-Cycle outboard oil can reduce engine durability. Damage from use of inferior oil may not be covered under the limited warranty.

Avoiding Fuel Flow Restriction

IMPORTANT: Adding components to the fuel supply system (filters, valves, fittings, etc.) may restrict the fuel flow. This may cause engine stalling at low speed, and/or a lean fuel condition at high RPM that could cause engine damage.

Electric Fuel Pump

The fuel pressure must not exceed 28 kPa (4 psi). If necessary, install a pressure regulator.

Boat Horsepower Capacity

WARNING

Exceeding the boat's maximum horsepower rating can cause serious injury or death. Overpowering the boat can affect boat control and flotation characteristics or break the transom. Do not install an engine that exceeds the boat's maximum power rating.

OUTBOARD INSTALLATION

Do not overpower or overload your boat. Most boats will carry a required capacity plate indicating the maximum acceptable power and load as determined by the manufacturer following certain federal guidelines. If in doubt, contact your dealer or the boat manufacturer.

U.S. COAST GUARD CAPACITY	
MAXIMUM HORSEPOWER	XXX
MAXIMUM PERSON CAPACITY (POUNDS)	XXX
MAXIMUM WEIGHT CAPACITY	XXX

26777

Start in Gear Protection

WARNING

Starting the engine with the drive in gear can cause serious injury or death. Never operate a boat that does not have a neutral-safety-protection device.

The remote control connected to the outboard must be equipped with a start in neutral only protection device. This prevents the engine from starting in gear.

Selecting Accessories For Your Outboard

Genuine Mercury Precision or Quicksilver Accessories have been specifically designed and tested for this outboard.

Some accessories not manufactured or sold by Mercury Marine are not designed to be safely used with this outboard or outboard operating system. Acquire and read the installation, operation, and maintenance manuals for all selected accessories.

Fuel Tanks

PORTABLE FUEL TANK

Select a suitable location in the boat within the engine fuel line length limitations and secure the tank in place.

PERMANENT FUEL TANK

Permanent fuel tanks should be installed in accordance with industry and federal safety standards, which include recommendations applicable to grounding, anti-siphon protection, ventilation, etc.

OUTBOARD INSTALLATION

Installation Specifications

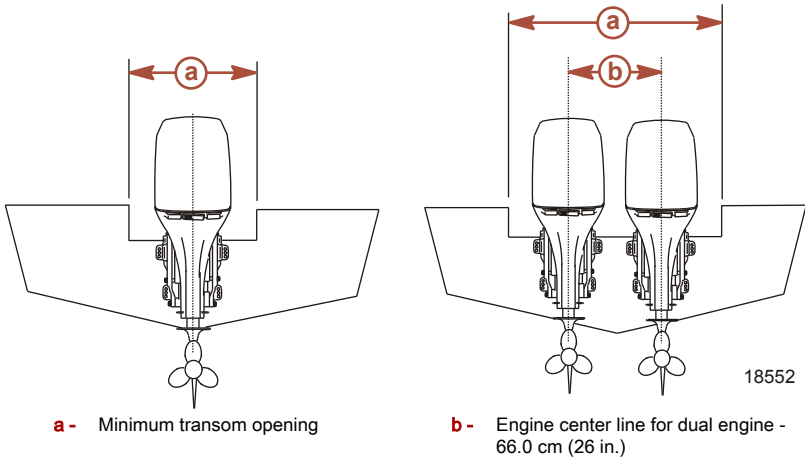

Minimum Transom Opening	
Single engine	84.8 cm (33-3/8 in.)
Dual engine	151.8 cm (59-3/4 in.)

Lifting the Outboard

WARNING

Improperly supporting an engine during lifting can result in the engine falling, causing serious injury or death. Before lifting the engine, verify that the lifting ring is threaded into the flywheel for a minimum of five turns and that the hoist has the correct lifting capacity for the engine weight.

To lift the outboard:

1. Remove the cowl from the outboard.
2. Thread the lifting eye into the flywheel for a minimum of five turns.

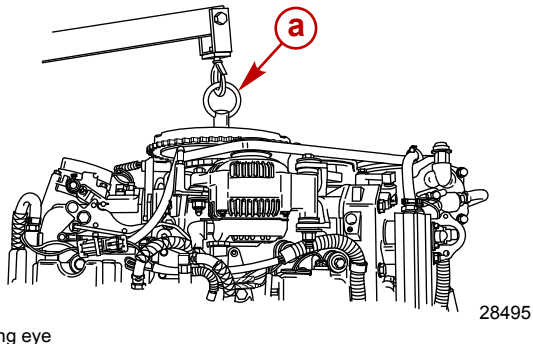

3. Connect a hoist to the lifting eye.

OUTBOARD INSTALLATION

- Lift the outboard and place it on the boat transom.

Lifting Eye	91-90455--1
	Threads into the flywheel to remove the powerhead assembly from the driveshaft housing, or to lift entire engine for removal/installation.

Steering Cable - Starboard Side Routed Cable

- Lubricate O-ring seal and entire cable end.

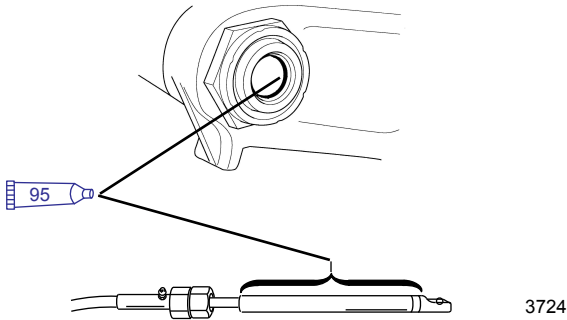

Tube Ref No.	Description	Where Used	Part No.
	2-4-C Marine Lubricant with Teflon	O-ring seal and entire cable end	92-802859Q1

- Insert steering cable into tilt tube.

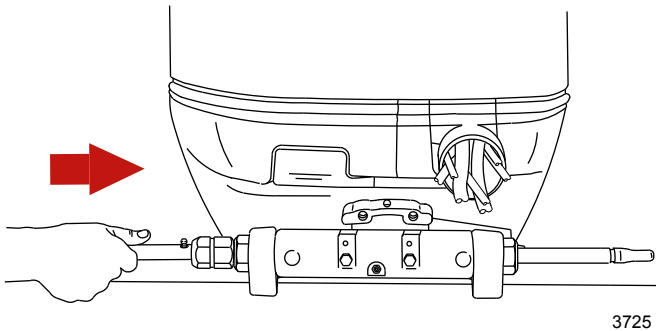

OUTBOARD INSTALLATION

3. Torque nut to specification.

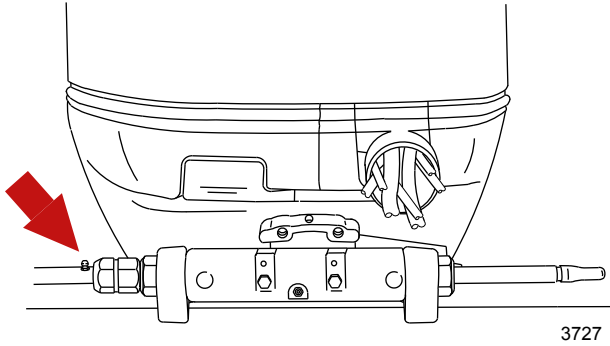

Description	Nm	lb. in.	lb. ft.
Nut	47.5		35

Steering Link Rod Fasteners

IMPORTANT: The steering link rod that connects the steering cables to the engine must be fastened using special washer head bolt (P/N 10-849838) and self-locking nylon insert locknuts (P/N 11-826709113). Never replace locknuts with common nuts (non-locking) as they will work loose/vibrate off freeing link rod to disengage.

WARNING

Improper fasteners or improper installation procedures can result in loosening or disengagement of the steering link rod. This can cause a sudden, unexpected loss of boat control, resulting serious injury or death due to occupants being thrown within or out of the boat. Always use required components and follow instructions and torque procedures.

OUTBOARD INSTALLATION

⚠ WARNING

Worn, loose, or seized steering components can lead to loss of boat control. Inspect all steering attachment components for wear, lubricate all attachment hardware, and check all fasteners for proper tightness in accordance with the inspection and maintenance schedule.

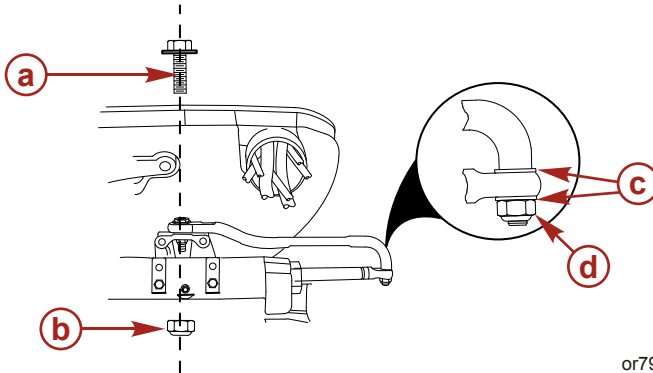

or79

- a** - Special washer head bolt (P/N 10-849838)
- b** - Nylon Locknut - used on head bolt (P/N 11-826709113)
- c** - Flat washer (2)
- d** - Nylon Locknut - used on cable coupler (P/N 11-826709113)

1. Assemble steering link rod to steering cable coupler with two flat washers "c" and a self-locking nylon insert locknut "d." Tighten the locknut until it seats, then loosen ¼ turn.
2. Assemble the steering link rod to the engine with the special washer head bolt "a" and self locking nylon insert locknut "b."
3. Torque the head bolt, then the locknut to specifications.

Description	Nm	lb. in.	lb. ft.
Cable Coupler Nylon Locknut "d"	Tighten locknut until it seats, then loosen ¼ turn.		
Head Bolt Nylon Locknut "b"	27		20
Special washer head bolt	27		20

OUTBOARD INSTALLATION

Determining Recommended Outboard Mounting Height

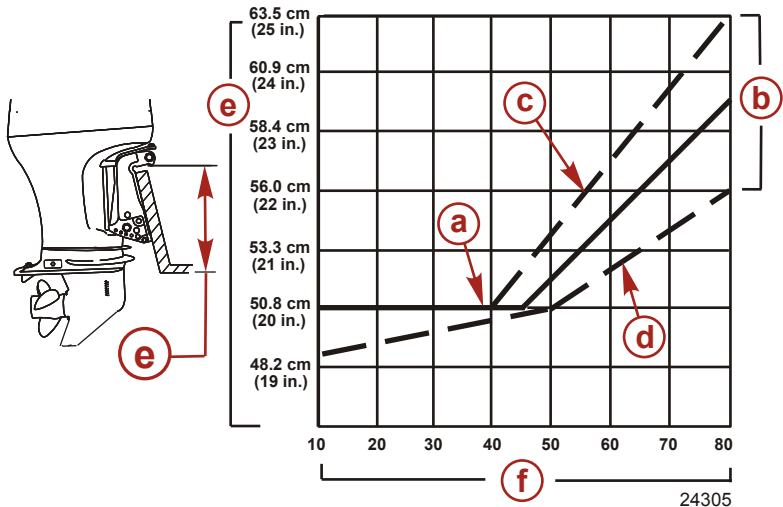

- a** - The solid line is recommended to determine the outboard mounting height.
- b** - The broken lines represent the extremes of known successful outboard mounting height dimensions.
- c** - This line may be preferred to determine outboard mounting height dimension, if maximum speed is the only objective.
- d** - This line may be preferred to determine outboard mounting height dimension for dual outboard installation.
- e** - Outboard mounting height (height of outboard mounting brackets from bottom of boat transom). For heights over 56.0 cm (22 in.), a propeller that is designed for surfacing operation is usually preferred.
- f** - Maximum boat speed (MPH) anticipated

Drilling Outboard Mounting Holes

IMPORTANT: Before drilling any mounting holes, carefully read Determining Recommended Outboard Mounting Height and install outboard to the nearest recommended mounting height.

OUTBOARD INSTALLATION

1. Mark four mounting holes on the transom using the transom drilling fixture.

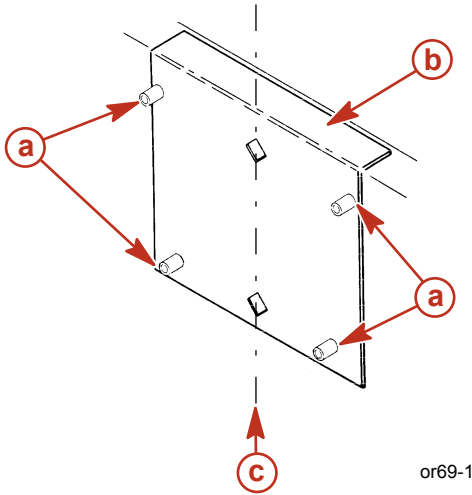

or69-1

- a** - Drill guide holes
- b** - Transom drilling fixture

c - Transom centerline

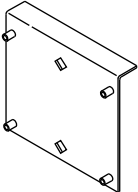
Transom Drilling Fixture	91-98234A2
 <p>5489</p>	<p>Aids in engine installation by acting as a template for engine mounting holes.</p>

2. Drill four 13.5 mm (17/32 in.) mounting holes.

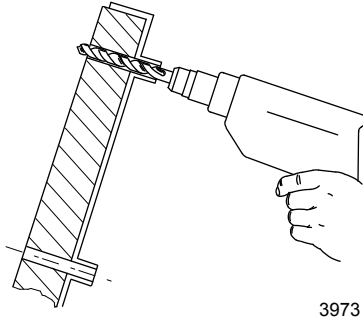

3973

OUTBOARD INSTALLATION

Fastening the Outboard to the Transom

MOUNTING BOLTS

Outboard Transom Mounting Hardware - Supplied with Outboard		
Part Number	Part Name	Description
10-67755-1	Transom bolt	1/2-20 x 4.50 in. long (2.25 in. thread)
11-826711-17	Nylon insert locknut	1/2-20
12-28421	Washer - Inner	0.516 in. ID x 1.50 in. OD
12-54012	Washer - Outer	0.53 in. ID x 0.87 in. OD

Available Transom Mounting Bolts		
Part Number	Part Name	Description
10-67755005	Transom bolt	1/2-20 x 2.50 in. long (1.25 in. thread)
10-67755006	Transom bolt	1/2-20 x 3.50 in. long (1.25 in. thread)
10-814259	Transom bolt	1/2-20 x 4.00 in. long (2.25 in. thread)
10-67755-1	Transom bolt	1/2-20 x 4.50 in. long (2.25 in. thread)
10-67755-003	Transom bolt	1/2-20 x 5.50 in. long (3.25 in. thread)
10-67755-2	Transom bolt	1/2-20 x 6.50 in. long (2.75 in. thread)

CHECKING BOAT TRANSOM CONSTRUCTION

IMPORTANT: Determine the strength of the boat transom. The outboard mounting locknuts and bolts should be able to hold 75 Nm (55 lb. ft.) of torque without the boat transom yielding or cracking. If the boat transom yields or cracks under this torque, the construction of the transom may not be adequate. The boat transom must be strengthened or the load carrying area increased.

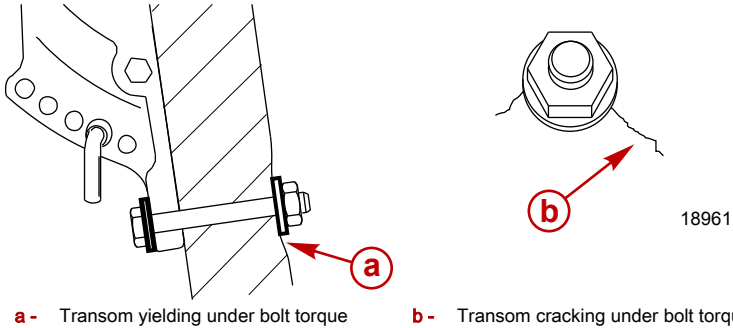

When first determining transom strength, use a dial torque wrench. If the bolt or nut continues to turn without the torque reading on the dial increasing, it is an indication that the transom is yielding. The load area can be increased by using a larger washer or a transom reinforcement plate.

OUTBOARD INSTALLATION

NOTE: The inside holes on the transom reinforcement plate are for the lower transom bolts and the outside holes are for the upper transom bolts.

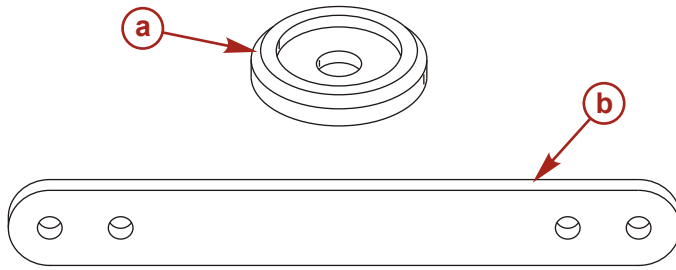

20860

a - Large transom washer

b - Transom reinforcement plate

Description	Part Number
Large transom washer	67-896392
Transom reinforcement plate	67-896305

1. Apply marine sealer to shanks of bolts, not the threads.
2. Fasten the outboard with the correct mounting hardware. Tighten locknuts to the specified torque.

NOTE: For more accurate torque, whenever possible turn/tighten the mounting locknuts rather than turning the mounting bolts.

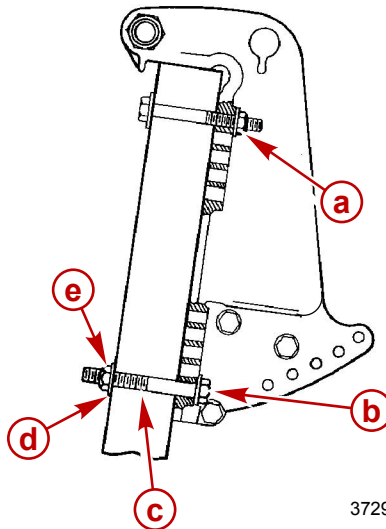

3729

a - Flat washer (4)

b - 1/2 in. diameter bolt (4)

c - Shank of bolt

d - Flat washer (4)

e - Locknut (4)

Description	Nm	lb. in.	lb. ft.
Outboard mounting locknuts and bolts	75		55

OUTBOARD INSTALLATION

Electrical, Hoses, and Control Cables

FRONT CLAMP DISASSEMBLY

Remove screws and open the front clamp assembly.

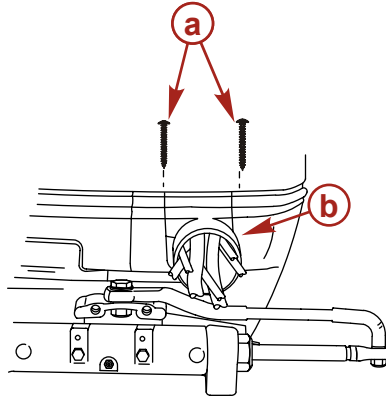

a - Screw (2)

b - Front clamp

7644

REMOTE WIRING HARNESS

Route the remote 14 pin boat harness through the front clamp. Connect remote harness to the 14 pin connector on the engine harness.

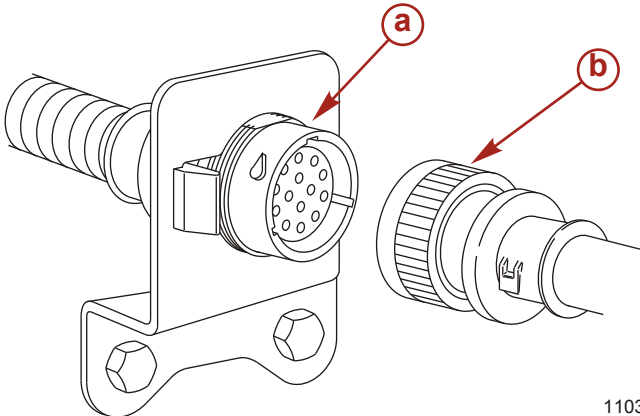

a - 14 pin connector

b - Remote 14 pin boat harness

11033

BATTERY INFORMATION

⚠ WARNING

Failure to properly secure the battery leads can result in a loss of power to the Digital Throttle and Shift (DTS) system, leading to serious injury or death due to loss of boat control. Secure the battery leads to the battery posts with hex nuts to avoid loose connections.

OUTBOARD INSTALLATION

- Do not use deep cycle batteries. Engines must use a marine starting battery with 1000 MCA, 800 CCA or 180 Ah.
- When connecting engine battery, hex nuts must be used to secure battery leads to battery posts. Torque nuts to specification.

Description	Nm	lb. in.	lb. ft.
Hex nuts	13.5	120	

IMPORTANT: Battery cable size and length is critical. Refer to engine installation manual for size requirements.

Decal needs to be placed on or near battery box for future service reference. One 5/16 in. and one 3/8 in. hex nut are supplied per battery for wing nut replacement. Metric hex nuts are not supplied.

NOTICE - DTS & Optimax Engines

DO NOT USE DEEP CYCLE BATTERIES!
DTS (Digital Throttle and Shift) applications and Optimax engines must use a marine starting battery with 1000 MCA, 800 CCA, or 180 Ah. rating.

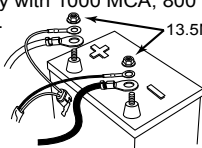

13.5Nm (120 lbs. in.)



DO NOT USE WING NUTS.

IMPORTANT:
Battery cable size and length is critical. Refer to engine installation manual for size requirements.
37-895387

Place decal on or near battery box for future service reference. 5/16" and 3/8" hex nuts supplied for wing nut replacement. Metric hex nuts not supplied.

3486

BATTERY CABLE CONNECTIONS

Single Outboard

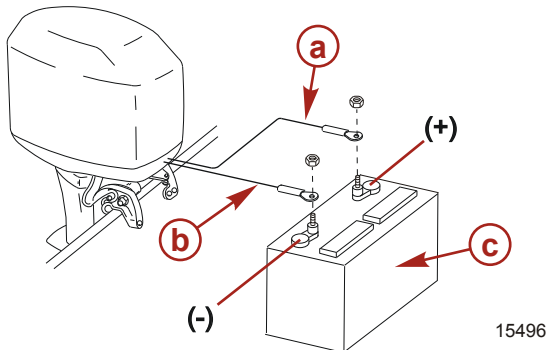

- a** - Red sleeve - positive (+)
- b** - Black sleeve - negative (-)
- c** - Cranking battery

OUTBOARD INSTALLATION

Dual Outboards

Connect a common ground cable (wire size same as engine battery cables) between negative (-) terminals on starting batteries.

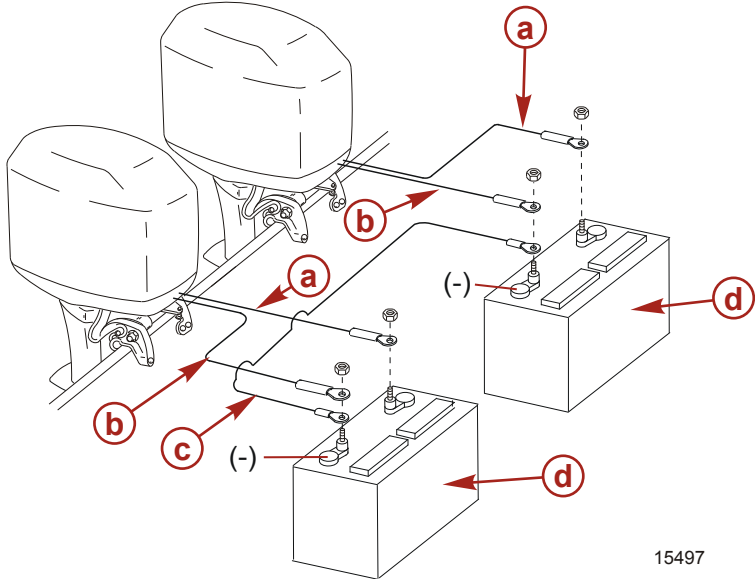

a - Red sleeve - positive (+)
b - Black sleeve - negative (-)

c - Ground cable
d - Cranking battery

15497

FUEL HOSE AND OIL HOSE CONNECTIONS

Fuel Hose Connection

Fuel Hose Size - Minimum fuel line inside diameter (I.D.) is 8mm (5/16 in.), with separate fuel line/fuel tank pickup for each engine.

1. Fasten remote fuel hose to fitting with hose clamp.

OUTBOARD INSTALLATION

- Connect the remote oil hoses to the engine hose connections. Fasten hose connections with cable ties.

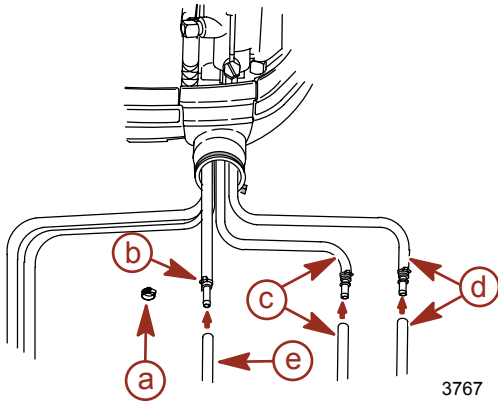

- | | |
|---|--------------------------------------|
| a - Hose clamp | d - Oil hose with blue stripe |
| b - Cable tie | e - Remote fuel hose |
| c - Oil hose without blue stripe | |

SPEEDOMETER AND WATER PRESSURE TUBING CONNECTIONS

NOTE: This applies to models without SmartCraft gauges.

This outboard has a speedometer water pick-up located in the leading edge of the gearcase. If you want to use this water pickup for the speedometer, disconnect the water pickup tubing from the speedometer sensor and route tubing out of the cowl. Install coupler (provided with outboard) on end of tubing.

Make the water pressure gauge hose connection to this tubing as follows:

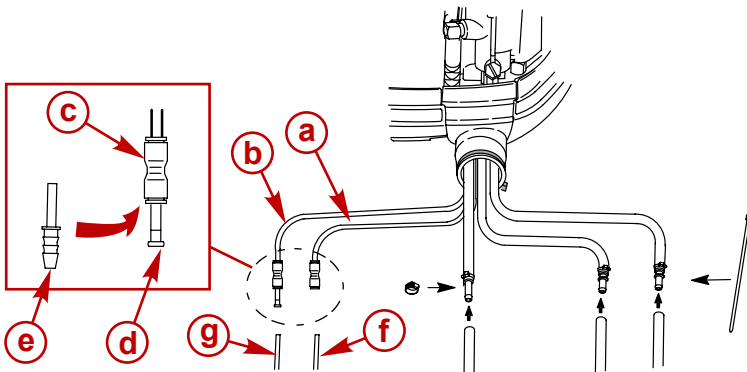

- | | |
|---|--------------------------------|
| a - Speedometer water pick-up tube | e - Barb hose fitting |
| b - Water pressure tube | f - Speedometer hose |
| c - Coupler | g - Water pressure tube |
| d - Plug | |

OUTBOARD INSTALLATION

Shift and Throttle Cable

COUNTER ROTATION OUTBOARDS

Counter rotating (left hand) gearcases can be identified by a "L" stamped into the end of the propeller shaft.

The Quicksilver Dual Engine Console Mount Control is required to shift the counter rotation outboard. The installation instructions shipped with the control explain the procedure required to connect this control to a counter rotation outboard.

IMPORTANT: If the counter rotation outboard is rigged similar to a standard rotation outboard OR if a standard rotation outboard is rigged similar to a counter rotation outboard, the reverse gear and bearing in the gearcase must function as forward gear. The reverse gear/bearing is not designed to carry the sustained loads that are generated when running under constant high RPM and thrust conditions.

On counter rotation outboards, the shift linkage moves in the opposite direction compared to a standard rotation outboard.

Forward Gear ← → Reverse Gear

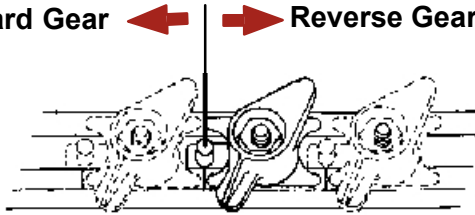

7724

Reverse Gear ← → Forward Gear

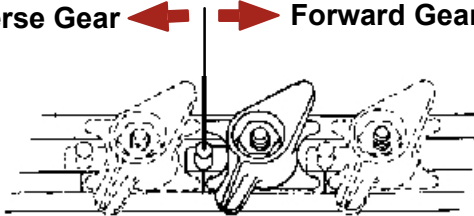

7726

Standard Rotation

Counter Rotation

INSTALLING THE SHIFT CABLE

IMPORTANT: The shift cable is the first cable to move when the remote control handle is moved out of neutral, so install/connect it to the engine first.

Locating the Center Point of the Shift Cable

IMPORTANT: Locate the center point of the slack or lost motion that exists in the shift cable for proper adjustment of the shift cable.

1. Mark the forward position as follows:
 - a. Move the remote control handle from neutral into forward and advance the handle to the full speed position. Ensure that the throttle control lever is touching the throttle control lever stop screw.
 - b. Slowly return the handle back to the neutral detent position.

OUTBOARD INSTALLATION

- c. Place a mark on the shift cable against the cable end guide.

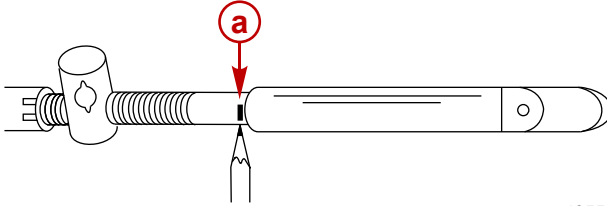

- a -** Forward position mark

2. Mark the reverse position as follows:

- a. Move the remote control handle into reverse and advance the handle to the full speed position. Ensure that the throttle control lever is touching the throttle control lever stop screw.
- b. Slowly return the handle back to the neutral detent position.
- c. Place a mark on the shift cable against the cable end guide.

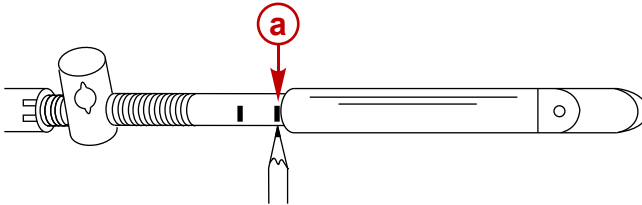

- a -** Reverse position mark

3. Mark the center on the shift cable midway between the forward and reverse marks.

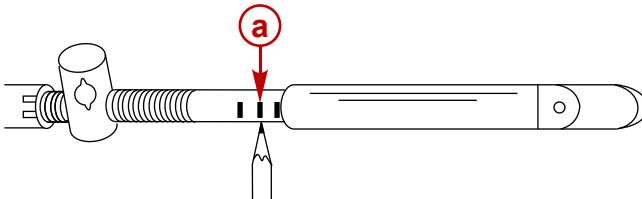

- a -** Center mark

4. Align the cable end guide against this center mark when installing the cable to the engine.
5. Position the remote control and outboard into neutral position.
6. Slide the shift cable retainer forward until resistance is felt, then slide the cable anchor toward the rear until resistance is felt.

OUTBOARD INSTALLATION

- Center the anchor pin between these resistance points.

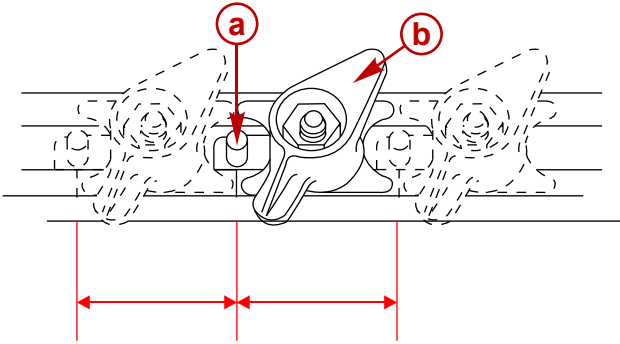

4363

a - Anchor pin

b - Shift cable retainer

Adjusting the Shift Cable

To adjust the shift cable:

- Align the shift cable end guide with the center mark as instructed in **Locating the Center Point of the Shift Cable**.

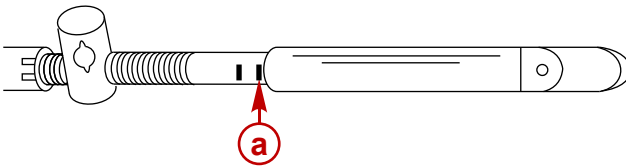

4362

a - Center mark

- Place the shift cable end guide on the anchor pin and adjust the cable barrel so that it slips freely into the barrel holder.
- Secure the shift cable with the shift cable retainer.

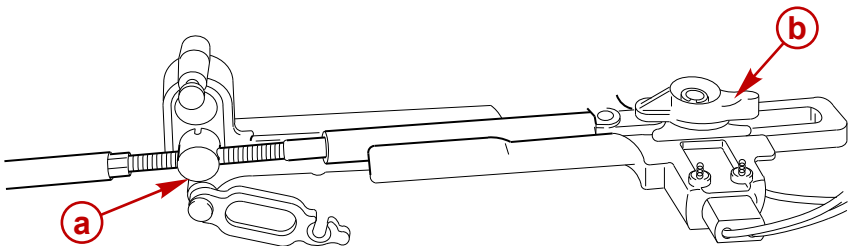

4364

a - Cable barrel

b - Shift cable retainer

- Check the shift cable adjustments as follows:
 - Shift the remote control to forward while turning the propeller shaft. If the propeller shaft does not lock in gear, adjust the cable barrel closer to the cable end guide.

OUTBOARD INSTALLATION

- b. Shift the remote control into neutral. If the propeller shaft does not turn freely without drag, adjust the barrel away from the cable end guide. Repeat steps a and b.
 - c. Shift the remote control into reverse while turning the propeller shaft. If the propeller shaft does not lock solidly in gear, adjust the barrel away from the cable end guide. Repeat steps a through c.
 - d. Return the remote control handle to neutral. If the propeller shaft does not turn freely without drag, adjust the barrel closer to the cable end guide. Repeat steps a through d.
5. Return the safety stop switch to the "RUN" position.

THROTTLE CABLE INSTALLATION

1. Position remote control into neutral.

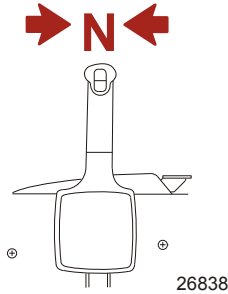

2. Attach throttle cable to the throttle lever. Secure with washer and locknut.

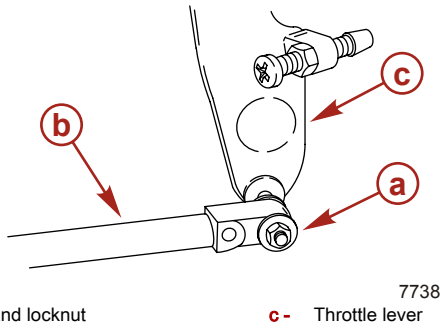

- a**- Washer and locknut
b- Throttle cable

- c**- Throttle lever

OUTBOARD INSTALLATION

- Adjust the throttle cable barrel so that the installed throttle cable will hold the idle stop screw against the stop.

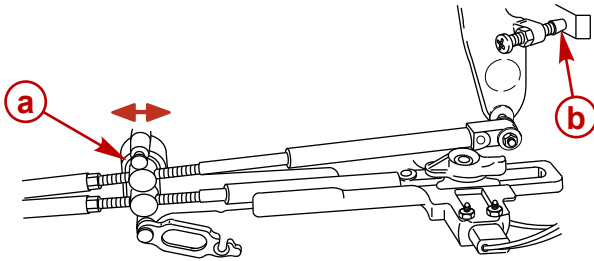

4366

a - Throttle cable barrel

b - Idle stop screw

- Check throttle cable adjustment as follows:
 - Shift outboard into gear a few times to activate the throttle linkage. Make sure to rotate the propeller shaft while shifting into reverse.
 - Return remote control to neutral. Place a thin piece of paper between idle adjustment screw and idle stop. Adjustment is correct when the paper can be removed without tearing, but has some drag on it. Readjust cable barrel if necessary.

IMPORTANT: The idle stop screw must be touching the stop.

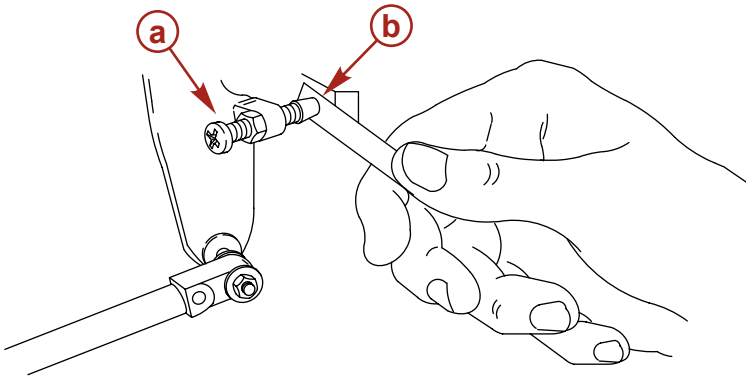

7740

a - Idle stop screw

b - Idle stop

- Lock the barrel holder in place with the cable latch.

Front Clamp Reassembly

IMPORTANT: Sufficient slack must exist in engine wiring harness, battery cables, fuel hose, and oil hoses routed between clamp and engine attachment point, to relieve stress and prevent hoses from being kinked or pinched.

OUTBOARD INSTALLATION

1. Place the neoprene wrap over the wiring, hoses, and control cables.

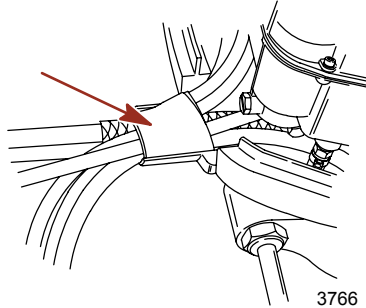

2. Fasten clamp together with two screws.

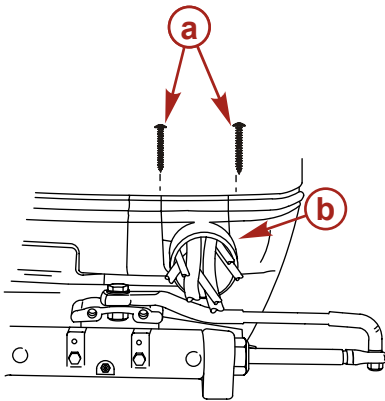

a - Screw (2)

b - Front clamp

Filling the Fuel System

When starting an engine for the first time, or starting an engine that ran out of fuel or was drained of fuel, fill and prime the fuel system.

To fill and prime the fuel system:

1. Squeeze the fuel line primer bulb until it feels firm.
2. Turn the key switch to the "ON" position for three seconds. This operates the electric fuel pump.
3. Turn the key switch back to the "OFF" position and squeeze the primer bulb again until it feels firm.
4. Turn the key switch to the "ON" position again for three seconds.
5. Continue this procedure until the fuel line primer bulb stays firm.

OUTBOARD INSTALLATION

Oil Injection Set-up

FILLING OIL SYSTEM

1. Fill remote oil tank with the recommended oil listed in the Operation and Maintenance Manual. Tighten fill cap.

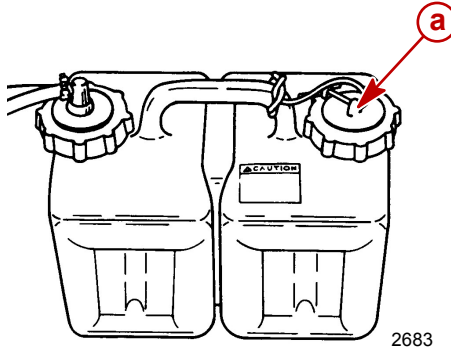

a - Fill cap

2. Remove cap and fill engine oil tank with oil. Reinstall the fill cap.

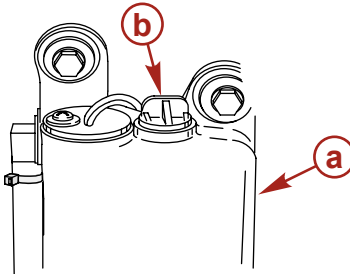

a - Engine oil tank

b - Fill cap

OUTBOARD INSTALLATION

PRIMING THE OIL INJECTION PUMP

Before starting engine for the first time, prime the oil injection pump. Priming will remove any air that may be in the pump, oil supply hose, or internal passages.

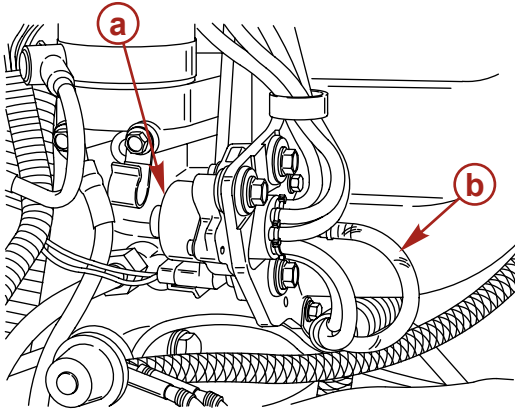

a - Oil injection pump

b - Oil supply hose

7747

IMPORTANT: Fill the engine fuel system with fuel before priming the oil injection pump. Otherwise, the fuel pump will run without fuel during the priming process and may be damaged.

Prime the oil injection pump as follows:

1. Fill the engine fuel system with fuel. Connect fuel hose and squeeze primer bulb until it feels firm.

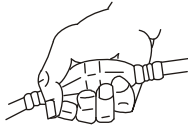

19779

2. Turn the ignition key switch to the "ON" position.

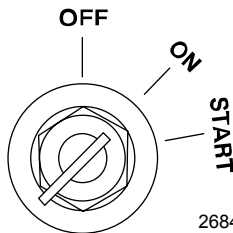

26846

3. Within the first 10 seconds after the key switch has been turned on, move the remote control handle from neutral into forward gear 3 to 5 times. This will automatically start the priming process.

NOTE: It may take a few minutes for the pump to complete the priming process.

PURGING AIR FROM THE ENGINE OIL TANK

1. Loosen the fill cap on the engine oil tank.
2. Start the engine.
3. Operate the engine until all the air has vented out and oil starts to flow out of the tank.
4. Re-tighten fill cap.

OUTBOARD INSTALLATION

Propeller Installation

WARNING

Rotating propellers can cause serious injury or death. Never operate the boat out of the water with a propeller installed. Before installing or removing a propeller, place the drive unit in neutral and engage the lanyard stop switch to prevent the engine from starting.

1. Flo-Torq I Drive Hub Propellers - Install forward thrust hub, propeller, continuity washer, rear thrust hub, propeller nut retainer, and propeller nut onto the shaft.

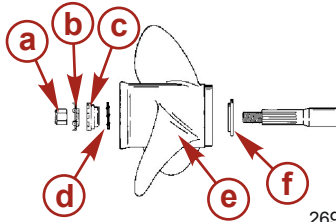

- | | |
|-----------------------------------|-------------------------------|
| a - Propeller nut | d - Continuity washer |
| b - Propeller nut retainer | e - Propeller |
| c - Rear thrust hub | f - Forward thrust hub |

2. Flo-Torq II Drive Hub Propellers - Install forward thrust hub, replaceable drive sleeve, propeller, thrust hub, propeller nut retainer and propeller nut onto the shaft.

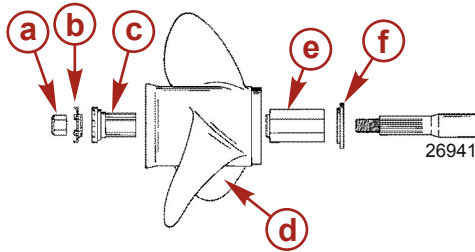

- | | |
|-----------------------------------|-------------------------------------|
| a - Propeller nut | d - Propeller |
| b - Propeller nut retainer | e - Replaceable drive sleeve |
| c - Rear thrust hub | f - Forward thrust hub |

3. Place a block of wood between gearcase and propeller and torque to specifications.

Description	Nm	lb. in.	lb. ft.
Propeller nut	75		55

OUTBOARD INSTALLATION

- Secure propeller nut by bending three of the tabs into the thrust hub grooves.

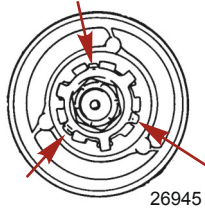

Trim In Pin

⚠ WARNING

Operating the boat at high speeds with the outboard trimmed too far under can create excessive bow steer, resulting in the operator losing control of the boat. Install the trim limit pin in a position that prevents excessive trim under and operate the boat in a safe manner.

Some boats, particularly some bass boats, are built with a greater than normal transom angle, which will allow the outboard to be trimmed further in or under. This greater trim under capability is desirable to improve acceleration, reduce the angle and time spent in a bow high boat during planing off, and in some cases, may be necessary to plane off a boat with aft live wells, given the variety of available propellers and height range of engine installations.

However, once on plane, the engine should be trimmed to a more intermediate position to avoid a bow-down planing condition called plowing. Plowing can cause bow steering or over steering and inefficiently consumes horsepower.

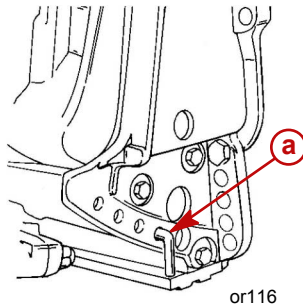

a - Tilt pin (not included with engine)

Stainless Steel Tilt Pin	17-49930A 1
<p>2749</p>	Limits the down trim angle of the power trim equipped engines, or aids in determining the trim out angle on non-power trim engines.

The owner may decide to limit the trim in. This can be accomplished by purchasing a stainless steel tilt pin from your dealer and insert it in whatever adjustment hole in the transom brackets is desired. A non-stainless steel shipping bolt should not be used in this application other than on a temporary basis.