

# Thank You . . .

for your purchase of one of the finest outboards available. You have made a sound investment in boating pleasure. Your outboard has been manufactured by Mercury Racing, a unit of Mercury Marine, the world leader in marine technology and outboard manufacturing since 1939. These years of experience have been committed to the goal of producing the finest quality products. This has led to Mercury Racing's reputation for strict quality control, excellence, durability, lasting performance and being the best at providing after-the-sale support.

Please read this manual carefully before operating your outboard. This manual has been prepared to assist you in the operation, safe use and care of your outboard.

All of us at Mercury Racing took pride in building your outboard and wish you many years of happy and safe boating.

Again, thank you for your confidence in Mercury Marine.



Mercury Racing  
N7480 County Road "UU"  
Fond du Lac, WI 54935-9585



# TABLE OF CONTENTS

## General Information

Boater’s Responsibilities .....	4
Before Operating Your Outboard .....	4
Boat Horsepower Capacity .....	5
High-Speed And High-Performance Boat Operation .....	5
Lanyard Stop Switch .....	6
Protecting People In The Water .....	8
Carbon Monoxide Risk .....	9
Wave And Wake Jumping .....	11
Impact With Underwater Hazards .....	12
Selecting Accessories For Your Outboard .....	14
Safe Boating Suggestions .....	14
Recording Serial Number .....	16
Specifications .....	17
Component Identification .....	18
Propeller Selection .....	19

## Transporting

Trailerling Boat/Outboard .....	20
---------------------------------	----

## Fuel & Oil

Gasoline Recommendations .....	21
Oil Recommendation .....	22
Filling Fuel Tank .....	23
Filling Remote Oil Tank .....	24
Filling Engine Mounted Oil Reservoir Tank .....	24

# TABLE OF CONTENTS

## Features & Controls

Remote Control Features .....	25
Warning Horn System .....	26
Power Trim And Tilt .....	30
Power Trim Operation .....	31
Tilting Operation .....	33
Manual Tilting .....	35

## Operation

Engine Break-in .....	37
Pre-Starting Check List .....	39
Operating In Freezing Temperatures .....	40
Operating In Salt Water Or Polluted Water .....	40
Operating At High Elevations .....	40
Setting Trim Angle While Running Engine at Idle Speed ...	41
Operating in Shallow Water .....	41
Starting The Engine .....	42
Gear Shifting .....	44
Stopping The Engine .....	44
Emergency Starting .....	45

## Maintenance

Outboard Care .....	47
Submerged Outboard .....	47
Selecting Replacement Parts For Your Outboard .....	47
EPA Emissions Regulations .....	47
Inspection And Maintenance Schedule .....	48
Flushing the Cooling System .....	50
Top Cowl Removal and Installation .....	52
Flywheel Cover Removal and Installation .....	53
Fuel System .....	53

(continued on next page)

# TABLE OF CONTENTS

## Maintenance (con't.)

Steering Link Rod Fasteners .....	55
Fuse Replacement .....	56
Corrosion Control Anodes .....	56
Propeller Replacement .....	57
Spark Plug Inspection .....	59
Battery Inspection .....	59
Alternator Drive Belt Tension Adjustment .....	60
Lubrication Points .....	61
Checking Power Trim Fluid .....	63
Gear Case Lubricant .....	65

## Storage

Storage Preparation .....	67
---------------------------	----

## Troubleshooting

Troubleshooting .....	70
-----------------------	----

## Engine Wiring Diagram

Engine Wiring Diagram .....	74
-----------------------------	----

## Maintenance Log

Maintenance Log .....	76
-----------------------	----

The description and specifications contained herein were in effect at the time this manual was approved for printing. Mercury Racing, whose policy is one of continued improvement, reserves the right to discontinue models at any time, to change specifications, designs, methods, or procedures without notice and without incurring obligation.

Mercury Marine, Fond du Lac, Wisconsin U.S.A.      Litho in U.S.A.

© 1999, Mercury Marine

The following are registered trademarks of Brunswick Corporation: AutoBlend, Force, Jet-Prop, Mariner, Merc, Mercathode, MerCruiser, Mercury, Mercury Marine, Mercury Racing, Quicksilver, Ride-Guide and Thruster

# GENERAL INFORMATION

oba1

## Boater's Responsibilities

The boat driver is responsible for correct and safe operation of the boat and safety of its occupants and general public. It is strongly recommended that each operator (driver) read and understand this entire manual before operating the outboard.

Be sure that at least one additional person on board is instructed in the basics of starting and operating the outboard and boat handling in case the driver is unable to operate the boat.

obb1

## Before Operating Your Outboard

Read this manual carefully. Safety and operating information that is practiced along with using good common sense can help prevent personal injury and product damage. If you have any questions, contact your dealer.

This manual as well as safety labels posted on the outboard use safety alerts to draw your attention to special safety instructions that must be followed.

### **WARNING**

**WARNING – Hazards or unsafe practices which COULD result in severe personal injury or death.**

### **CAUTION**

**CAUTION – Hazards or unsafe practices which could result in minor injury or product or property damage.**

# GENERAL INFORMATION

<b>U.S. COAST GUARD CAPACITY</b>	
<b>MAXIMUM HORSEPOWER</b>	<b>XXX</b>
<b>MAXIMUM PERSON CAPACITY (POUNDS)</b>	<b>XXX</b>
<b>MAXIMUM WEIGHT CAPACITY</b>	<b>XXX</b>

**1**

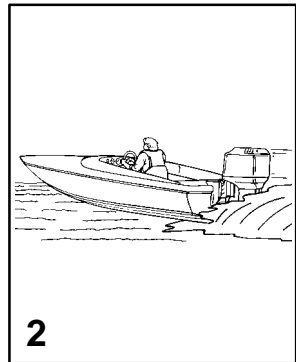

## Boat Horsepower Capacity

- 1 Do not overpower or overload your boat. Most boats will carry a required capacity plate indicating the maximum acceptable power and load as determined by the manufacturer following certain federal guidelines. If in doubt, contact your dealer or the boat manufacturer.

**⚠ WARNING**

**Overpowering a Boat Can Cause:**

- **Serious injury, death, or boat damage.**
- **Loss of Boat Control.**
- **Flotation Characteristics of Boat to be Altered from Placing Too Much Weight on Transom.**
- **Boat to Break Apart, Particularly Around the Transom Area.**

## High-Speed And High-Performance Boat Operation

- 2 If you are not familiar with high-performance boat operation we recommend that you first request an orientation/demonstration ride with your dealer or an operator experienced with your boat/outboard combination. Refer to the “Guide to Hi-Performance Boat Operation” booklet (Part Number 90-849250) included in your literature packet.

# GENERAL INFORMATION

gob8

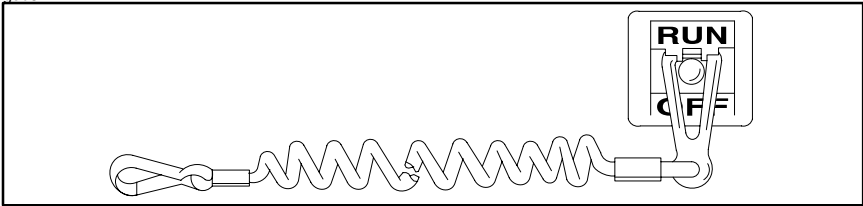

obg6

## Lanyard Stop Switch

### **⚠ WARNING**

**Should the operator fall out of the boat, the possibility of serious injury or death from being run over by the boat can be greatly reduced by stopping the engine immediately. Always properly connect both ends of the stop switch lanyard – to the stop switch and the operator.**

1. The purpose of a lanyard stop switch is to turn off the engine when the operator moves far enough away from the operator's position (as in accidental ejection from the operator's position) to activate the switch. A lanyard stop switch can be installed as an accessory – generally on the dashboard or side adjacent to the operator's position.
2. While activation of the lanyard stop switch will stop the engine immediately, a boat will continue to coast for some distance depending upon the velocity and degree of any turn at shut-down. However, the boat will not complete a full circle. While the boat is coasting, it can cause injury to anyone in the boat's path as seriously as the boat would when under power.



# GENERAL INFORMATION

## Lanyard Stop Switch (Continued)

### **WARNING**

**Avoid serious injury or death from deceleration forces resulting from in accidental stop switch activation. The boat operator should never leave the operator's station without first disconnecting the stop switch lanyard cord from themselves.**

Accidental or unintended activation of the Lanyard Stop Switch during normal operation is a possibility and could cause any, or all, of the following potentially hazardous situations:

1. Occupants could be thrown forward due to unexpected loss of forward motion – a particular concern for passengers in the front of the boat who could be ejected over the bow and possibly struck by the gear case or propeller.
2. Loss of power and directional control in heavy seas, strong current or high winds.
3. Loss of control when docking.

# GENERAL INFORMATION

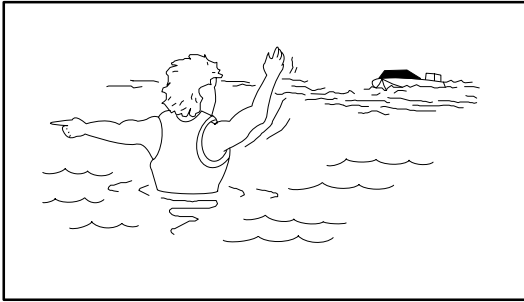

## Protecting People In The Water

### WHILE YOU ARE CRUISING

It is very difficult for a person in the water to take quick action to avoid a boat heading in their direction even at slow speed.

Always slow down and exercise extreme caution any time you are boating in an area where there might be people in the water.

Whenever a boat is moving (even coasting) even with the outboard in neutral position, there is sufficient force by the water to rotate the propeller. This neutral propeller rotation can cause serious injury.

### WHILE BOAT IS STATIONARY

Shift outboard into neutral and shut off the engine before allowing people to swim or be in the water near your boat.

## **WARNING**

**Stop your engine immediately whenever anyone in the water is near your boat. Serious injury to the person in the water is likely if contacted by a rotating propeller, a moving boat, a moving gear case, or any solid device rigidly attached to a moving boat or gear case.**

# GENERAL INFORMATION

gob4

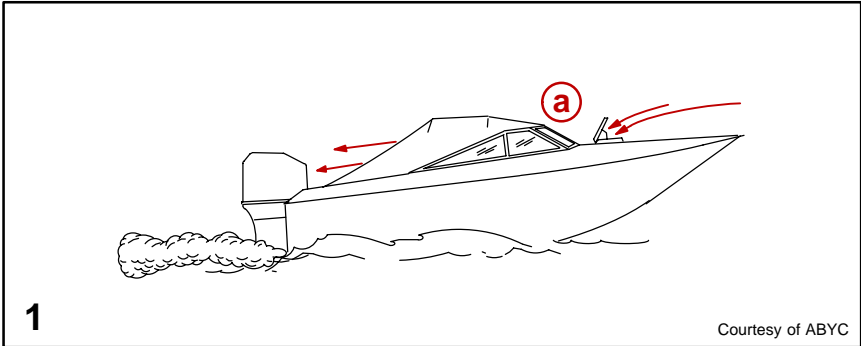

## Carbon Monoxide Risk

### **⚠ WARNING**

**Avoid the combination of a running engine and poor ventilation. Prolonged exposure to carbon monoxide in sufficient concentration can lead to unconsciousness, brain damage, or death.**

Carbon monoxide is a deadly gas that is odorless, colorless and tasteless and is present in the exhaust fumes of all internal combustion engines.

Early symptoms of carbon monoxide poisoning which should not be confused with seasickness or intoxication, include headache, dizziness, drowsiness, and nausea.

## SUFFICIENT FRESH AIR FLOW

### **1 Example of desired air flow through the boat;**

- a. Ventilate passenger area, open side curtains, or forward hatches to remove carbon monoxide fumes.

# GENERAL INFORMATION

gob39

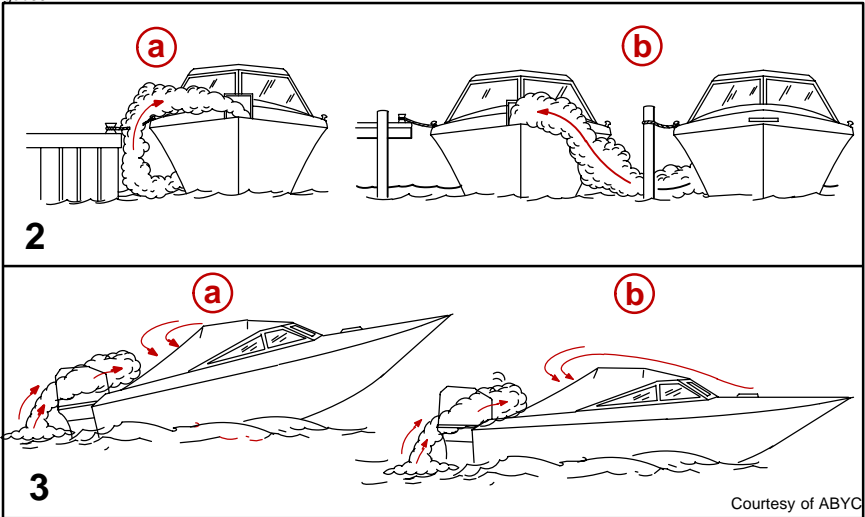

obi3

## Carbon Monoxide Risk (Continued)

### INSUFFICIENT FRESH AIR FLOW

Under certain conditions, enclosed or canvas enclosed cabins or cockpits with insufficient ventilation may draw in carbon monoxide. Install one or more carbon monoxide detectors in your boat.

Although rare, on a very calm day, swimmers and passengers in an open stationary boat with a running engine, or near a running engine may be exposed to a hazardous level of carbon monoxide.

### Insufficient Air Flow Could Occur If:

#### 2 While boat is stationary:

- a. Boat moored in a confined space with the engine running.
- b. Boat is moored close to another boat with its engine running.

#### 3 While boat is moving:

- a. Running the boat with the trim angle of the bow too high.
- b. Running the boat with no forward hatches open (station wagon effect).

# GENERAL INFORMATION

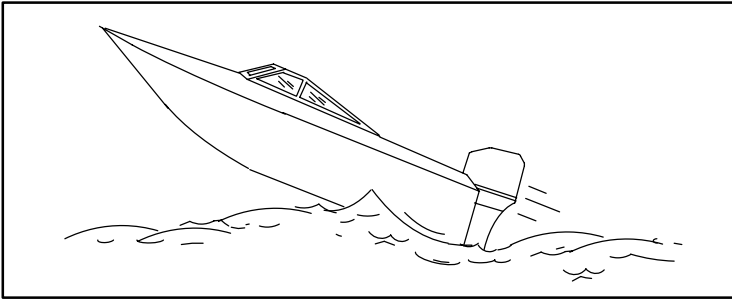

## Wave And Wake Jumping

Operating recreational boats over waves and wakes is a natural part of boating. However, when this activity is done with speed to force the boat hull partially or completely out of the water, certain hazards arise, particularly when the boat re-enters the water.

The primary concern is the boat changing direction while in the midst of the jump. In such case the landing may cause the boat to violently veer in a new direction. Such a sharp change in direction or turn can cause occupants to be thrown out of their seats or out of the boat.

There is another less common hazardous result from allowing your boat to launch off a wave or wake. If the bow of your boat pitches down far enough while airborne, upon water contact it may penetrate under the water surface and “submarine” for an instant. This will bring the boat nearly to a stop in an instant and can send the occupants flying forward. The boat may also steer sharply to one side.

### **WARNING**

**Avoid serious injury or death from being thrown within or out of a boat when it lands after jumping a wave or wake. Avoid wave or wake jumping whenever possible. Instruct all occupants that if a wake or wave jump occurs, get low and hang on to any boat hand hold.**

# GENERAL INFORMATION

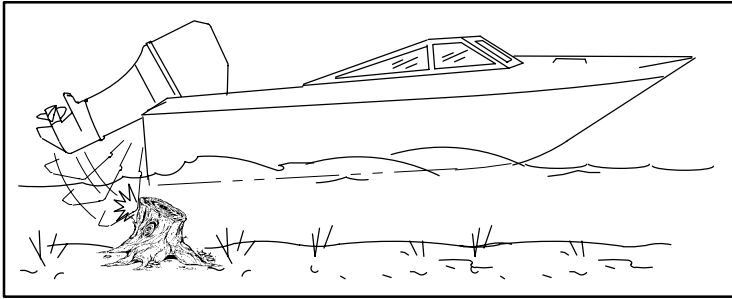

## Impact With Underwater Hazards

Reduce speed and proceed with caution whenever you're driving a boat in shallow water areas or in areas where the waters are suspected of having underwater obstacles that could be struck by the outboard or the boat bottom. **The most important thing you can do to help reduce injury or impact damage from striking a floating or underwater object is control the boat speed. Under these conditions, boat speed should be kept to a minimum planing speed (15 to 25 MPH).**

### **⚠ WARNING**

**To avoid serious injury or death from all or part of an outboard coming into the boat after striking a floating or underwater obstacle maintain a top speed no greater than minimum planing speed.**

Striking a floating or underwater object could result in an infinite number of situations. Some of these situations could result in the following:

- Part of the outboard or the entire outboard could break loose and fly into the boat.
- The boat could move suddenly in a new direction. Such a sharp change in direction or turn can cause occupants to be thrown out of their seats or out of the boat.
- A rapid reduction in speed. This will cause occupants to be thrown forward, even out of the boat.
- Impact damage to the outboard and/or boat.

(continued on next page)

# GENERAL INFORMATION

obn2

## Impact With Underwater Hazards (Continued)

Keep in mind, one of the most important things you can do to help reduce injury or impact damage in these situations is control the boat speed. Boat speed should be kept to a minimum planing speed when driving in waters known to have underwater obstacles.

After striking a submerged object, stop the engine as soon as possible and inspect the outboard for any broken or loose parts. If damage is present or suspected, the outboard should be taken to an authorized dealer for a thorough inspection and necessary repair.

The boat should also be checked for any hull fractures, transom fractures, water leaks.

Operating a damaged outboard could cause additional damage to other parts of the outboard, or could affect control of the boat. If continued running is necessary, do so at greatly reduced speeds.

### **WARNING**

**Avoid serious injury or death from from loss of boat control. Continued boating with major impact damage can result in sudden outboard component failure with or without subsequent impacts, Have the outboard thoroughly inspected and any necessary repairs made.**

# GENERAL INFORMATION

obj1

## Selecting Accessories For Your Outboard

Genuine Mercury Marine Accessories have been specifically designed and tested for your outboard.

Mercury Marine accessories are available from Mercury Marine dealers.

Some accessories not manufactured or sold by Mercury Marine are not designed to be safely used with your outboard or outboard operating system. Acquire and read the installation, operation, and maintenance manuals for all your selected accessories.

### **WARNING**

**Check with your dealer before installing accessories. Misuse of acceptable accessories or the use of unacceptable accessories can result in serious injury, death, or product failure.**

## Safe Boating Suggestions

In order to safely enjoy the waterways, familiarize yourself with local and other governmental boating regulations and restrictions, and consider the following suggestions.

**Use Life Jackets.** Have an approved life jacket of suitable size for each person aboard and have it readily accessible (it is the law). However we strongly recommend that everyone aboard wear their life jacket.

**Do not overload your boat.** Most boats are rated and certified for maximum load (weight) capacities (refer to your boat capacity plate). If in doubt, contact your dealer or the boats manufacturer.

**Perform safety checks and required maintenance.** Follow a regular schedule and ensure that all repairs are properly made.

**Know and obey all nautical rules and laws of the waterways.** Boat operators should complete a boating safety course. Courses are offered in the U.S.A. by (1) The U.S. Coast Guard Auxiliary, (2) The Power Squadron, (3) The Red Cross and (4) your state boating law enforcement agency. Inquiries may be made to the Boating Hotline, 1-800-368-5647 or the Boat U.S. Foundation information number 1-800-336-BOAT.

(continued on next page)



# GENERAL INFORMATION

## Safe Boating Suggestions (Continued)

**Make sure everyone in the boat is properly seated.** Don't allow anyone to sit or ride on any part of the boat that was not intended for such use. This includes backs of seats, gunwales, transom, bow, decks, raised fishing seats, any rotating fishing seat; anywhere that sudden unexpected acceleration, sudden stopping, unexpected loss of boat control or sudden boat movement could cause a person to be thrown overboard or into the boat.

**Never be under the influence of alcohol or drugs while boating (it is the law).** They impair your judgment and greatly reduce your ability to react quickly.

**Prepare other boat operators.** Instruct at least one person on board in the basics of starting and operating the outboard and boat handling in case the driver becomes disabled or falls overboard.

**Passenger boarding.** Stop the engine whenever passengers are boarding, unloading or are near the back (stern) of the boat. Just shifting the outboard into neutral is not sufficient.

**Be alert.** The operator of the boat is responsible by law to "maintain a proper lookout by sight (and hearing)." The operator must have an unobstructed view particularly to the front. No passengers, load, or fishing seats should block the operators view when operating the boat above idle speed.

**Never drive your boat directly behind a water skier in case the skier falls.** As an example, your boat traveling at 25 miles per hour (40 km/hr) in 5 seconds will overtake a fallen skier who was 200 feet (61m) in front of you.

**Boat operators are required by law to file a Boating Accident Report** with their state boating law enforcement agency when their boat is involved in certain boating accidents. A boating accident must be reported if: 1. there is loss of life or probable loss of life, 2. there is personal injury requiring medical treatment beyond first aid, 3. there is damage to boats or other property where the damage value exceeds \$500.00 or 4. there is complete loss of the boat. Seek further assistance from local law enforcement.

(continued on next page)

# Recording Serial Number

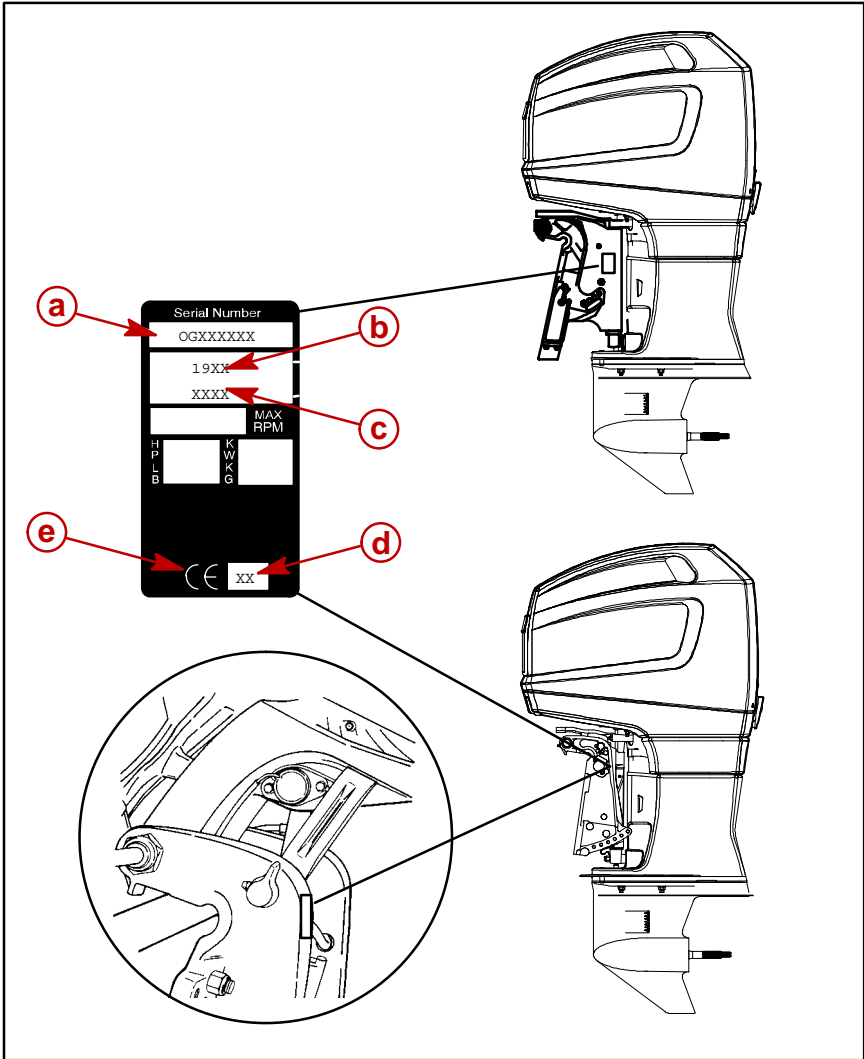

Record the following numbers from your engine as shown for future reference.

- a** - Serial Number
- b** - Model Year
- c** - Model Designation
- d** - Year Manufactured
- e** - Certified Europe Insignia

# GENERAL INFORMATION

## Specifications

<b>Models</b>	<b>300 - Pro Max 3.0L</b>
Propshaft Horsepower	300
Propshaft Kilowatts	224
ECU Box Rev Limit	6200
Idle RPM (In or Out of Gear)	650 RPM
Weight	465 lbs. (211 kg)
Piston Displacement	185 cu. in. (3044cc)
Bore	3.626 in. (92.1mm)
Stroke	3.00 in (76.2 mm)
Recommended Spark Plug	Champion QL77CC (.035" Gap)
Firing Order	1-2-3-4-5-6
Idle Speed Pickup Timing	Non Adjustable
Fuel Pressure	38-40 psi. (262-276 kPa)
Min. Water Pres. @ 7500 -5500 RPM	12 psi. Minimum
Gear Ratio	Fleetmaster 1.75:1 Torquemaster 1.75:1 Sportmaster 1.62:1 or 1.75:1
Recommended Gasoline	Refer to Fuel Section
Recommended Oil	Refer to Fuel Section
Recommended Gear Case Oil	Mercury Precision Hi-Performance Gear Lube (92-802854A1)
Gear Case Lubricant Cap.	27 fl. oz. (798 ml)
Battery Rating	Minimum reserve capacity rating of 100 minutes and CCA of 350
Charging System Output	60 amps Max. (847Watts)

# GENERAL INFORMATION

## Component Identification

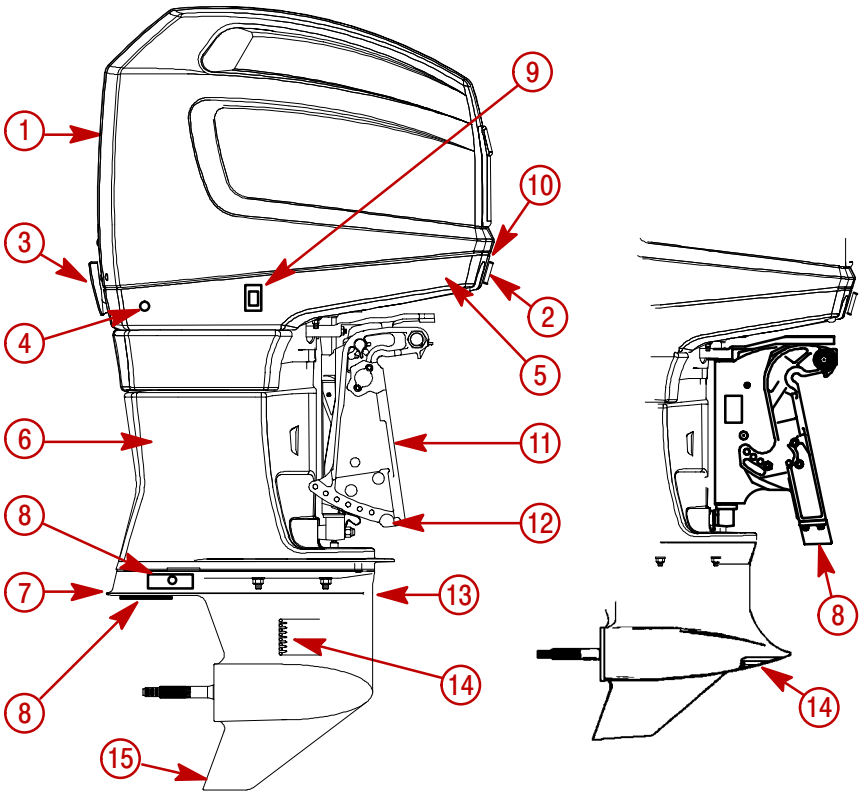

- |  |   |
|--|---|
| 1. Top Cowl                              | 9. Cowl Mount Trim Switch   |
| 2. Cowl Latch (Front)                    | 10. Wiring Harness, Fuel line and Control Cables (Install thru bottom cowl) |
| 3. Cowl Latch (Rear)                     | 11. Transom Brackets  |
| 4. Water Pump Indicator Hose (Tell-Tail) | 12. Trim Adjustment Bolt  |
| 5. Bottom Cowl                           | 13. Gear Case   |
| 6. Drive Shaft Housing                   | 14. Cooling Water Intake Holes  |
| 7. Anti-Ventilation Plate                | 15. Skeg  |
| 8. Corrosion Anode(s)                    |   |

# GENERAL INFORMATION

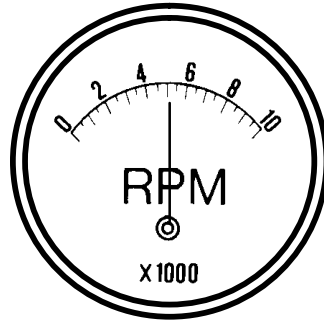
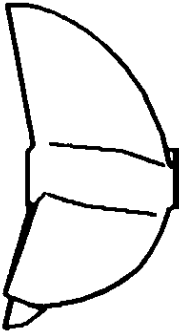

## Propeller Selection

Select a propeller that allows the engine to operate in the upper half of the recommended full throttle RPM range with the boat normally loaded (refer to Specifications).

If changing conditions (such as warmer, more humid weather, operation at higher elevations, increased boat load, or a dirty boat bottom/gear case) cause the RPM to drop below the recommended range a propeller change or boat cleaning may be required.

Check full-throttle RPM using an accurate tachometer with the engine trimmed out to a balanced-steering condition (steering effort equal in both directions) without causing the propeller to “break loose.”

# TRANSPORTING

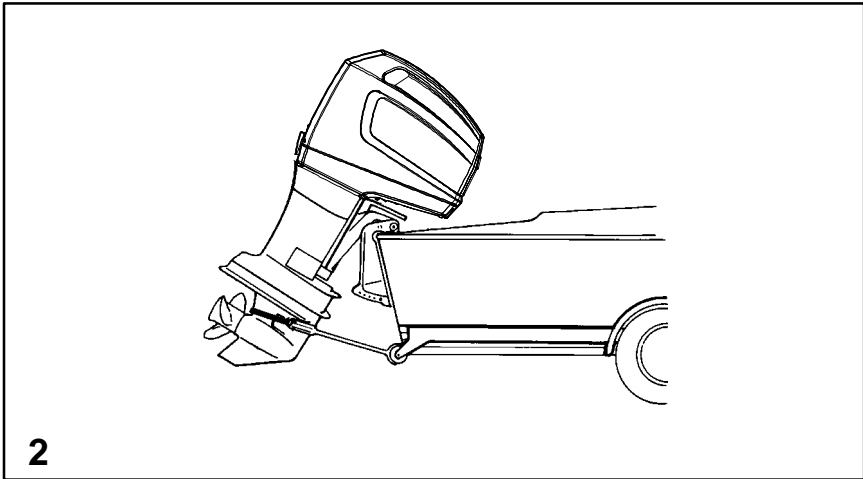
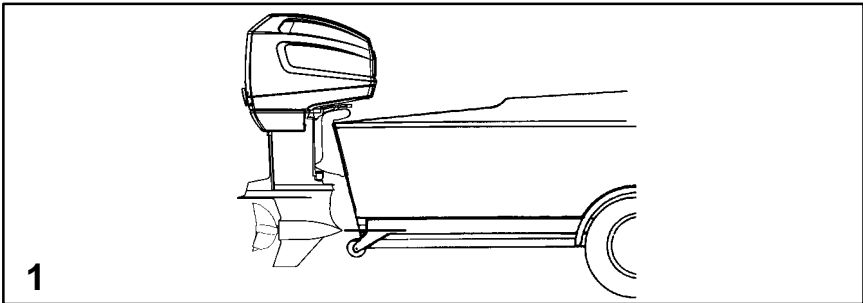

## Trailing Boat/Outboard

- 1** Trailer your boat with the outboard tilted down when ever possible (vertical operating position).
- 2** If additional ground clearance is required for, railroad crossings, driveways or trailer bouncing, support the outboard using a support device. Contact your local dealer for recommendations.

**IMPORTANT: Do not rely on the power trim/tilt system or tilt support lever to maintain proper ground clearance for trailing. The outboard tilt support lever is not intended to support the outboard for trailing.**

To prevent the propeller from spinning freely shift into forward gear.

# FUEL & OIL

## Gasoline Recommendations

### USA AND CANADA

Use a major brand of automotive unleaded gasoline with a minimum posted octane rating ( $R + M \div 2$ ) of 92. Automotive gasolines that contain fuel injector cleaner are recommended for added internal engine cleanliness.

### INTERNATIONAL

Use a major brand of automotive unleaded gasoline with a minimum posted octane rating of 98RON. Automotive gasolines that contain fuel injector cleaner are preferred for added internal engine cleanliness. Leaded gasoline is acceptable in areas where unleaded gasoline is not available. However, exhaust passageway corrosion may occur due to the accumulation of exhausted lead particles.

### GENERAL RECOMMENDATIONS

During periods of extended non use, a fuel stabilizer is highly recommended (See Storage Section).

Leaded Gasoline is acceptable to use in areas where unleaded is not available. However, exhaust passageway corrosion may occur due to the accumulation of exhausted lead particles.

### ALCOHOL IN GASOLINE

We do not recommend gasoline containing alcohol due to the possible adverse effect the alcohol may have on the fuel system. If only gasoline containing alcohol is available, it must not contain more than 10% ethanol or 5% methanol, and the addition of a Mercury Marine Water Separating Fuel Filter is recommended.

If gasoline containing alcohol is used or if you suspect the presence of alcohol in your gasoline, increase your inspection of the fuel system, visually checking for fuel leaks or abnormalities.

Gasoline containing alcohol may cause the following problems to your outboard and fuel system:

- Corrosion of metal parts.
- Deterioration of elastomers and plastic parts.
- Fuel penetrating through flexible fuel lines.
- Wear and damage of internal engine parts.

(continued on next page)

# FUEL & OIL

## ALCOHOL IN GASOLINE (CONTINUED)

- Starting and operating difficulties.
- Vapor lock or fuel starvation.

The tendency of gasoline containing alcohol to absorb moisture from the air, results in a phase of water and alcohol which separates from the gasoline in the fuel tank.

The adverse effects of alcohol are more severe with methanol and are worse with increasing content of alcohol.

## Oil Recommendation

Use Mercury Precision Premium Plus 2-Cycle TC-W3 Outboard Oil.

**Emergency Use Only:** If Mercury Precision Premium Plus 2-Cycle TC-W3 Outboard Oil is not available, NMMA Certified 2-Cycle TC-W3 Oil may be substituted.

Periodically consult with your dealer to get the latest gasoline and oil recommendations. If Mercury Precision Premium 2-Cycle TC-W3 Outboard Oil is not available, substitute a 2-Cycle outboard manufacturers oil that is NMMA Certified TC-W3, or another brand of 2-Cycle outboard oil that is NMMA Certified TC-W3. The use of an inferior 2-Cycle outboard oil can reduce engine durability. **Damage from use of inferior oil may not be covered under the limited warranty.**



# FUEL & OIL

## Filling Fuel Tank

### **WARNING**

**Avoid serious injury or death from a gasoline fire or explosion. Always stop the engine and DO NOT smoke or allow open flames or sparks in the area while filling fuel tanks. To help prevent a static charge during filling, portable fuel tanks must be removed from the boat and placed directly on the ground for filling.**

1. Fill fuel tanks outdoors away from heat, sparks, and open flames.
2. Remove portable fuel tanks from boat to refill them.
3. Always stop engine before refilling tanks.
4. Do not completely fill the fuel tanks. Leave approximately 10% of the tank volume unfilled. Fuel will expand in volume as its temperature rises and can leak under pressure if the tank is completely filled.

# FUEL & OIL

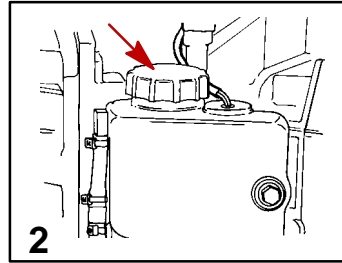
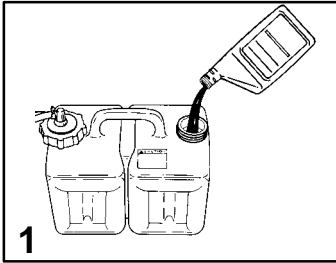

## Filling Remote Oil Tank

- 1 Remove filler cap and fill with the specified oil. Oil tank capacity is 3 gallons (11.5 liters). Replace filler cap and tighten securely.

**IMPORTANT:** Always make sure the oil tank caps are threaded on tight. An air leak will prevent oil flow to the engine.

**NOTE:** Prior to running the engine, mark the oil level in the remote oil supply tank for later reference. At the end of the break-in period, visually check to see if the oil level in the remote oil supply tank has dropped. Oil usage indicates the oil injection system is functioning correctly.

## Filling Engine Mounted Oil Reservoir Tank

**NOTE:** Filling this tank is only necessary if the oil level should ever drop and the low oil warning system is activated.

- 2 Remove top cowl. Loosen engine mounted oil reservoir tank filler cap and fill the remote oil tank with the specified oil. Run engine until the oil reservoir tank is filled by the remote tank. Tighten the oil reservoir tank cap securely. Stop the engine and replace the top cowl.

# FEATURES & CONTROLS

gog142

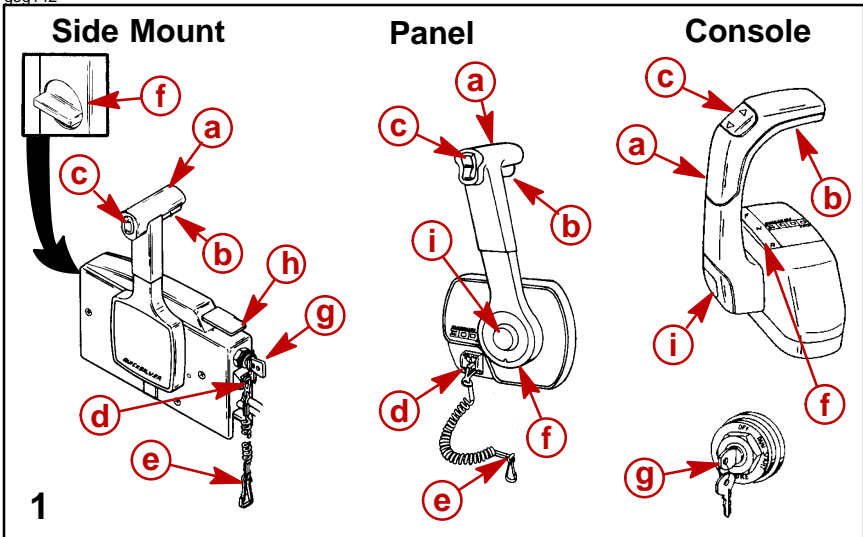

oge5

## Remote Control Features

**1** Your boat may be equipped with one of the Mercury Precision remote controls shown. If not, consult your dealer for operation of your remote control.

- a** - Control Shift/Throttle Handle
- b** - Neutral Release Lever
- c** - Trim/Tilt Switch
- d** - Lanyard Stop Switch – Read the Lanyard Stop Switch safety explanation and Warning in the General Information Section.
- e** - Lanyard – Read the lanyard stop switch safety explanation and warning in the General Information Section.
- f** - Throttle Friction Adjustment
- g** - Ignition Key Switch, Choke
- h** - Fast Idle Lever – Raising lever will increase engine idle speed in neutral.
- i** - Throttle Only Button – Pushing the button in will enable advancing the control handle and increase engine idle speed without shifting outboard into gear.

# FEATURES & CONTROLS

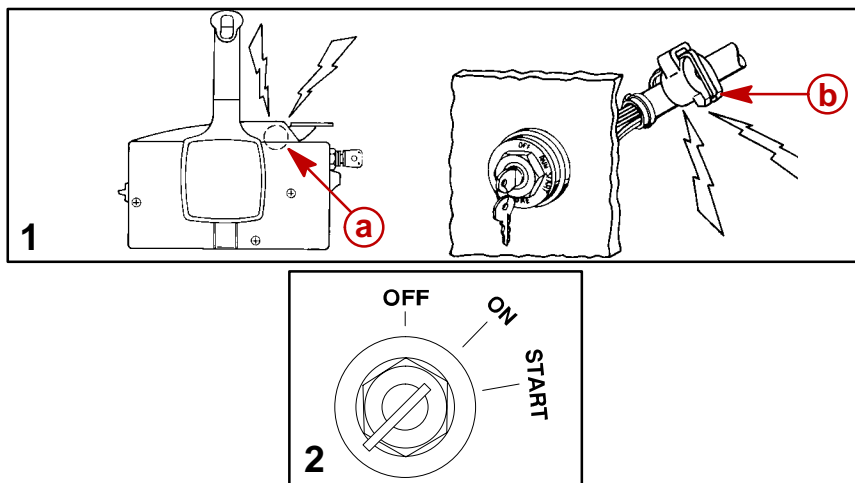

## Warning Horn System

- 1 A warning horn may be located inside the remote control (a) or under the dash (b) connected to the ignition key switch. The warning horn sounds when one of the following outboard warning systems is activated.
  - Low oil level in oil injection system (see explanation following).
  - Engine over-speed protection system is activated (see explanation following).
  - An electrical sensor not functioning (see explanation following).
  - Engine overheat (see explanation following).
  - Water in fuel filter reaches full level (see explanation following).
- 2 When the ignition key is initially turned on, the warning horn will sound for a moment as a test to tell you the system is working. Failure of this test indicates a problem. Have the outboard checked by your dealer.

**NOTE:** If you are in a stranded situation, stopping the engine and allowing it to cool down will usually allow some additional low speed (idle) running time before the engine starts to overheat again.

**IMPORTANT:** The overheat problem must be corrected before you can resume normal operation.

(continued on next page)

# FEATURES & CONTROLS

## Warning Horn System (Continued)

### LOW OIL LEVEL

The low oil level warning is activated when the remaining oil in the engine mounted oil reservoir tank drops below 50 fl. oz. (1.5 liters) You still have an oil reserve remaining for 50 minutes of full speed operation.

**IMPORTANT: The engine mounted oil reservoir tank (located beneath the top cowl) along with the remote oil tank will have to be refilled (refer to Fuel & Oil Section).**

The low oil level warning system works as follows:

- 3** The warning horn will begin a series of four beeps. If you continue to operate the outboard, the horn will beep every two minutes. The engine has to be shut off to reset the warning system.

### CAUTION

**To avoid engine damage caused by running out of oil, it is best to refill the oil injection system as soon as the low oil warning is activated.**

(continued on next page)

# FEATURES & CONTROLS

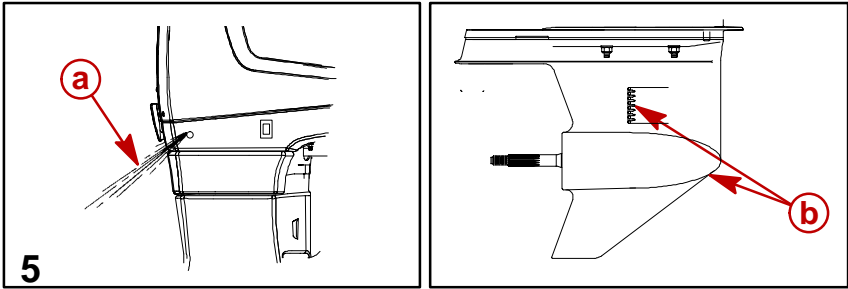

## Warning Horn System (Continued)

### ENGINE OVERHEAT

The engine overheat warning is activated when the engine temperature is too hot.

The engine overheat warning system works as follows:

- 4** The warning horn sounds continuously. The warning system will automatically limit the engine speed to 3000 RPM.
- 5** If the engine overheats, immediately reduce throttle speed to idle. Shift outboard into neutral and check for a steady stream of water coming out of the water pump indicator hole (a).

### **CAUTION**

**Operating the engine while overheated will cause engine damage. The overheat problem must be corrected before you can resume normal operation.**

- a. **If no water is coming out of the water pump indicator hole (a) or flow is intermittent:**
  - Stop engine and check cooling water intake holes for obstruction.
  - If no obstruction is found, this may indicate a blockage in the cooling system or a water pump problem.
  - Have the outboard checked by your dealer.
- b. **If a steady stream of water is coming out of the water pump indicator hole (a) and warning horn continues:**
  - There may be insufficient cooling water or an engine problem.
  - Stop engine and have it checked by your dealer.

(continued on next page)

# FEATURES & CONTROLS

ogb18

## Warning System (Continued)

### ENGINE OVER-SPEED PROTECTION SYSTEM

The engine over-speed protection system is activated when the engine speed exceeds the maximum allowable RPM.

The engine over-speed protection system works as follows:

- 6** Anytime the engine over-speed system is activated, the warning horn begins beeping. In addition, the system will automatically reduce the engine speed to within the allowable limit by retarding the ignition timing.

**NOTE:** *Your engine speed should never reach the maximum limit to activate the system unless the propeller is ventilating, an incorrect propeller is being used, or the propeller is faulty. If engine over-speed continues, have the outboard checked by your dealer.*

### ELECTRICAL SENSOR NOT FUNCTIONING

The warning system is activated if an electrical engine sensor is not functioning, or is out of its operating range.

The warning system works as follows:

- 7** The warning horn begins beeping. Have the outboard checked by your dealer.

### WATER SEPARATING FUEL FILTER IS FULL OF WATER ON ENGINES WITH ELECTRONIC FUEL INJECTION (EFI)

The water level detection warning is activated when water in the water separating fuel filter reaches the full level. The water can be removed from the filter. Refer to Maintenance Section for filter removal.

- 8** The warning horn will begin a series of four beeps. If you continue to operate the outboard, the horn will beep every two minutes.

# FEATURES & CONTROLS

gog70

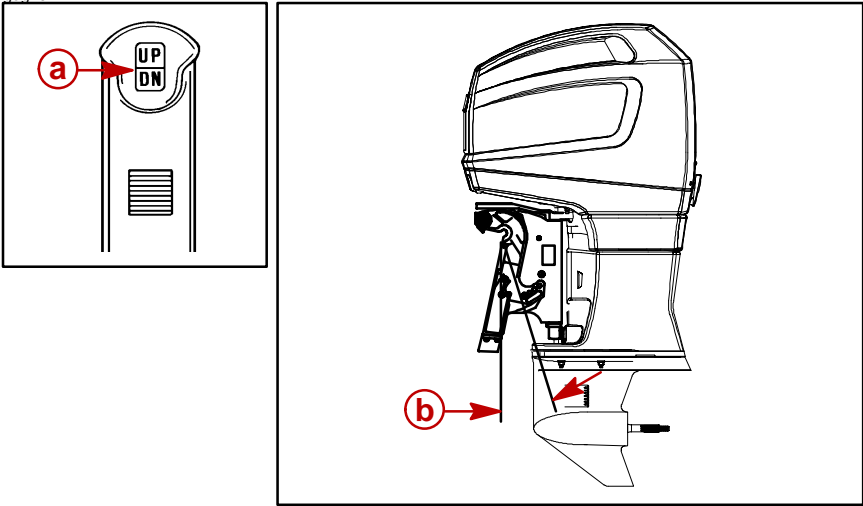

## Power Trim And Tilt

Outboard position can be adjusted by pressing trim switch (a). This range is used while operating your boat on plane.

- **Pressing (DN):** Moves the outboard in closer to the boat transom, called trimming “in” or “down.”
- **Pressing (UP):** Moves the outboard further away from the boat transom, called trimming “out” or “up.”

### The term “trim”:

- Generally refers to the adjustment of the outboard within the first 20° range of travel (b).

### The term “tilt”:

- Generally refers to adjusting the outboard further up out of the water.

With the engine turned off, the outboard can be tilted out of the water. At low idle speed, the outboard can also be tilted up past the trim range to permit, for example, shallow water operation.

(continued on next page)



# FEATURES & CONTROLS

osf1

## Power Trim Operation

With most boats, operating around the middle of the “trim” range will give satisfactory results. Trimming your outboard all the way in or out may improve performance but cause some potential control hazards.

### **WARNING**

**Avoid possible serious injury or death. When the outboard is trimmed in or out beyond a neutral steering condition, a pull on the steering wheel in either direction may result. Failure to keep a continuous firm grip on the steering wheel when this condition exists can result in loss of boat control as the outboard can turn freely. The boat can now “spin out” or go into a very tight maximum turn which, if unexpected, can result in occupants being thrown within the boat or out of the boat.**

Consider the following lists carefully.

Trimming In or Down Can:

- Lower the bow of the boat.
- Result in quicker planing off.
- Generally improve the ride in choppy water.
- Increase steering torque or pull to the right (with the normal right hand rotation propeller).
- In excess, lower the bow to a point at which the boat begins to plow with the bow in the water while on plane. This can result in an unexpected turn in either direction called “bow steering” or “over steering” if any turn is attempted, or if a significant wave is encountered.

(continued on next page)

# FEATURES & CONTROLS

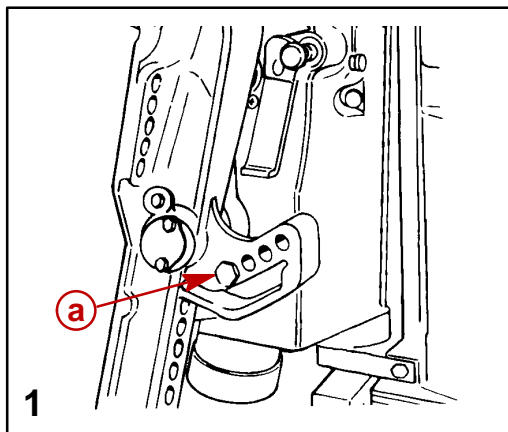

## Power Trim Operation (continued)

### **⚠ WARNING**

**Avoid possible serious injury or death. Adjust outboard to an intermediate trim position as soon as boat is on plane to avoid possible ejection due to boat spin-out. Do not attempt to turn boat when on plane if outboard is trimmed extremely in or down and there is a pull on the steering wheel.**

- 1** The trim in limit may be set by inserting the tilt pin (a) into the desired transom bracket hole.

Trimming Out or Up can:

- Lift the bow higher out of the water.
- Generally increase top speed.
- Gain clearance over submerged objects or a shallow bottom.
- Increase steering torque or pull to the left at a normal installation height (with the normal right hand rotation propeller).
- In excess, cause boat “porpoising” (bouncing) or propeller ventilation.
- Cause engine overheating if any cooling water intake holes are above the water line.

# FEATURES & CONTROLS

gog62

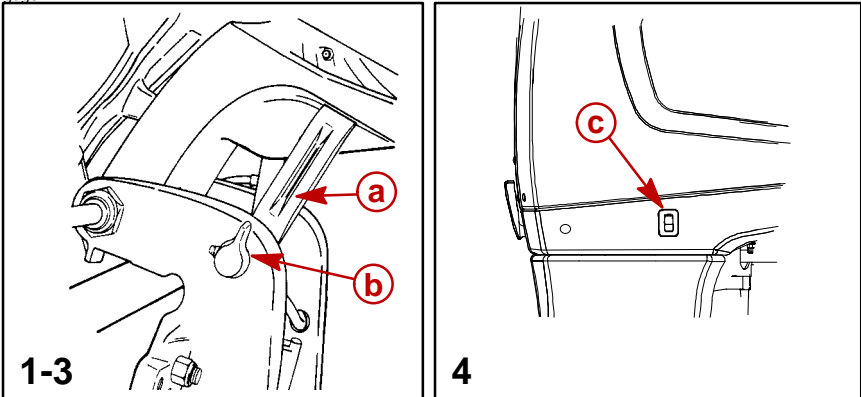

## Tilting Operation (Fleet Master & Torque Master Gear Cases)

To tilt outboard, shut off the engine and press the trim/tilt switch or auxiliary tilt switch to the up position. The outboard will tilt up until the switch is released or it reaches its maximum tilt position.

- 1** Engage the tilt support lever (a), by pushing in and rotating knob (b) to bring support lever upward.
- 2** Lower outboard to rest on the tilt support lever.
- 3** Disengage the tilt support lever, by raising the outboard off the support lever and rotating the lever down. Lower the outboard.

osc1

## Auxiliary Tilt Switch

- 4** This switch (c) can be used to tilt the outboard up or down using the power trim system.

(continued on next page)

# FEATURES & CONTROLS

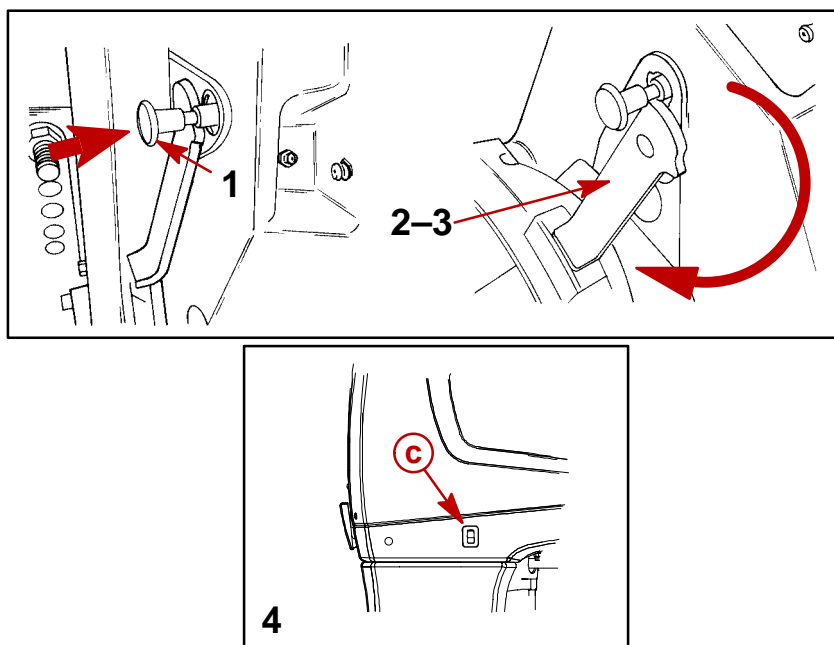

## Tilting Operation (Sport Master Gear Case)

To tilt outboard, shut off the engine and press the trim/tilt switch to the up position. The outboard will tilt up until the switch is released or it reaches its maximum tilt position.

- 1** Push in on the tilt support release knob.
- 2** Move tilt support lever into locking position and lower outboard to rest on the tilt support lever.
- 3** Disengage the tilt support lever by raising the outboard off the support lever and rotating the lever up until it locks. Lower the outboard.

osc1

## Auxiliary Tilt Switch

- 4** This switch (c) can be used to tilt the outboard up or down using the power trim system.

# FEATURES & CONTROLS

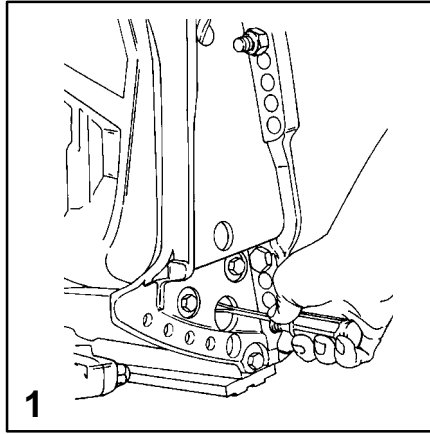

## Manual Tilting (Fleet Master & Torque Master Models Only)

If the outboard cannot be tilted using the power trim/tilt switch, the outboard can be manually tilted.

- 1** Turn out the manual tilt release valve 3 turns (counterclockwise). This allows manual tilting of the outboard. Tilt the outboard to the desired position and tighten the manual tilt release valve.

**NOTE:** *The manual tilt release valve must be tightened before operating the outboard to prevent the outboard from tilting up during reverse operation.*

# FEATURES & CONTROLS

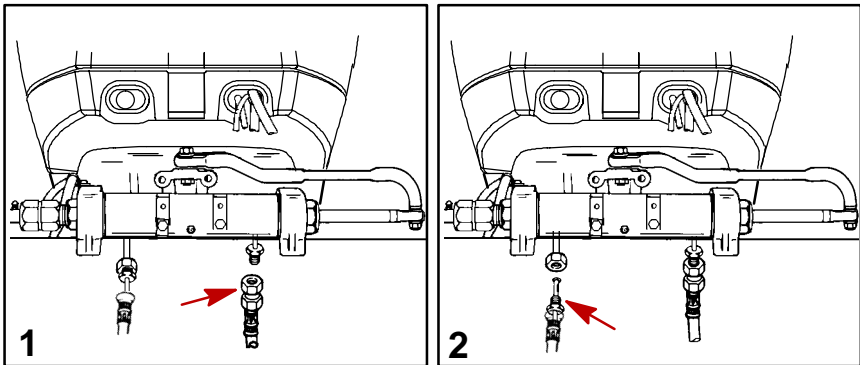

## Manual Tilting (Sportmaster Models)

If the outboard cannot be tilted using the power trim/tilt switch, the outboard can be manually tilted by the following procedures.

### **⚠ CAUTION**

**The engine must be supported during lowering in the following steps or the engine may drop rapidly and personal injury as well as damage to the engine could occur.**

**NOTE:** Place a suitable container below the connection and wrap the connection with a cloth to collect any fluid which may be dispelled during the following operations.

### **1 TILTING (DOWN / IN):**

- Loosen the (starboard-right, facing engine from front) hydraulic connection at the front of the swivel bracket.
- Slowly lower the engine to the desired position, and reconnect the hydraulic connection.

### **2 TILTING (UP / OUT):**

- Loosen the (port-left, facing engine from front) hydraulic connection at the front of the swivel bracket.
- Slowly lift the engine and engage the tilt lock lever. Reconnect the hydraulic connection.

**IMPORTANT:** If the hydraulic lines are disconnected and fluid is lost, the power trim pump must be refilled and the lines purged of air.

# OPERATION

## Engine Break-in

### CAUTION

Severe damage to the engine can result by not complying with the Engine Break-in Procedure.

### BREAK-IN PROCEDURE

For the first 30 gals. (114 L) of fuel mixture, mix oil in the fuel tank at 25:1 (4%). This is in addition to the oil supplied to the engine by the oil injection system. (See following chart)

Always vary throttle settings during Break-in

#### 1st HOUR

- Allow engine to warm-up for 30 - 60 seconds.
- Do not idle for more than 10 minutes
- Run the engine the majority of time between 3000 - 4500 RPM (approximately three quarter throttle).
- Short bursts of full throttle for periods up to 10 seconds are acceptable.
- Vary engine speed. Change engine speed approximately every two (2) minutes.
- Avoid trimming the outboard out (up) beyond a vertical trim position during operation.
- Avoid using hydraulic jack plate (if equipped) to raise engine during break-in cycle.

**NEXT 3 HOURS:** Change engine speed every 10 minutes.

### CAUTION

It is the boat operators responsibility to always drive in a safe manner. Improper trim angle of the outboard when driving at speed can be difficult and dangerous. Trim angle is specified to help guide the operator in determining how to put the proper load on the engine during the break-in period. These guidelines do not suggest or require unsafe boat operation.

# OPERATION

## Engine Break-in (con't)

oeh2

### GASOLINE/OIL MIXTURE (FIRST 30 GAL [114L] OF FUEL)

<b>Gas/Oil Ratio</b>	<b>1 US Gal. Gas (3.8 L)</b>	<b>3 Gallons Gas (11.5 L)</b>	<b>6 Gallons Gas (23 L)</b>	<b>30 US Gal. Gas (114 L)</b>
<b>25:1 (4 %)</b>	5 fl. oz. (148 ml) Oil	15 fl. oz. (444 ml) Oil	31 fl. oz. (917 ml) Oil	4.75 US qt (4.5 L) Oil

### GASOLINE RECOMMENDATION

Use a major brand of automotive unleaded gasoline with a minimum posted octane rating (R + M ÷ 2) of 92.

### OIL RECOMMENDATION

Use Mercury Precision Premium Plus 2-Cycle TC-W3 Outboard Oil.



# OPERATION

## Pre-Starting Check List

- Operator knows safe navigation, boating/operating procedures.
- An approved personal flotation device of suitable size for each person aboard and readily accessible (it is the law).
- A ring type life buoy or buoyant cushion designed to be thrown to a person in the water.
- Know your boats maximum load capacity. Look at the boat capacity plate.
- Arrange passengers and load in the boat so the weight is distributed evenly and everyone is seated in a proper seat.
- Tell someone where you are going and when you expect to return.
- It is illegal to operate a boat while under the influence of alcohol or drugs.
- Know the waters and area you will be boating; tides, currents, sand bars, rocks, and other hazards.
- Engine lowered to run position with all water intake holes submerged.
- Fuel tank vent cap open or fuel petcock "On".
- Fuel supply OK.
- Oil supply (oil injection) OK.
- Lanyard stop switch in "Run" position and cord connected.
- Remote control in "Neutral".
- Top cowl latches secure.
- Make inspection checks listed in the Inspection and Maintenance Schedule. Refer to Maintenance Section.

# OPERATION

onf2

## Operating In Freezing Temperatures

When using your outboard or having your outboard moored in freezing or near freezing temperature, keep the outboard tilted down at all times so the gear case is submerged. This prevents trapped water in gear case from freezing and causing possible damage to the water pump and other components.

If there is a chance of ice forming on the water, the outboard should be removed and drained completely of water. If ice should form at the water level inside the outboard drive shaft housing, it will block water flow to the engine causing possible damage.

one1

## Operating In Salt Water Or Polluted Water

We recommend flushing the internal water passages of your outboard with fresh water after each use in salt or polluted water to prevent a buildup of deposits from clogging the water passages. Refer to “Flushing The Cooling System” procedure in the Maintenance Section.

If you keep your boat moored in the water, always tilt the outboard so the gear case is completely out of water (except in freezing temperature) when not in use.

Wash down the outboard exterior and flush out the exhaust outlet of the propeller and gear case with fresh water after each use. Each month, spray Mercury Precision Corrosion Guard (92-802878-55) on external metal surfaces (do not spray on corrosion control anodes as this will reduce the effectiveness of the anodes).

## Operating At High Elevations

Your engine automatically compensates for high elevation changes. A different pitch propeller may help reduce some normal performance loss resulting from reduced oxygen in the air. Consult your dealer.

# OPERATION

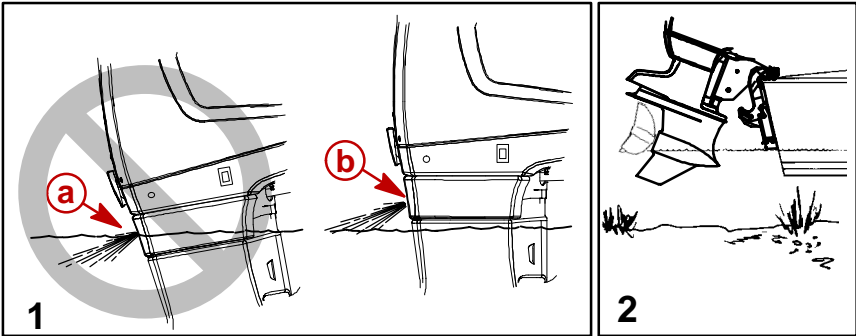

onn2

## Setting Trim Angle While Running Engine at Idle Speed

- 1 Submerging the exhaust relief hole (a) on the outboard can happen on some boats if you trim “full-in” while running at idle speed, resulting in, exhaust restriction, rough idle, excessive smoke, and fouled spark plugs. If this condition exists, trim outboard up until exhaust relief hole is out of the water (b).

onk2

## Operating in Shallow Water

- 2 When operating in shallow water, you can tilt the outboard beyond the maximum trim range to prevent hitting bottom.
  - a. Operate the engine at slow speed only. Do Not exceed 1200 RPM with the outboard trimmed beyond the side supports of the swivel bracket.
  - b. Tilt outboard up. Make sure all the cooling water intake holes stay submerged at all times.

# OPERATION

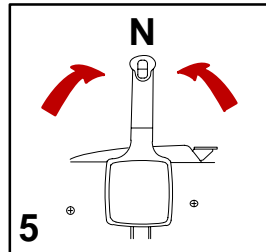
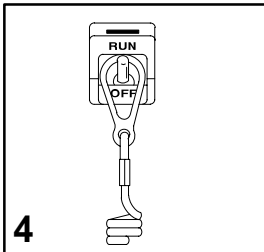
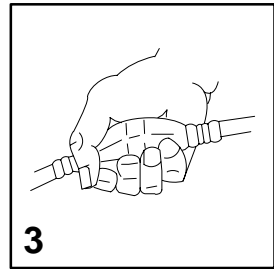
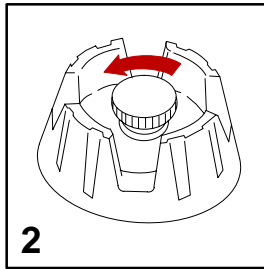
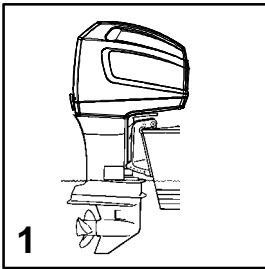

## Starting The Engine

Before starting, read the Pre-Starting Check List, Special Operating Instructions, in the Operation Section.

### **CAUTION**

**Never start or run your outboard (even momentarily) without water circulating through all the cooling water intake holes in the gear case to prevent damage to the water pump (running dry) or overheating of the engine.**

- 1** Lower the outboard to the run position. Make sure all the cooling water intake holes are submerged.
- 2** Open fuel tank filler cap vent screw (manual venting fuel tanks).
- 3** Squeeze the fuel line primer bulb several times until it feels firm.
- 4** Set the lanyard stop switch to RUN position. Read the Lanyard Stop Switch safety explanation and Warning in the General Information Section.
- 5** Shift outboard to neutral (N) position.

(continued on next page)

# OPERATION

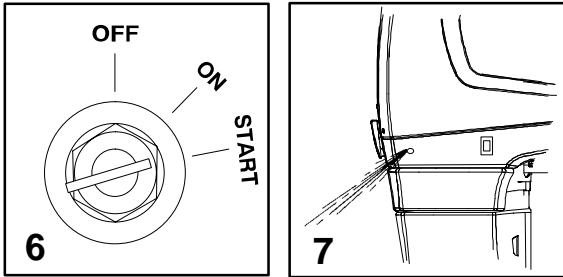

## Starting The Engine (Continued)

**NOTE:** It is not necessary to use the neutral fast idle speed feature on the remote control to increase engine speed for starting and warm up. The electronic starting system will automatically increase idle speed for starting and will reduce it as the engine warms up. The engine does not require you to actuate the primer (choke) for starting. The electronic starting system will automatically prime the engine.

- 6** Turn the ignition key to START position. Release the key when engine starts. If engine fails to start in 10 seconds, return the key to ON position, wait 30 seconds and try again.

**NOTE:** Starting Flooded Engine – Advance the neutral high idle speed feature on the remote control to the full high speed position. Crank engine for 10 seconds, wait 30 seconds and repeat until engine starts.

- 7** Check for a steady stream of water flowing out of the water pump indicator hole (allow approximately 10-15 seconds for the water flow to start).

**IMPORTANT:** If no water is coming out of the water pump indicator hole, stop engine and check cooling water intake holes for obstruction. No obstruction may indicate a water pump failure or blockage in the cooling system. These conditions will cause the engine to overheat. Have the outboard checked by your dealer. Operating the engine while overheated will cause engine damage.

(continued on next page)

# OPERATION

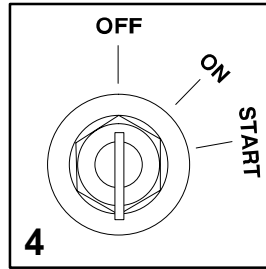
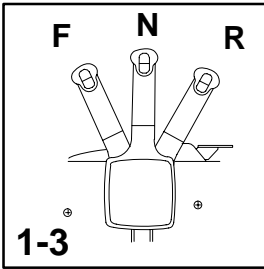

## Starting The Engine (Continued)

### Gear Shifting

**IMPORTANT:** Observe the following:

- **Never shift outboard into gear unless engine is at idle.**
  - **Never shift outboard into Reverse without the engine running.**
- 1** Your outboard has three gear shift positions to provide operation. Forward (F), Neutral (out of gear) and Reverse (R).
  - 2** When shifting, always stop at neutral position and allow the engine speed to return to idle.
  - 3** Always shift outboard into gear with a quick motion.

### Stopping The Engine

- 4** Reduce engine speed and shift outboard to neutral position. Turn ignition key to OFF position.

# OPERATION

gof84

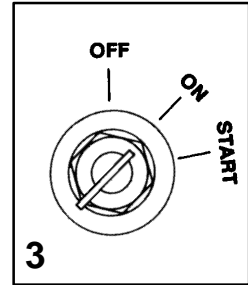
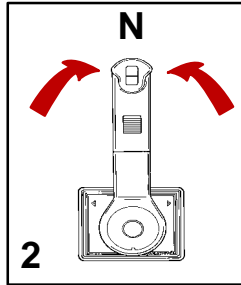
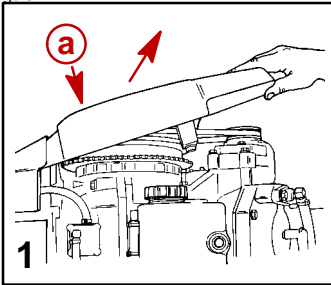

ofp14

## Emergency Starting

If the starter system fails, use a spare starter rope (not provided) and follow procedure.

**IMPORTANT: Electronic Fuel Injected (EFI) models – If the battery voltage drops below 8 volts, the electric fuel pump will not operate. With this low battery voltage condition, the engine cannot be manually started.**

- 1 Remove flywheel cover (a). Refer to Maintenance Section.
- 2 Shift outboard to neutral (N) position.

### **⚠ WARNING**

**When using emergency starter rope to start engine, the start-in-gear protection provided by the remote control is inoperative. Make sure to set the outboard gear shift into neutral to prevent outboard from starting in gear. Sudden unexpected acceleration could result in serious injury or death.**

- 3 Turn the ignition key to ON position.

(continued on next page)

# OPERATION

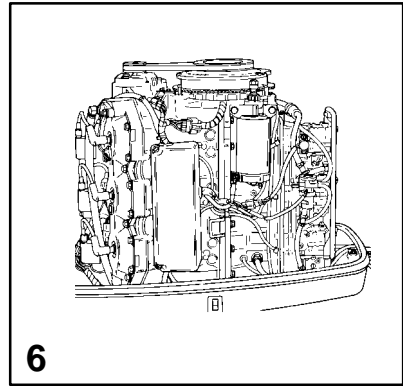
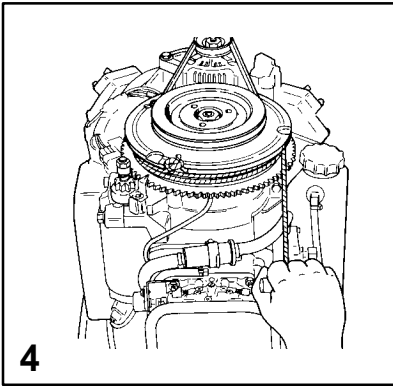

## Emergency Starting (Continued)

### ⚠ WARNING

To prevent getting an electrical shock, DO NOT touch any ignition component, wiring or spark plug wire when starting or running the engine.

### ⚠ WARNING

The exposed moving flywheel can cause serious injury. Keep your hands, hair, clothing, tools, and other objects away from engine when starting or running the engine. Do not attempt to reinstall the flywheel cover or top cowl when engine is running.

- 4 Place the rope knot into the flywheel notch and wind the rope clockwise around the flywheel under the alternator belt.
- 5 Pull the starter rope to start the engine.
- 6 After engine has started, do not reinstall the flywheel cover or top cowl until the engine has been stopped.



# MAINTENANCE

## Outboard Care

To ensure safety and retain dependability keep your outboard in the best operating condition by performing the periodic inspections and maintenance listed in the Inspection and Maintenance Schedule. Record maintenance performed in Maintenance Log at the back of this book. Save all maintenance work orders and receipts.

ohr1

### WARNING

**Neglected outboard inspection and maintenance or performing maintenance or repairs you are not familiar with, could result in personal injury, death or product failure.**

## Submerged Outboard

A submerged outboard will require service within a few hours by an authorized dealer once the outboard is recovered. This immediate attention is necessary once the engine is exposed to the atmosphere to minimize internal corrosion damage to the engine.

## Selecting Replacement Parts For Your Outboard

We recommend using original Mercury Precision replacement parts and Lubricants.

### WARNING

**Using a replacement part that is inferior to the original part could result in personal injury, death, or product failure.**

oti1

## EPA Emissions Regulations

All new outboards manufactured by Mercury Marine are certified to the United States Environmental Protection Agency as conforming to the requirements of the regulations for the control of air pollution from new outboard motors. This certification is contingent on certain adjustments being set to factory standards. For this reason, the factory procedure for servicing the product must be strictly followed and, wherever practicable, returned to the original intent of the design. **Maintenance, replacement, or repair of the emission control devices and systems may be performed by any marine SI engine repair establishment or individual.**

# MAINTENANCE

## Inspection And Maintenance Schedule

### BEFORE EACH USE

1. Check that lanyard stop switch stops the engine.
2. Visually inspect the fuel system for deterioration or leaks.
3. Check outboard for tightness on transom.
4. Check steering system for binding or loose components.
5. Visually check steering link rod fasteners for proper tightness.
6. Check propeller blades for damage.

### AFTER EACH USE

1. Flush out the outboard cooling system if operating in salt or polluted water.
2. If operating in salt water, wash off salt deposits and flush propeller and gear case exhaust outlet with fresh water.

### EVERY 50 HOURS OF USE

1. Lubricate all lubrication points. (More frequently in salt water).
2. Inspect and clean/replace spark plugs.
3. Check corrosion control anodes. (More frequently in salt water).
4. Check fuel pressure.\*
5. Drain and replace gear case lubricant.
6. Inspect battery.

\* *These items should be serviced by an authorized dealer.*

(continued on next page)

# MAINTENANCE

## Inspection And Maintenance Schedule (Continued)

### EVERY 50 HOURS OF USE (CONT.)

7. Check engine timing setup.\*
8. Check control cable adjustments. \*
9. Check alternator belt tension.
10. Check tightness of bolts, nuts, and other fasteners.

### EVERY 100 HOURS OF USE OR ONCE YEARLY, WHICHEVER OCCURS FIRST

1. Check power trim fluid.
2. Replace Water separating fuel filter.
3. Lubricate splines on the drive shaft and prop shaft. (If used in salt water, more frequent service may be needed.)\*
4. Torque Master and Sport Master Gearcases – Lubricate entire length of driveshaft with Mercury Precision anti-corrosion grease. (92-802867A1) (If used in salt water, more frequent service may be needed.)\*
5. Inspect fiberglass reeds for chipping or cracks.\*
6. Use Mercury Precision QuickKleen (92-802877A1) in fuel.

### EVERY 300 HOURS OR USE OR THREE YEARS

1. Replace water pump impeller (more often if: overheating occurs, used in salt water, or reduced water pressure is noted).\*
2. Replace cylinder head O-ring seals.\*

### BEFORE PERIODS OF STORAGE

1. Refer to Storage procedure.

\* *These items should be serviced by an authorized dealer.*

# MAINTENANCE

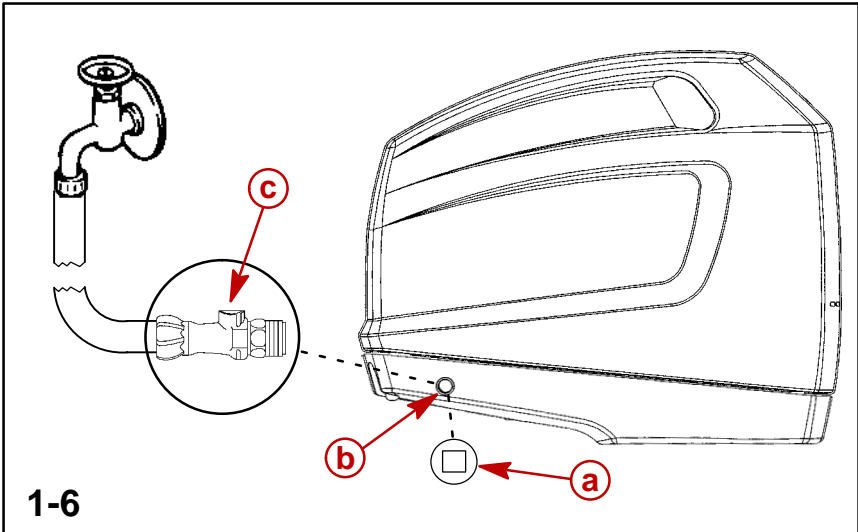

## Flushing the Cooling System - Using Cowl Flushing Attachment

**NOTE:** Let engine cool to ambient temperature before flushing system.

Flush the internal water passages of the outboard with fresh water after each use in salt, polluted or muddy water. This will help prevent a buildup of deposits from clogging the internal water passages.

**NOTE:** Engine should not be running when flushing the cooling system. Do not flush engine using a water system that exceeds 45 psi.

- 1** Remove plug (a) from valve body (b) in the bottom cowl (port side).
- 2** Attach coupling assembly (22-852400) (c) to the valve body (b), located in the bottom cowl (port side).
- 3** Attach a water hose to the coupling assembly (c).
- 4** Turn water supply on and flush engine for 3 to 5 minutes. Verify water dump from tell-tale hose.
- 5** Turn off the water, and remove the flushing attachment.
- 6** Insert plug (a) into valve body (b) (tighten securely).

# MAINTENANCE

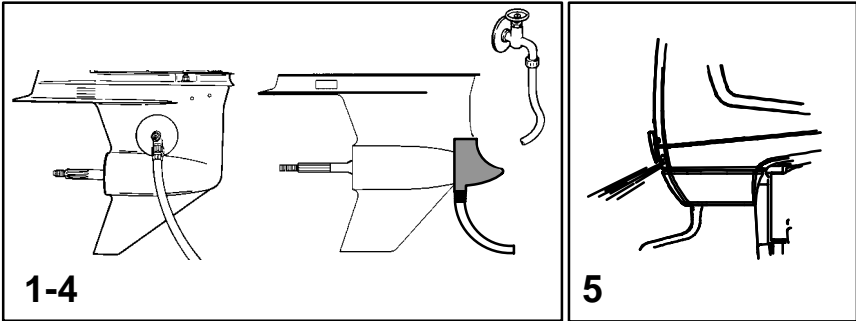

## Flushing the Cooling System (Continued) - Using Gear Case Flushing Attachments

### **⚠ WARNING**

**To avoid possible injury when flushing, remove the propeller. Refer to Propeller Replacement.**

- 1** Remove propeller (refer to Propeller Replacement). Install the flushing attachment to fit tightly over the cooling water intake.
- 2** Attach a water hose to the flushing attachment. Turn on the water and adjust the flow so water is leaking around the flushing attachment to ensure the engine receives an adequate supply of cooling water.
- 3** Start the engine and run it at idle speed in neutral shift position.
- 4** Adjust water flow so excess water continues leaking out from around the flushing attachment to ensure the engine is receiving an adequate supply of cooling water.
- 5** Check for a steady stream of water flowing out of the water pump indicator hoses. Continue flushing the outboard for 3 to 5 minutes, carefully monitoring water supply at all times.
- 6** Stop the engine, turn off the water, and remove the flushing attachment. Reinstall the propeller.

# MAINTENANCE

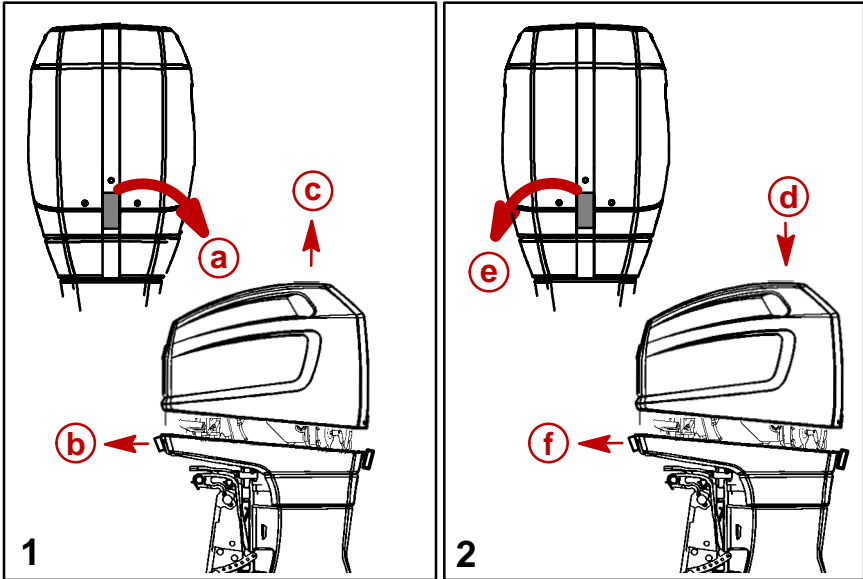

## Top Cowl Removal and Installation

### **⚠ WARNING**

**Avoid Serious Injury or Death. Do Not attempt to remove or install cowl while engine is running.**

### 1 Removal

- a** - Rotate rear latching handle clockwise.
- b** - Pull out on front latching handle and at the same time lift front of cowl.
- c** - Lift cowl from engine.

### 2 Installation

- d** - Lower top cowl into position over engine.
- e** - Rotate the rear latch counterclockwise to secure the rear cowl latch.
- f** - Pull out on front latching handle and push down on the front of the cowl to engage the front latch.

# MAINTENANCE

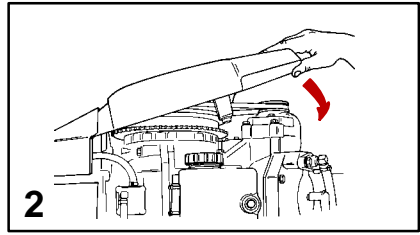
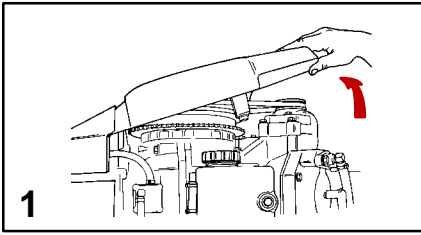

## Flywheel Cover Removal and Installation

### REMOVAL

- 1 Remove flywheel cover by lifting off.

### INSTALLATION

- 2 Install the flywheel cover two front pins into the front mounting holes and push the bottom mounting holes onto the rear pins.

## Fuel System

### **⚠ WARNING**

**Avoid serious injury or death from gasoline fire or explosion. Carefully follow all fuel system service instructions. Always stop the engine and DO NOT smoke or allow open flames or sparks in the area while servicing any part of the fuel system.**

### Before servicing any part of the fuel system:

- Stop engine and disconnect the battery.
- Drain the fuel system completely.
- Fuel system service must be performed in a well ventilated area.
- Inspect any completed service work for sign of fuel leakage.

**IMPORTANT: Use an approved container to collect and store fuel. Wipe up any spillage immediately. Material used to contain spillage must be disposed of in an approved receptacle.**

### FUEL LINE INSPECTION

Visually inspect the fuel line for cracks, swelling, leaks, hardness, or other signs of deterioration or damage. If any of these conditions are found, the fuel line must be replaced.

(continued on next page)

# MAINTENANCE

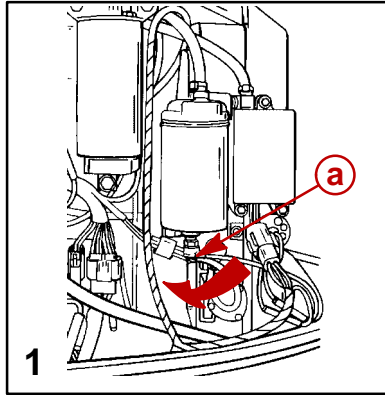

## Fuel System (Continued)

### WATER SEPARATING FUEL FILTER

**NOTE:** The warning system will turn on when water in the fuel filter reaches the full level. Refer to “Warning System” in Features & Controls Section.

- 1** This filter removes moisture and also debris from the fuel. If the filter becomes filled with water, the water can be removed. If the filter becomes plugged with debris, the filter must be replaced with a new filter.

#### Remove and replace filter as follows:

- Turn ignition key switch to OFF position.
- Disconnect wire (a) at bottom of filter. Remove filter by turning the filter in the direction of the arrow (clockwise). Tip the filter to drain fluid in a suitable container.
- Lubricate the sealing ring on the filter with oil. Thread on the filter and tighten securely by hand. Reconnect the wire to the filter.

**IMPORTANT:** Visually inspect for fuel leakage from the filter by squeezing the primer bulb until firm, forcing fuel into the filter.



# MAINTENANCE

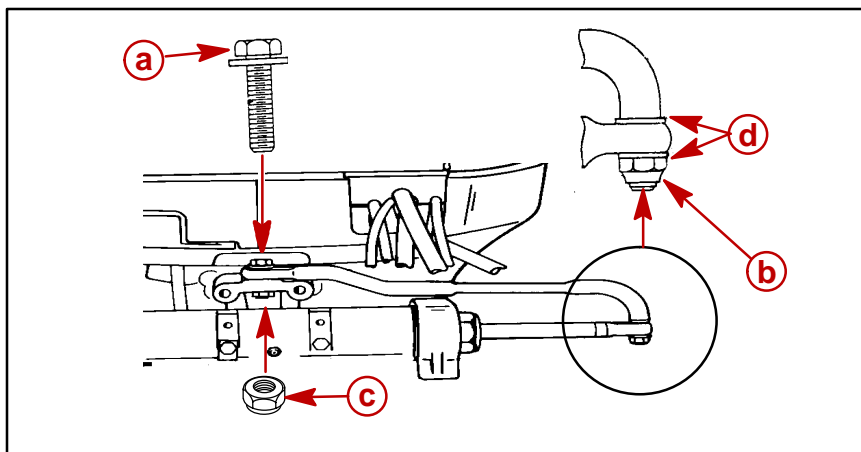

ohi1

## Steering Link Rod Fasteners

### DUAL CABLE STEERING

Installation instructions for dual cable single engine applications are included with the dual cable kit.

**IMPORTANT:** The steering link rod that connects the steering cables to the engine must be fastened using special washer head bolt (“a” – Part Number 10-849838) and self locking nylon insert locknuts (“b” & “c” – Part Number 11-34863). These locknuts must never be replaced with common nuts (non locking) as they will work loose/vibrate off freeing link rod to disengage.

### **⚠ WARNING**

Disengagement of a steering link rod can result in the boat taking a full, sudden, sharp turn. This potentially violent action can cause occupants to be thrown overboard exposing them to serious injury or death.

Assemble steering link rod to steering cable with two flat washers (d) and self locking nylon insert locknut (“b” – Part Number 11-34863). Tighten locknut (b) until it seats, then back nut off 1/4 turn.

Assemble steering link rod to engine with special washer head bolt (“a” – Part Number 10-849838) and self locking nylon insert locknut (“c” – Part Number 11-34863). First torque bolt (a) to 20 lb. ft. (27.1 N·m), then torque locknut (c) to 20 lb. ft. (27.1 N·m).

# MAINTENANCE

goh121

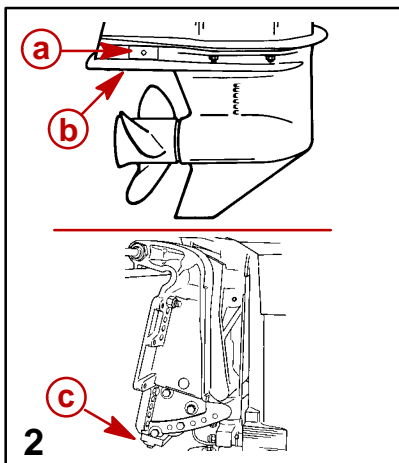
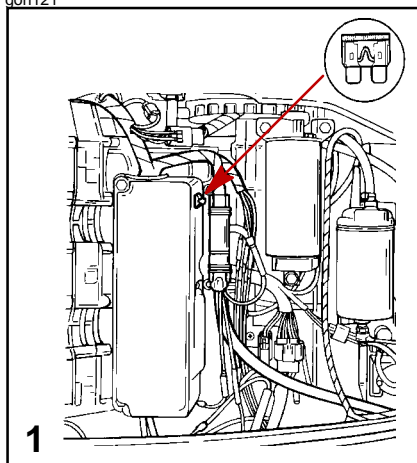

omh1

## Fuse Replacement

**IMPORTANT:** Always carry spare SFE 20 AMP fuses.

- 1 The electric starting circuit is protected from overload by an SFE 20 AMP fuse. If the fuse is blown, the electric starter motor will not operate. Try to locate and correct the cause of the overload. If the cause is not found, the fuse may blow again. Replace the fuse with a fuse of the same rating.

Replace with a new SFE 20 AMP fuse.

ohk12

## Corrosion Control Anodes

**IMPORTANT:** Anodes help protect the metal of the outboard from galvanic corrosion by sacrificing their metal to be slowly eroded instead of the outboard metals being eroded. All anodes require periodic inspection, especially in salt water. Replace any anodes before they are completely eroded. Never paint or apply protective coating on the anode as effectiveness of the anode will be reduced.

- 2 Your outboard has the following (four) corrosion control anodes.
  - a - Two bars, one in each side of the gear case housing above the anti-ventilation plate.
  - b - One plate installed under the anti-ventilation plate.
  - c - One bar across the bottom of the transom bracket assembly.

# MAINTENANCE

goh112

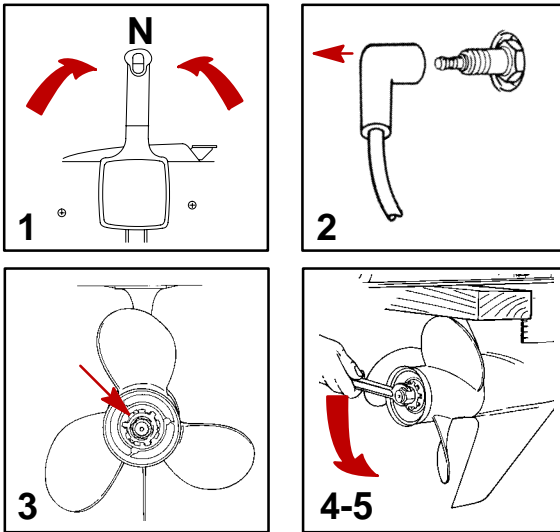

## Propeller Replacement

### **⚠ WARNING**

If the propeller is rotated while the engine is in gear, there is the possibility that the engine will crank over and start. To prevent this accidental engine starting and possible serious injury caused from being struck by a rotating propeller, always shift outboard to neutral position and remove spark plug leads before you service the propeller.

- 1** Shift outboard to neutral (N) position.
- 2** Remove spark plug leads to prevent engine from starting.
- 3** Straighten the bent tabs on the propeller nut retainer.
- 4** Place a block of wood between gear case and propeller to hold propeller and remove propeller nut.
- 5** If propeller is seized to the shaft and cannot be removed, consult an authorized dealer.

(continued on next page)

# MAINTENANCE

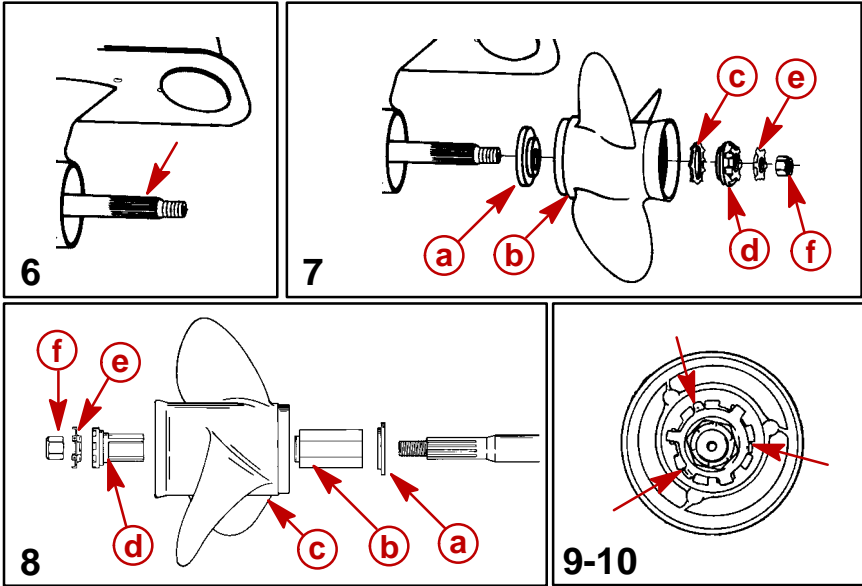

## Propeller Replacement (Continued)

- 6** Coat the propeller shaft with Mercury Precision Anti-Corrosion Grease or 2-4-C Marine Lubricant with Teflon.

**IMPORTANT:** To prevent the propeller hub from corroding and seizing to the propeller shaft, especially in salt water, always apply a coat of the recommended lubricant to the entire propeller shaft at the recommended maintenance intervals and also each time the propeller is removed.

- 7** Rubber Hub Propellers - Install thrust washer (a), propeller (b), continuity washer (c), splined washer (d), propeller nut retainer (e), and propeller nut (f) onto the shaft.
- 8** Replaceable Hub Propellers (Using Flo-Torq II Hub Assembly Kit P/N 835258A1 or 835258A2) - Install forward thrust hub (a), replaceable drive sleeve (b), propeller (c), drive sleeve adaptor (d), propeller nut retainer (e) and propeller nut (f) onto the shaft.
- 9** Place a block of wood between gear case and propeller and torque propeller nut to 55 lb. ft. (75 N·m).
- 10** Secure propeller nut by bending three of the tabs into the thrust hub grooves.

# MAINTENANCE

goh63

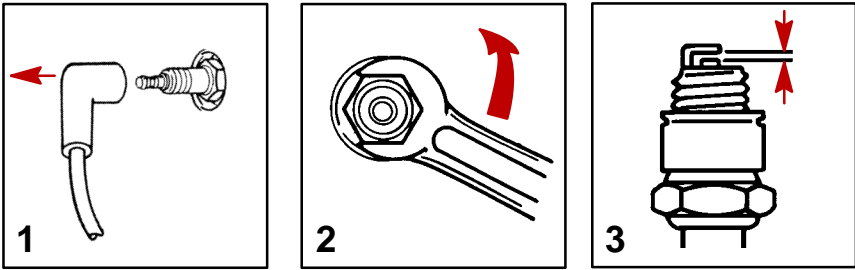

ohm4

## Spark Plug Inspection

Inspect spark plugs at the recommended intervals.

- 1 Remove the spark plug leads by twisting the rubber boots slightly and pull off. Inspect spark plug boots and replace if cracked.
- 2 Remove the spark plugs to inspect and clean. Replace spark plug if electrode is worn or the insulator is rough, cracked, broken, blistered, or fouled.
- 3 Set the spark plug gap. See Specification Chart in General Information Section.
- 4 Before reinstalling spark plugs, clean away dirt on the spark plug seats. Install plugs finger tight, and tighten 1/4 turn or torque to 20 lb. ft. (27 N·m).

## Battery Inspection

The battery should be periodically inspected.

**IMPORTANT: Read the safety and maintenance instructions which accompany your battery.**

1. Turn off the engine before servicing the battery.
2. Add water as necessary to keep the battery full.
3. Make sure the battery is secure.
4. Battery cable terminals should be clean, tight, and positive to positive and negative to negative.
5. Make sure the battery is equipped with nonconductive terminal shields to prevent accidental shorting of battery terminals.

# MAINTENANCE

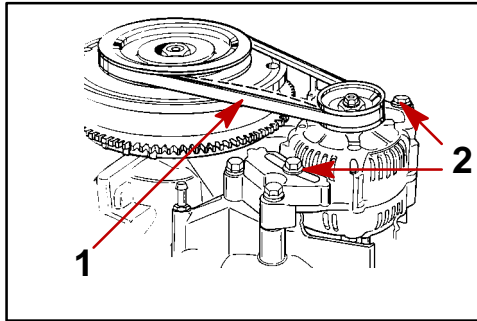

omk1

## Alternator Drive Belt Tension Adjustment

The drive belt should be periodically inspected for condition and tension.

- 1** Check belt tension by pressing in on the belt at the point shown. Proper tension allows the belt to be pressed in 1/2 in. (12.7mm).
- 2** If adjustment is required, loosen bolts and adjust belt. Re-torque adjustment bolts to 40 lb. ft. (55 N·m).

# MAINTENANCE

goh124

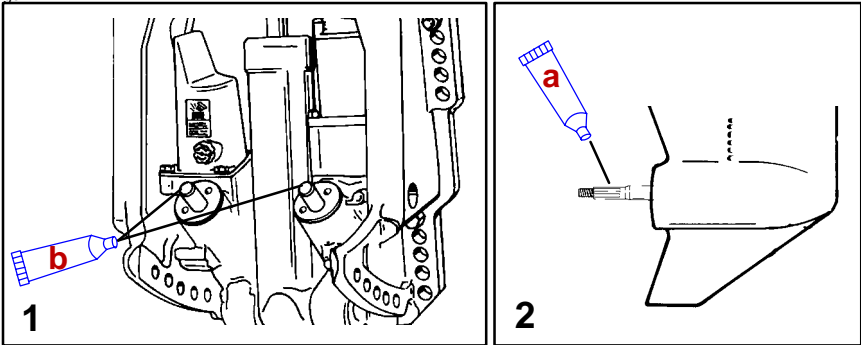

oho41

## Lubrication Points

- a** - Mercury Precision Anti-Corrosion Grease (92-802867A1)
- b** - Mercury Precision 2-4-C w/Teflon (92-802859A1) or Mercury Precision Special Lubricant 101 (92-802865A1)

- 1 (Fleet Master and Torque Master Models Only.)** Trim Rod Ball Ends – Turn the ball ends to work the lubricant into the ball sockets.
- 2** Propeller Shaft – Refer to Propeller Replacement for removal and installation of the propeller. Coat the entire propeller shaft with lubricant to prevent the propeller hub from corroding and seizing to the shaft.

(continued on next page)

# MAINTENANCE

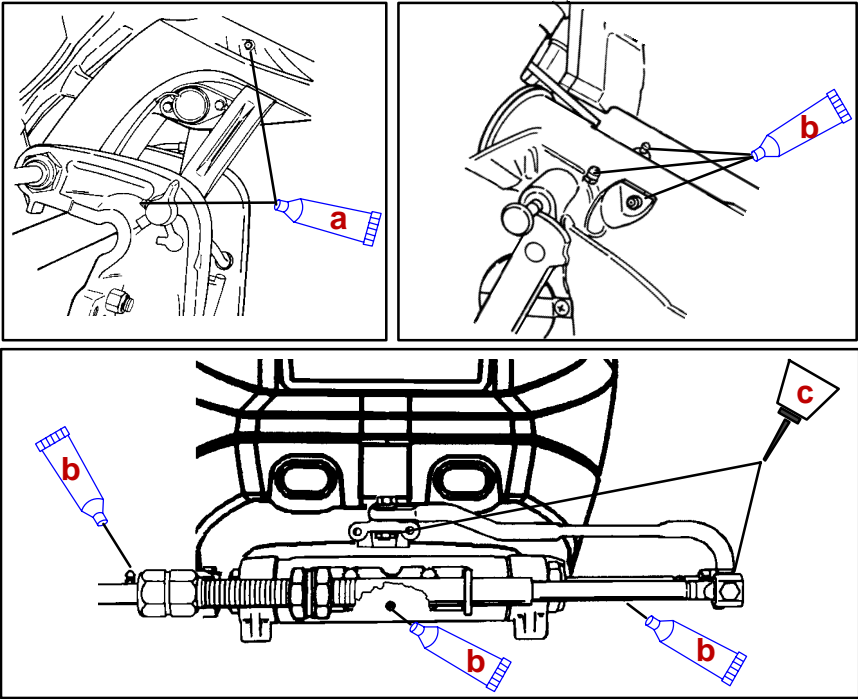

## Lubrication Points (continued)

- a** - Mercury Precision Anti-Corrosion Grease (92-802867A1)
- b** - Mercury Precision 2-4-C w/Teflon (92-802859A1) or Mercury Precision Special Lubricant 101 (92-802865A1)
- c** - Light Weight Oil

**NOTE:** Propeller Shaft – Refer to Propeller Replacement for removal and installation.

### **⚠ WARNING**

The end of the steering cable must be fully retracted into the outboard tilt tube before adding lubricant thru grease fitting. Adding lubricant to steering cable when fully extended could cause steering cable to become hydraulically locked. An hydraulically locked steering cable could cause loss of steering control, possibly resulting in serious injury or death.



# MAINTENANCE

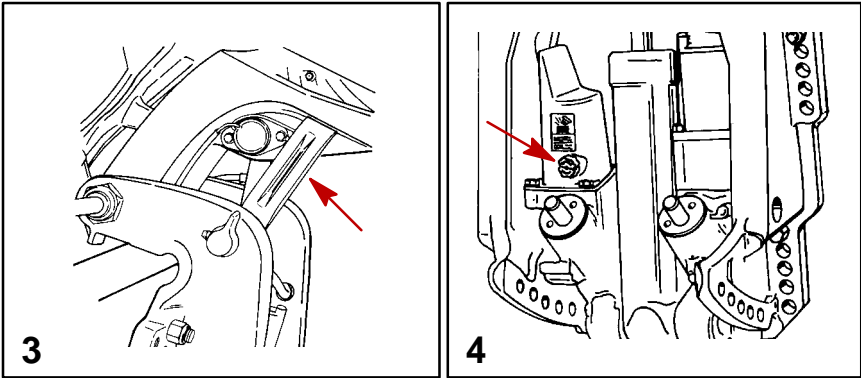

## Checking Power Trim Fluid

### FLEET MASTER AND TORQUE MASTER MODELS

- 3** Tilt outboard to the full up position and engage the tilt support lock.
- 4** Remove fill cap and check fluid level. The fluid level should be even with the bottom of the fill hole. Add Mercury Precision Power Trim & Steering Fluid. (92-802880A1) If not available, use automotive (ATF) automatic transmission fluid.

(continued on next page)

# MAINTENANCE

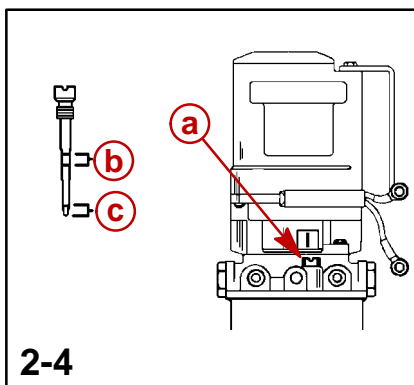
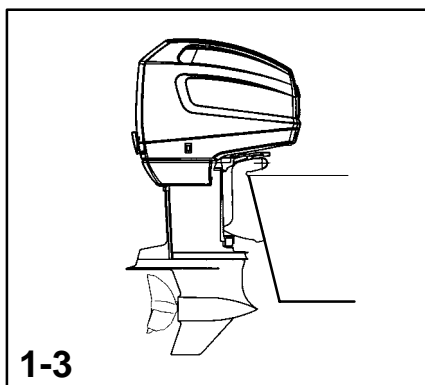

## Checking Power Trim Fluid (continued)

### SPORT MASTER MODELS

- 1 Place outboard in the full down (in) position.
- 2 Remove trim pump fill/vent screw (a)
  - Wipe fill/vent screw with a clean, lint-free cloth and reinstall - DO NOT THREAD INTO PUMP.
  - Remove fill/vent screw and note oil level. Oil level must be between the “ADD” (c) and “FULL” (b) marks on dipstick.
  - If necessary, add Mercury Precision Power Trim & Steering Fluid (92-802880A1) or SAE 10W-30 or 10W-40 motor oil thru the fill/vent screw hole to bring level up to the “FULL” mark on the dipstick. DO NOT OVERFILL.
- 3 To purge system of air, raise the outboard 2 or 3 times. Recheck oil level and add oil if necessary.
- 4 Reinstall fill/vent screw by turning it all-the-way in, then back it out one and a half (1-1/2) turns.

### **⚠ CAUTION**

**Fill/Vent screw MUST BE backed out one and a half (1-1/2) turns (after bottoming out) to vent pump reservoir. FAILURE TO BACK SCREW OUT COULD RESULT IN DAMAGE TO PUMP.**

# MAINTENANCE

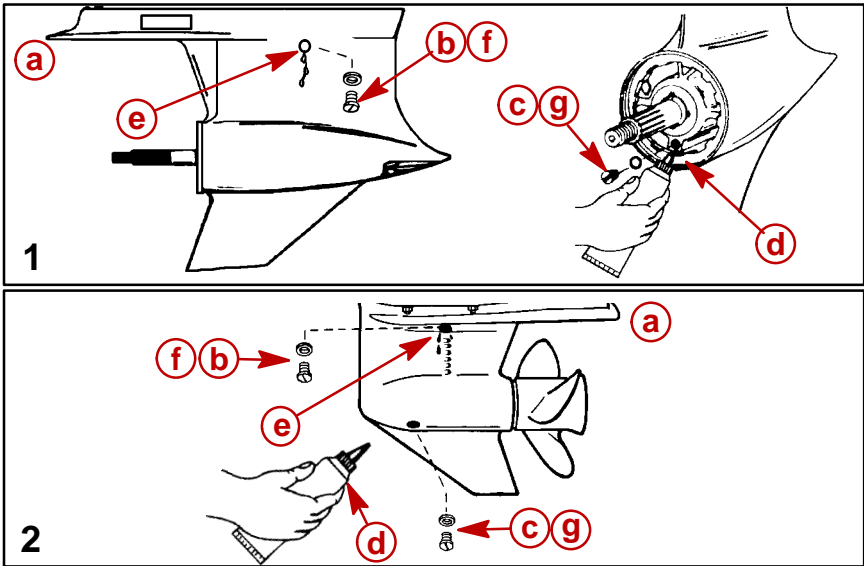

## Gear Case Lubricant

### Checking Gear Case Lubricant / Refilling Gear Case

#### 1 Torquemaster and Sportmaster

#### 2 Fleetmaster

- a** - Place outboard in a vertical operating position.
- b** - Remove the (upper) vent plug and sealing washer.
- c** - Remove the (lower) Fill/Drain plug.

**NOTE:** Examine the magnetic fill/drain plug for metal particles. A small amount of metal filings or fine metal particles indicates normal gear wear. An excessive amount of metal filings or larger particles (chips) should be checked by an authorized dealer.

- d** - Quickly place lubricant tube into the fill hole.
- e** - Slowly add lubricant until it flows from the (upper) vent hole.

**IMPORTANT: Replace sealing washers if damaged.**

- f** - Stop adding lubricant. Install the (upper) vent plug and sealing washer before removing the lubricant tube.
- g** - Remove lubricant tube and reinstall cleaned (lower) fill/drain plug and sealing washer.

(continued on next page)

# MAINTENANCE

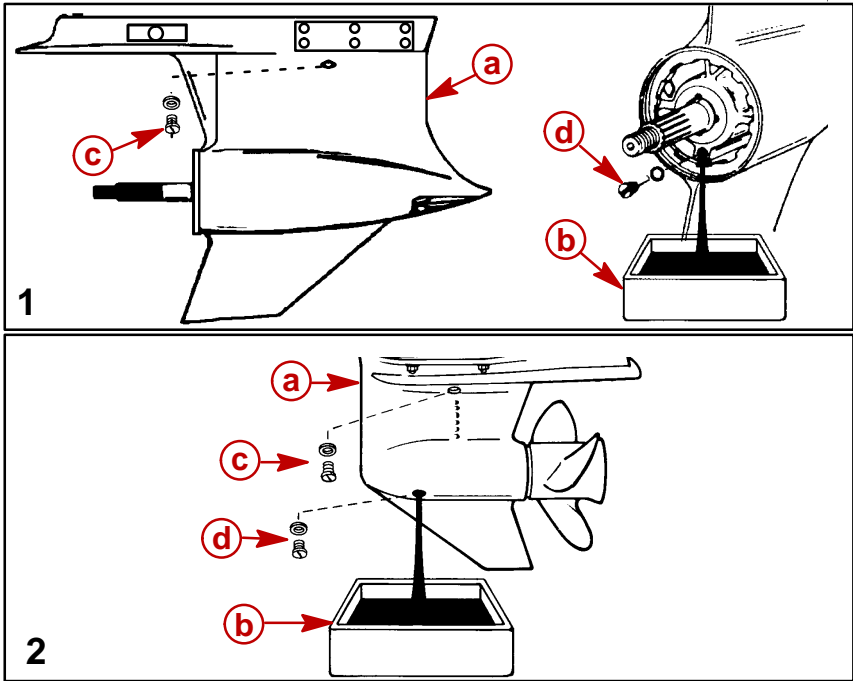

## Gear Case Lubricant (Continued)

### Water in Gear Lubricant May:

- Settle to bottom and drain out with the lubricant.
- Be mixed with lubricant giving a milky color to lubricant.

### Water in Gear Lubricant Will:

- Result in premature bearing failure.
- In freezing temperatures, turn to ice and damage gearcase.

### Draining Gear Case

#### 1 Torquemaster/Sportmaster

#### 2 Fleetmaster

- a** - Place outboard in a vertical operating position.
- b** - Place drain pan below outboard.
- c** - Remove (upper) vent plug and sealing ring.
- d** - Remove (lower) fill/drain plug/sealing ring, drain lubricant.

### GEAR CASE LUBRICANT CAPACITY

Gear case lubricant capacity is approximately 22.5 fl. oz. (666 ml).

# STORAGE

oia2

## Storage Preparation

The major consideration in preparing your outboard for storage is to protect it from rust, corrosion, and freezing water damage.

The following storage procedures should be followed to prepare your outboard for out of season storage or prolonged storage (two months or longer).

## Positioning Outboard for Storage

Store outboard in an upright (vertical) position to allow water to drain out of outboard.

### CAUTION

**If outboard is stored tilted up in freezing temperature, water may enter the propeller exhaust outlet in the gear case and could freeze causing damage to the outboard.**

oib11

## Fuel system

**IMPORTANT: Gasoline containing alcohol (ethanol or methanol) can cause a formation of acid during storage and can damage the fuel system. If the gasoline being used contains alcohol, it is advisable to drain as much of the remaining gasoline as possible from the fuel tank, remote fuel line, and engine fuel system.**

To prevent varnish or gum buildup during extended storage, we recommend adding Mercury Precision Fuel System Treatment and Stabilizer (92-802875A1) to the fuel tank and operation of the engine to introduce the additives to the system.

# STORAGE

## Fuel System (Continued)

1. Portable Fuel Tank – Pour the required amount of Mercury Precision Fuel System Treatment and Stabilizer (92-802875A1) (follow instructions on container) into fuel tank. Tip fuel tank back and forth to mix stabilizer with the fuel.
2. Permanently Installed Fuel Tank – Pour the required amount of Mercury Precision Fuel System Treatment and Stabilizer (92-802875A1) (follow instructions on container) into a separate container and mix with approximately one quart (one liter) of gasoline. Pour this mixture into fuel tank.

### CAUTION

**Prevent damage to the water pump or overheating of the engine, never start or run your outboard (even momentarily) without an adequate water supply to the engine.**

3. Place the outboard in water or connect flushing attachment for circulating cooling water. Run the engine for ten minutes to allow treated fuel to fill the fuel system.

hid1

## Protecting Internal Engine Components

**NOTE:** Before performing the following steps, make sure the fuel system has been prepared for storage. Refer to Fuel System.

1. Remove the spark plugs and inject a five second spray of Mercury Precision Storage Seal Rust Inhibitor (92-802878-56) around the inside of each cylinder.
2. Rotate the flywheel manually several times to distribute the storage seal in the cylinders. Reinstall spark plugs.
3. Remove the water separating fuel filter and empty contents in a suitable container. Refer to Maintenance Section for removal and installation of filter. Replace fuel filter annually, or every 100 hours of operation, or if large amount of fuel contamination is present.

# STORAGE

oic7

## Protecting External Outboard Components

1. Lubricate all outboard components listed in the Inspection and Maintenance Schedule.
2. Touch up any paint nicks. See dealer for touch-up paint.
3. Spray Mercury Precision Corrosion Guard (92-802878-55) on external metal surfaces, (Do not apply on corrosion control anodes).

oie1

## Gear Case

1. Drain and refill the gear case lubricant (refer to maintenance procedure).

## BATTERY STORAGE

1. Follow the battery manufacturers instructions for storage and recharging.
2. Remove the battery from the boat and check water level. Recharge if necessary.
3. Store the battery in a cool, dry place.
4. Periodically check the water level and recharge the battery during storage.

# TROUBLESHOOTING

## **1 – STARTER MOTOR WILL NOT CRANK THE ENGINE**

### **POSSIBLE CAUSES**

- Blown 20 Amp fuse in the starting circuit. Refer to Maintenance Section.
- Outboard is not shifted to neutral position.
- Weak battery or battery connections are loose or corroded.
- Ignition key switch failure.
- Wiring or electrical connection faulty.
- Starter motor or starter solenoid failure.

## **2 – ENGINE WILL NOT START**

### **POSSIBLE CAUSES**

- Lanyard stop switch not in RUN position.
- Incorrect starting procedure. Refer to Operating Section.
- Old or contaminated gasoline.
- Engine flooded. Refer to Operating Section.
- Fuel is not reaching the engine.
  - a. Fuel tank is empty.
  - b. Fuel tank vent not open or restricted.
  - c. Fuel line is disconnected or kinked.
  - d. Fuel filter is obstructed. Refer to Maintenance Section.
  - e. Fuel pump failure.
  - f. Fuel tank filter obstructed.
- Ignition system component failure.
- Spark plugs fouled or defective. Refer to Maintenance Section.



# TROUBLESHOOTING

## 3 – ENGINE RUNS ERRATICALLY

### POSSIBLE CAUSES

- Spark plugs fouled or defective. Refer to Maintenance Section.
- Incorrect setup and adjustments.
- Fuel is being restricted to the engine.
  - a. Fuel injectors obstructed.
  - b. Fuel tank filter obstructed.
  - c. Water separating filter or In-Line filter clogged.
  - d. Stuck anti-siphon valve on built in fuel tank.
  - e. Fuel line is kinked or pinched.
  - f. Reed valve open or broken.
- Fuel pump failure.
- Ignition system component failure.

## 4 – PERFORMANCE LOSS

### POSSIBLE CAUSES

- Throttle not opening fully.
- Damaged or improper size propeller.
- Incorrect engine timing, adjustments, or setup.
- Boat overloaded or load improperly distributed.
- Excessive water in bilge.
- Boat bottom is dirty or damaged.

# **TROUBLESHOOTING**

## **5 – BATTERY WILL NOT HOLD CHARGE**

### **POSSIBLE CAUSES**

- Battery connections are loose or corroded.
- Low electrolyte level in battery.
- Inefficient battery.
- Excessive use of electrical accessories.
- Defective alternator, or voltage regulator.

## **6 – ENGINE OVERHEATING (CONTINUOUS HORN SOUND)**

### **POSSIBLE CAUSES**

- Cooling system clogged
- Engine overloaded (cannot attain recommended RPM)
- Incorrect ignition timing
- Incorrect transom height (water pickups not getting adequate water supply)
- Not enough oil in fuel mixture
- Lean fuel mixture

# NOTES

# ENGINE WIRING DIAGRAM

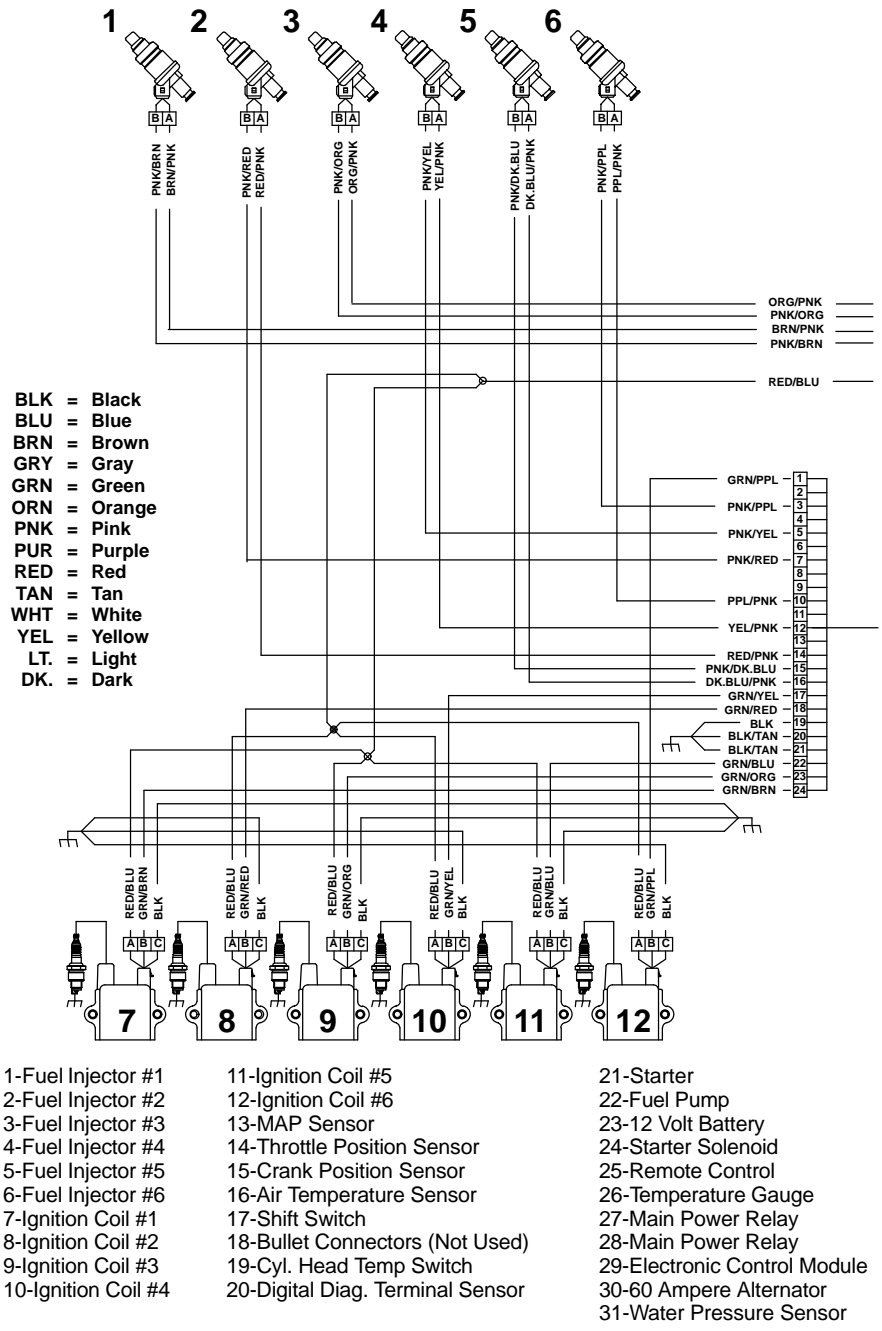

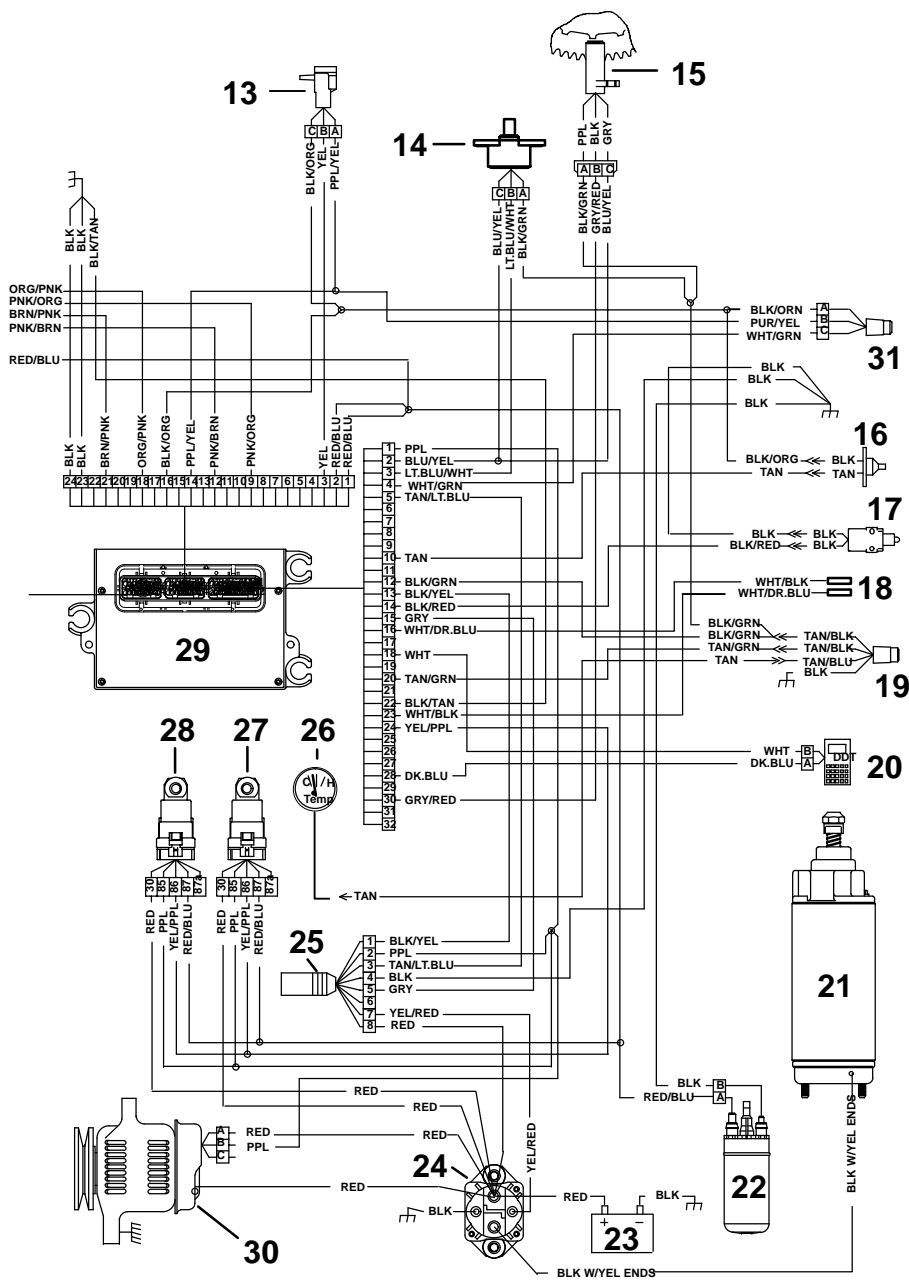

# MAINTENANCE LOG

Record here all maintenance performed on your outboard. Be sure to save all work orders and receipts.

Date	Maintenance Performed	Engine Hours

# MAINTENANCE LOG

<b>Date</b>	<b>Maintenance Performed</b>	<b>Engine Hours</b>