

If the outboard motor's serial number plate contains the CE mark in the lower left-hand corner, the following statement applies:

This outboard motor manufactured by Mercury Marine, Fond du Lac, WI, USA or Marine Power Europe Inc. Park Industriel, de Petit-Rechain, Belgium complies with the requirements of the following directives and standards, as amended:

Recreational Craft Directive: 94/25/EC; std. ISO 8665, ISO 11547

Machinery Directive: 98/37/EC,

EMC Directive: 89/336/EC; std. EN50081-1, SAE J551 (CISPR Pub. 12), EN 50082-1, IEC 61000 PT4-2, IEC 61000 PT4-3



Patrick C. Mackey

President, Mercury Marine, Fond du Lac, WI USA

European Regulations Contact:

Product Environmental Engineering Department, Mercury Marine,  
Fond du Lac, WI USA

## EPA Emissions Regulations

Outboards manufactured by Mercury Marine in the United States are certified to the United States Environmental Protection Agency as conforming to the requirements of the regulations for the control of air pollution from new outboard motors. This certification is contingent on certain adjustments being set to factory standards. For this reason, the factory procedure for servicing the product must be strictly followed and, wherever practicable, returned to the original intent of the design.

**Maintenance, replacement, or repair of the emission control devices and systems may be performed by any marine engine repair establishment or individual.**

Engines are labeled with an Emission Control Information decal as permanent evidence of EPA certification.

### WARNING

The engine exhaust from this product contains chemicals known to the state of California to cause cancer, birth defects or other reproductive harm.

## Thank You

for your purchase of one of the finest outboards available. You have made a sound investment in boating pleasure. Your outboard has been manufactured by Mercury Marine, a world leader in marine technology and outboard manufacturing since 1939. These years of experience have been committed to the goal of producing the finest quality products. This led to Mercury Marine's reputation for strict quality control, excellence, durability, lasting performance and being the best at providing after the sale support.

Please read this manual carefully before operating your outboard. This manual has been prepared to assist you in the operation, safe use and care of your outboard.

All of us at Mercury Marine took pride in building your outboard and wish you many years of happy and safe boating.

Again, thank you for your confidence in Mercury Marine.

## Warranty Message

The product you have purchased comes with a **limited warranty** from Mercury Marine, the terms of the warranty are set forth in the **Warranty Information** Section of this manual. The warranty statement contains a description of what is covered, what is not covered, the duration of coverage, how to best obtain warranty coverage, **important disclaimers and limitations of damages**, and other related information. Please review this important information.

The description and specifications contained herein were in effect at the time this manual was approved for printing. Mercury Marine, whose policy is one of continued improvement, reserves the right to discontinue models at any time, to change specifications, designs, methods, or procedures without notice and without incurring obligation.

Mercury Marine, Fond du Lac, Wisconsin U.S.A.

Litho in U.S.A.

© 2005, Mercury Marine

Mercury, Mercury Marine, MerCruiser, Mercury MerCruiser, Mercury Racing, Mercury Precision Parts, Mercury Propellers, Mariner, Quicksilver, #1 On The Water, Alpha, Bravo, Pro Max, OptiMax, Sport-Jet, K-Planes, MerCathode, RideGuide, SmartCraft, Zero Effort, M with Waves logo, Mercury with Waves logo, and SmartCraft logo are all registered trademarks of Brunswick Corporation. Mercury Product Protection logo is a registered service mark of Brunswick Corporation.

## **Mercury Premier Service**

Mercury evaluates the service performance of its dealers and assigns its highest rating of "Mercury Premier" to those demonstrating an exceptional commitment to service.

### **Earning a Mercury Premier Service rating means a dealer:**

- Achieves a high 12 month service CSI (Customer Satisfaction Index) score for warranty service.
- Possesses all necessary service tools, test equipment, manuals and parts books.
- Employs at least one Certified or Master technician.
- Provides timely service for all Mercury Marine customers.
- Offers extended service hours and mobile service, when appropriate.
- Uses, displays and stocks adequate inventory of genuine Mercury Precision Parts.
- Offers a clean, neat shop with well organized tools and service literature.



# TABLE OF CONTENTS

---

## Warranty Information

---

Warranty Registration United States And Canada.....	1
Mercury Racing Demonstrator Policy.....	1
Transfer Of Warranty.....	2
Mercury Racing Division 2 Year Limited Warranty (OptiMax XS Series Outboards).....	2
Mercury Racing Division 3 Year Limited Warranty Against Corrosion Failure (Applicable Only to the United States, Canada and Australia).....	5
Warranty Coverage and Exclusions for Mercury Racing Outboard and Sterndrive Products.....	8
California Emissions Limited Warranty.....	9
Star Label.....	14

---

## General Information

---

Boater's Responsibilities.....	15
Before Operating Your Outboard.....	15
Boat Horsepower Capacity.....	15
High-Speed And High-Performance Boat Operation.....	16
Outboard Remote Control Models .....	16
Remote Steering Notice.....	17
Lanyard Stop Switch.....	18
Protecting People In The Water.....	19
Exhaust Emissions.....	20
Passenger Safety Message - Pontoon Boats And Deck Boats.....	21
Wave And Wake Jumping.....	23
Impact With Underwater Hazards.....	24
Selecting Accessories For Your Outboard.....	25
Safe Boating Suggestions.....	25
Recording Serial Number.....	27
Specifications - 225 Sport XS.....	27
Special Tools and Kits.....	28
Component Identification.....	29
Propeller Selection.....	29

---

## Transporting

---

Trailer Boat/Outboard .....	31
-----------------------------	----

# TABLE OF CONTENTS

---

## Fuel and Oil

---

Avoiding Fuel Flow Restrictions.....	32
Fuel Requirements.....	32
Oil Recommendation.....	33
Filling Remote Oil Tank.....	34
Filling Engine Mounted Oil Reservoir Tank.....	34
Filling Fuel Tank.....	35

---

## Features and Controls

---

Remote Control Features.....	36
Zero Effort Control Features.....	37
Warning System.....	37
Overspeed Rev Limit.....	40
Power Trim And Tilt.....	40
Power Trim Operation .....	41
Power Tilt Operation (Three-Ram Trim Systems).....	43
Auxiliary Tilt Switch.....	44
Manual Tilt Operation.....	44

---

## Operation

---

Engine Break-in.....	46
Engine Break-in Fuel Mixture.....	46
Pre-Starting Check List.....	46
Operating In Freezing Temperatures.....	47
Operating In Salt Water Or Polluted Water.....	47
Operating at High Elevations.....	47
Effects of Elevation and Weather on Performance.....	48
Setting Trim Angle While Running Engine at Idle Speed.....	49
Operating in Shallow Water.....	49
Starting The Engine.....	50
Gear Shifting.....	53
Stopping The Engine.....	53

---

## Maintenance

---

Power Package Care.....	54
Submerged Power Package.....	54

# TABLE OF CONTENTS

Replacement Parts for Your Power Package.....	54
EPA Emissions Regulations.....	54
Inspection And Maintenance Schedule.....	55
Flushing the Cooling System (Powerhead).....	57
Flushing the Cooling System (Lower Unit).....	58
Top Cowl Removal and Installation.....	59
Cleaning Care for Top Cowl.....	59
Fuel System.....	60
Steering Link Rod Fasteners.....	62
Fuses .....	64
Corrosion Control Anode.....	65
Spark Plug Inspection and Replacement.....	66
Battery Inspection .....	67
Charging System Fusible Link.....	68
Removing the Propeller.....	68
Installing the Propeller (19 Spline Shafts).....	69
Lubrication Points.....	72
Checking Trim System Fluid Level.....	73
Gearcase Lubricant.....	75

---

## Storage

---

Storage Preparation.....	77
Protecting Internal Engine Components.....	79
Protecting External Outboard Components.....	79
Gearcase.....	79
Positioning Outboard For Storage.....	80
Battery Storage.....	80

---

## Troubleshooting

---

Starter Motor Will Not Crank the Engine.....	81
Engine Will Not Start.....	81
Engine Runs Erratically.....	81
Performance Loss.....	82
Warning Horn Activates (With Power Loss).....	82
Warning Horn Activates (No Power Loss).....	83
Battery Will Not Hold Charge.....	83

# TABLE OF CONTENTS

---

## Owner Service Assistance

---

Local Repair Service.....	84
Service Away From Home.....	84
Parts And Accessories Inquiries.....	84
Service Assistance.....	84
Mercury Marine Service Offices.....	85
Ordering Literature.....	86

---

## Maintenance Log

---

Maintenance Log.....	87
----------------------	----



# WARRANTY INFORMATION

## Warranty Registration United States And Canada

*Outside United States and Canada - Check with your local distributor.*

1. You may change your address at any time, including at time of warranty claim, by calling Mercury Marine or sending a letter or fax with your name, old address, new address, and engine serial number to Mercury Marine's warranty registration department. Your dealer can also process this change of information.

Mercury Marine

Attn.: Warranty Registration Department

W6250 W. Pioneer Road

P.O. Box 1939

Fond du Lac, WI 54936-1939

920-929-5054

Fax 920-929-5893

**NOTE:** *Registration lists must be maintained by Mercury Marine and any dealer on marine products sold in the United States, should a safety recall notification under the Federal Safety Act be required.*

2. At the time of sale, the dealer should complete the warranty registration and immediately submit it to Mercury Marine via MercNET, E-mail, or mail. Upon receipt of this warranty registration, Mercury Marine will record the registration.

**IMPORTANT:** **Your warranty coverage begins at the time of sale, but warranty claims cannot be processed until the product is registered with Mercury Marine.**

3. Upon processing the warranty registration, Mercury Marine will send the purchaser a Mercury Owner Resource Guide. The back page of this guide contains your warranty registration information and should be saved. If this registration verification is not received within 30 days, please contact your selling dealer immediately.

## Mercury Racing Demonstrator Policy

Mercury Racing products used by a dealer, boat builder, their representatives or agents for personal, recreational or promotional purposes, or products that accumulate more than 10 hours of demonstration run time **MUST BE REGISTERED** as a demonstrator by the dealer, boat builder or person(s) using those products. The "Date of Sale" will be the date the product was first put into service.

Warranty coverage can be transferred to the retail customer by contacting Mercury Racing Technical Service. The retail purchaser of these products **MUST** be informed that the product was previously used and registered as a demonstrator along with the actual run time on the product.

# WARRANTY INFORMATION

## Transfer Of Warranty

The limited warranty is transferable to a subsequent purchaser, but only for the remainder of the unused portion of the limited warranty. This will not apply to products used for commercial applications.

To transfer the warranty to the subsequent owner, send or fax a copy of the bill of sale or purchase agreement, new owner's name, address and engine serial number to Mercury Marine's warranty registration department. In the United States and Canada, mail to:

Mercury Marine  
Attn: Warranty Registration Department  
W6250 W. Pioneer Road  
P.O. Box 1939  
Fond du Lac, WI 54936-1939  
920-929-5054  
Fax 920-929-5893

Upon processing the transfer of warranty, Mercury Marine will send registration verification to the new owner of the product by mail.

There is no charge for this service.

For products purchased outside the United States and Canada, contact the distributor in your country, or the Marine Power Service Center closest to you.

## Mercury Racing Division 2 Year Limited Warranty (OptiMax XS Series Outboards)

### WHAT IS COVERED

Mercury Marine warrants its new OptiMax XS series Outboard products (and remanufactured OptiMax XS series Outboard products sold under the trade name "Pacemaker") to be free of defects in material and workmanship during the period described below.

### DURATION OF COVERAGE

This Limited Warranty provides coverage for two (2) years from either the date the product is first sold to a recreational use retail purchaser, or the date on which the product is first put into service, whichever occurs first. The repair or replacement of parts, or the performance of service under this warranty, does not extend the life of this warranty beyond its original expiration date. Unexpired warranty coverage can be transferred to a subsequent purchaser upon proper re-registration of the product.

# **WARRANTY INFORMATION**

## **CONDITIONS THAT MUST BE MET IN ORDER TO OBTAIN WARRANTY COVERAGE**

Warranty coverage is available only to retail customers that purchase from a Dealer authorized by Mercury Marine to distribute the product in the country in which the sale occurred, and then only after the Mercury Marine specified pre-delivery inspection process is completed and documented. Warranty coverage becomes available upon proper registration of the product by the authorized dealer. Inaccurate warranty registration information regarding recreational use, or subsequent change of use from recreational to commercial may void the warranty at the sole discretion of Mercury Marine. Routine maintenance outlined in the Operation and Maintenance Manual must be timely performed in order to maintain warranty coverage. Mercury Marine reserves the right to make warranty coverage contingent upon proof of proper maintenance.

## **WHAT MERCURY WILL DO**

Mercury's sole and exclusive obligation under this warranty is limited to, at our option, repairing a defective part, replacing such part or parts with new or Mercury Marine certified re-manufactured parts, or refunding the purchase price of the Mercury product. Mercury reserves the right to improve or modify products from time to time without assuming an obligation to modify products previously manufactured.

## **HOW TO OBTAIN WARRANTY COVERAGE**

The customer must provide Mercury with a reasonable opportunity to repair and reasonable access to the product for warranty service. Warranty claims shall be made by delivering the product for inspection to a Mercury dealer authorized to service the product. If purchaser cannot deliver the product to such a dealer, written notice must be given to Mercury. We will then arrange for the inspection and any covered repair. Purchaser in that case shall pay for all related transportation charges and/or travel time. If the service provided is not covered by this warranty, purchaser shall pay for all related labor and material, and any other expenses associated with that service. Purchaser shall not, unless requested by Mercury, ship the product or parts of the product directly to Mercury. The warranty registration card is the only valid registration identification and must be presented to the dealer at the time warranty service is requested in order to obtain coverage.

# WARRANTY INFORMATION

## WHAT IS NOT COVERED

This limited warranty does not cover routine maintenance items, tune ups, adjustments, normal wear and tear, damage caused by abuse, abnormal use, use of a propeller or gear ratio that does not allow the engine to run in its recommended wide-open-throttle rpm range (refer to the **Operation and Maintenance Manual**), operation of the product in a manner inconsistent with the recommended operation/duty cycle section of the **Operation and Maintenance Manual**, neglect, accident, submersion, improper installation (proper installation specifications and techniques are set forth in the installation instructions for the product), improper service, use of an accessory or part not manufactured or sold by us, operation with fuels, oils or lubricants which are not suitable for use with the product (Refer to the **Operation and Maintenance Manual**), alteration or removal of parts, water entering the engine through the fuel intake, air intake or exhaust system, or damage to the product from insufficient cooling water caused by blockage of the cooling system by a foreign body, running the engine out of water, mounting the engine too high on the transom, or running the boat with the engine trimmed out too far. The commercial use of the product, defined as any work or employment related use of the product, or any income generating use of the product, even if such use is only occasional, will void the warranty. Use of the product for racing or other competitive activity, at any point, even by a prior owner of the product, voids the warranty. Expenses related to haul-out, launch, towing, storage, telephone, rental, inconvenience, slip fees, insurance coverage, loan payments, loss of time, loss of income, tournament fees, club fees, prize money or any other type of incidental or consequential damages are not covered by this warranty. Also, expenses associated with the removal and/or replacement of boat partitions or material caused by boat design for access to the product are not covered by this warranty.

No individual or entity, including Mercury Marine authorized dealers, has been given authority by Mercury Marine to make any affirmation, representation or warranty regarding the product, other than those contained in this limited warranty, and if made, shall not be enforceable against Mercury Marine.

For additional information regarding events and circumstances covered by this warranty, and those that are not, refer to the **Warranty Coverage** section of the **Operation and Maintenance Manual**, incorporated by reference into this warranty.

# WARRANTY INFORMATION

**DISCLAIMERS AND LIMITATIONS: THE IMPLIED WARRANTIES OF MERCHANTABILITY AND FITNESS FOR A PARTICULAR PURPOSE ARE EXPRESSLY DISCLAIMED. TO THE EXTENT THAT THEY CANNOT BE DISCLAIMED, THE IMPLIED WARRANTIES ARE LIMITED IN DURATION TO THE LIFE OF THE EXPRESS WARRANTY. INCIDENTAL AND CONSEQUENTIAL DAMAGES ARE EXCLUDED FROM COVERAGE UNDER THIS WARRANTY. SOME STATES/COUNTRIES DO NOT ALLOW FOR THE DISCLAIMERS, LIMITATIONS AND EXCLUSIONS IDENTIFIED ABOVE, AS A RESULT, THEY MAY NOT APPLY TO YOU. THIS WARRANTY GIVES YOU SPECIFIC LEGAL RIGHTS, AND YOU MAY ALSO HAVE OTHER LEGAL RIGHTS WHICH VARY FROM STATE TO STATE AND COUNTRY TO COUNTRY.**

## **Mercury Racing Division 3 Year Limited Warranty Against Corrosion Failure (Applicable Only to the United States, Canada and Australia)**

### **WHAT IS COVERED**

We warrant each new Mercury, Mariner, Mercury Racing, Sport Jet, M2 Jet Drive, Tracker by Mercury Marine Outboard, MerCruiser Inboard or sterndrive engine (Product) rendered inoperative as a direct result of corrosion for the period of time described below.

### **DURATION OF COVERAGE**

This limited corrosion warranty provides coverage for three (3) years from either the date the product is first sold, or the date on which the product is first put into service, whichever occurs first. The repair or replacement of parts, or the performance of service under this warranty does not extend the life of this warranty beyond its original expiration date. Unexpired warranty coverage can be transferred to subsequent (noncommercial use) purchaser upon proper re-registration of the product.

# **WARRANTY INFORMATION**

## **CONDITIONS THAT MUST BE MET IN ORDER TO OBTAIN WARRANTY COVERAGE**

Warranty coverage is available only to retail customers that purchase from a Dealer authorized by Mercury Marine to distribute the product in the country in which the sale occurred, and then only after the Mercury Marine specified pre-delivery inspection process is completed and documented. Warranty coverage becomes available upon proper registration of the product by the authorized dealer. Corrosion prevention devices specified in the Operation and Maintenance Manual must be in use on the boat, and routine maintenance outlined in the Operation and Maintenance Manual must be timely performed (including without limitation the replacement of sacrificial anodes, use of specified lubricants, and touch-up of nicks and scratches) in order to maintain warranty coverage. Mercury Marine reserves the right to make warranty coverage contingent upon proof of proper maintenance.

## **WHAT MERCURY WILL DO**

Mercury's sole and exclusive obligation under this warranty is limited to, at our option, repairing a corroded part, replacing such part or parts with new or Mercury Marine certified re-manufactured parts, or refunding the purchase price of the Mercury product. Mercury reserves the right to improve or modify products from time to time without assuming an obligation to modify products previously manufactured.

## **HOW TO OBTAIN WARRANTY COVERAGE**

The customer must provide Mercury with a reasonable opportunity to repair, and reasonable access to the product for warranty service. Warranty claims shall be made by delivering the product for inspection to a Mercury dealer authorized to service the product. If purchaser cannot deliver the product to such a dealer, written notice must be given to Mercury. We will then arrange for the inspection and any covered repair. Purchaser in that case shall pay for all related transportation charges and/or travel time. If the service provided is not covered by this warranty, purchaser shall pay for all related labor and material, and any other expenses associated with that service. Purchaser shall not, unless requested by Mercury, ship the product or parts of the product directly to Mercury. The warranty registration card is the only valid registration identification and must be presented to the dealer at the time warranty service is requested in order to obtain coverage.

# WARRANTY INFORMATION

## WHAT IS NOT COVERED

This limited warranty does not cover electrical system corrosion; corrosion resulting from damage, corrosion, which causes purely cosmetic damage, abuse or improper service; corrosion to accessories, instruments, steering systems; corrosion to factory installed jet drive unit; damage due to marine growth; product sold with less than a one year limited Product warranty; replacement parts (parts purchased by customer); products used in a commercial application. Commercial use is defined as any work or employment related use of the product, or any use of the product, which generates income, for any part of the warranty period, even if the product is only occasionally used for such purposes.

Corrosion damage caused by stray electrical currents (on-shore power connections, nearby boats, submerged metal) is not covered by this corrosion warranty and should be protected against by the use of a corrosion protection system, such as the Mercury Precision Parts or Quicksilver MerCathode system and/or Galvanic Isolator. Corrosion damage caused by improper application of copper base anti-fouling paints is also not covered by this limited warranty. If anti-fouling protection is required, Tri-Butyl-Tin-Adipate (TBTA) base anti-fouling paints are recommended on Outboard and MerCruiser boating applications. In areas where TBTA base paints are prohibited by law, copper base paints can be used on the hull and transom. Do not apply paint to the outboard or MerCruiser product. In addition, care must be taken to avoid an electrical interconnection between the warranted product and the paint. Refer to the **Operation and Maintenance Manual** for additional details.

For additional information regarding events and circumstances covered by this warranty, and those that are not, refer to the **Warranty Coverage** section of the **Operation and Maintenance Manual**, incorporated by reference into this warranty.

**DISCLAIMERS AND LIMITATIONS: THE IMPLIED WARRANTIES OF MERCHANTABILITY AND FITNESS FOR A PARTICULAR PURPOSE ARE EXPRESSLY DISCLAIMED. TO THE EXTENT THAT THEY CANNOT BE DISCLAIMED, THE IMPLIED WARRANTIES ARE LIMITED IN DURATION TO THE LIFE OF THE EXPRESS WARRANTY. INCIDENTAL AND CONSEQUENTIAL DAMAGES ARE EXCLUDED FROM COVERAGE UNDER THIS WARRANTY. SOME STATES/COUNTRIES DO NOT ALLOW FOR THE DISCLAIMERS, LIMITATIONS AND EXCLUSIONS IDENTIFIED ABOVE, AS A RESULT, THEY MAY NOT APPLY TO YOU. THIS WARRANTY GIVES YOU SPECIFIC LEGAL RIGHTS, AND YOU MAY ALSO HAVE OTHER LEGAL RIGHTS, WHICH VARY FROM STATE TO STATE AND COUNTRY TO COUNTRY.**

# WARRANTY INFORMATION

## Warranty Coverage and Exclusions for Mercury Racing Outboard and Sterndrive Products

The purpose of this section is to help eliminate some of the more common misunderstandings regarding warranty coverage. The following information explains some of the types of services that are not covered by warranty. The provisions set forth following have been incorporated by reference into the Mercury Racing Division Three Year Limited Warranty Against Corrosion Failure, the Mercury Racing Division 90 Day and One Year Limited Warranties.

Keep in mind that warranty covers repairs that are needed within the warranty period because of defects in material and workmanship. Installation errors, accidents, normal wear, and a variety of other causes that affect the product are not covered.

Warranty is limited to defects in material or workmanship, but only to retail customers that purchase from a Dealer authorized by Mercury Marine to distribute the product in the country in which the sale occurred, and then only after the Mercury Marine specified pre-delivery inspection process is completed and documented.

Should you have any questions concerning warranty coverage, contact your authorized dealer. They will be pleased to answer any questions that you may have.

### GENERAL EXCLUSIONS FROM WARRANTY

1. Corrosion damage incurred by your 900 SC MerCruiser product(s) is not covered under this warranty.
2. Minor adjustments and tune-ups, including checking, cleaning or adjusting spark plugs, ignition components, carburetor or EFI settings, filters, belts, controls, and checking lubrication made in connection with normal services.
3. Damage caused by lack of maintenance.
4. Haul-out, launch, towing charges, and all related transportation charges and/or travel time, etc.
5. Additional service work requested by customer other than that necessary to satisfy the warranty obligation.
6. Labor performed by other than an authorized dealer may be covered only under following circumstances: When performed on emergency basis (providing there are no authorized dealers in the area who can perform the work required or have no facilities to haul out, etc., and prior factory approval has been given to have the work performed at this facility).



## WARRANTY INFORMATION

7. Use of other than Mercury Precision or Quicksilver parts when making warranty repairs.
8. Engine noise does not necessarily indicate a serious engine problem. If diagnosis indicates a serious internal engine condition, which could result in a failure, condition responsible for noise should be corrected under the warranty.
9. Lower unit and/or propeller damage caused by striking a submerged object is considered a marine hazard.
10. Water in the starter motor.
11. Starter motors and/or armatures or field coil assembly, which are burned, or where lead is thrown out of commutator because of excess cranking.
12. Valve or valve seat grinding required because of wear.

### California Emissions Limited Warranty

The California Air Resources Board has promulgated air emissions regulations for outboard engines. The regulations apply to all outboard engines sold to retail consumers in California, and which were manufactured for the 2001 model year, and later. Mercury Marine, in compliance with those regulations, provides this limited warranty for the emission control systems (see the components of the emission control system listed following), and further warrants that the outboard engine was designed, built and equipped to conform with all applicable regulations adopted by the California Air Resources Board pursuant to its authority in Chapters 1 and 2, Part 5, Division 26 of the Health and Safety Code. For information regarding the limited warranty for the non emissions related components of the outboard, please see the limited warranty statement for your outboard.

**WHAT IS COVERED:** Mercury Marine warrants the components of the emissions control systems (see the components of the emission control system listed following) of its new, 2001 model year (and later) outboards, sold by a California dealer to retail customers residing in California, to be free from defects in material or workmanship, that cause the failure of a warranted part to be identical in all material respects to that part as described in the application of Mercury Marine for certification from the California Air Resources Board, for the period of time, and under the conditions, identified below. The cost to diagnose a warranty failure is covered under the warranty (if the warranty claim is approved). Damage to other engine components caused by the failure of a warranted part will also be repaired under warranty.

# WARRANTY INFORMATION

**DURATION OF COVERAGE:** This limited warranty provides coverage for the components of the emissions control systems of new, 2001 model year (and later) outboards, sold to retail customers in California for 4 years from either the date the product is first sold, or first put into service, whichever occurs first, or the accumulation of 250 hours of engine operation (as determined by the engines hour meter, if any). Emission related normal maintenance items such as spark plugs and filters, that are on the warranted parts list (see following) are warranted up to their first required replacement interval only. (See **Maintenance - Inspection and Maintenance Schedule**). The repair or replacement of parts, or the performance of service under this warranty, does not extend the life of this warranty beyond its original expiration date. Unexpired warranty coverage can be transferred to a subsequent purchaser. (See instructions on transfer of warranty).

**HOW TO OBTAIN WARRANTY COVERAGE:** The customer must provide Mercury with a reasonable opportunity to repair, and reasonable access to the product for warranty service. Warranty claims shall be made by delivering the product for inspection to a Mercury dealer authorized to service the product. If purchaser cannot deliver the product to such a dealer, please notify Mercury Marine and Mercury will then arrange for the inspection and any covered repair. Purchaser in that case shall pay for all related transportation charges and/or travel time. If the service provided is not covered by this warranty, purchaser shall pay for all related labor and material, and any other expenses associated with that service. Purchaser shall not, unless requested by Mercury, ship the product or parts of the product directly to Mercury.

**WHAT MERCURY WILL DO:** Mercury Marine's sole and exclusive obligation under this warranty is limited to, at our expense and at our option, repairing or replacing defective parts with new or Mercury Marine certified re-manufactured parts, or refunding the purchase price of the Mercury product. Mercury reserves the right to improve or modify products from time to time without assuming an obligation to modify products previously manufactured.

# WARRANTY INFORMATION

**WHAT IS NOT COVERED:** This limited warranty does not cover routine maintenance items, tune ups, adjustments, normal wear and tear, damage caused by abuse, abnormal use, use of a propeller or gear ratio that does not allow the engine to run in its recommended wide open throttle RPM range (see **General Information - Specifications**), operation of the product in a manner inconsistent with the recommended operation procedures, neglect, accident, submersion, improper installation (proper installation specifications and techniques are set forth in the installation instructions for the product), improper service, use of an accessory or part not manufactured or sold by us, jet pump impellers and liners, operation with fuels, oils or lubricants which are not suitable for use with the product (see **Fuel and Oil**), alteration or removal of parts, or water entering the engine through the fuel intake, air intake or exhaust system. Use of the product for racing or other competitive activity, or operating with a racing type lower unit, at any point, even by a prior owner of the product, voids the warranty.

Expenses related to haul out, launch, towing, storage, telephone, rental, inconvenience, slip fees, insurance coverage, loan payments, loss of time, loss of income, or any other type of incidental or consequential damages are not covered by this warranty. Also, expenses associated with the removal and/or replacement of boat partitions or material caused by boat design for access to the product are not covered by this warranty.

Non-warranty maintenance, replacement, or repair of emission control devices and systems may be performed by any marine engine repair establishment or individual. The use of non-Mercury parts for non-warranty maintenance or repairs will not be grounds for disallowing other warranty work. The use of add-on (as defined at section 1900 (b)(1) and (b)(10) of Title 13 of the California Code of Regulations) or modified parts not exempted by the California Air Resources Board may be grounds for disallowing a warranty claim, at the discretion of Mercury Marine. Failures of warranted parts caused by the use of a non-exempted add-on or modified part will not be covered.

## COMPONENTS OF THE EMISSIONS CONTROL SYSTEM:

1. Fuel Metering System
  - a. Carburetor and internal parts (and/or pressure regulator or fuel injection system)
  - b. Cold start enrichment system
  - c. Intake valves
2. Air Induction System
  - a. Intake manifold
  - b. Turbocharger or supercharger systems (where applicable)

# WARRANTY INFORMATION

3. Ignition System
  - a. Spark plugs
  - b. Magneto or electronic ignition system
  - c. Spark advance/retard system
  - d. Ignition coil and/or control module
  - e. Ignition wires
4. Lubrication System
  - a. Oil pump and internal parts
  - b. Oil injectors
  - c. Oil meter
5. Exhaust system
  - a. Exhaust manifold
  - b. Exhaust valves
6. Miscellaneous Items Used in Above Systems
  - a. Hoses, clamps, fittings, tubing, sealing gaskets or devices, and mounting hardware.
  - b. Pulleys, belts and idlers.
  - c. Vacuum, temperature, check and time sensitive valves and switches
  - d. Electronic controls.

## **DISCLAIMERS AND LIMITATIONS**

**THE IMPLIED WARRANTIES OF MERCHANTABILITY AND FITNESS FOR A PARTICULAR PURPOSE ARE EXPRESSLY DISCLAIMED. TO THE EXTENT THAT THEY CANNOT BE DISCLAIMED, THE IMPLIED WARRANTIES ARE LIMITED IN DURATION TO THE LIFE OF THE EXPRESS WARRANTY. INCIDENTAL AND CONSEQUENTIAL DAMAGES ARE EXCLUDED FROM COVERAGE UNDER THIS WARRANTY. SOME STATES/COUNTRIES DO NOT ALLOW FOR THE DISCLAIMERS, LIMITATIONS AND EXCLUSIONS IDENTIFIED ABOVE, AS A RESULT, THEY MAY NOT APPLY TO YOU. THIS WARRANTY GIVES YOU SPECIFIC LEGAL RIGHTS, AND YOU MAY ALSO HAVE OTHER LEGAL RIGHTS WHICH VARY FROM STATE TO STATE AND COUNTRY TO COUNTRY.**

If you have any questions regarding your warranty rights and responsibilities, you should contact Mercury Marine at 1-920-929-5040.

# WARRANTY INFORMATION

## CALIFORNIA AIR RESOURCES BOARD EXPLANATION OF YOUR CALIFORNIA EMISSION CONTROL WARRANTY STATEMENT

**YOUR WARRANTY RIGHTS AND OBLIGATIONS:** The California Air Resources Board is pleased to explain the emission control system warranty on your 2001 model year and later outboard engine. In California, new outboard engines must be designed, built and equipped to meet the State's stringent anti-smog standards. Mercury Marine must warrant the emission control system on your outboard engine for the periods of time listed below provided there has been no abuse, neglect or improper maintenance of your outboard engine.

Your emission control system may include parts such as the carburetor or fuel injection system, the ignition system, and catalytic converter. Also included may be hoses, belts, connectors and other emission-related assemblies.

Where a warrantable condition exists, Mercury Marine will repair your outboard engine at no cost to you, including diagnosis, parts and labor.

**MANUFACTURER'S WARRANTY COVERAGE:** Select emission control parts from model year 2001 and later outboard engines are warranted for 4 years, or for 250 hours of use, whichever occurs first. However, warranty coverage based on the hourly period is only permitted for outboard engines and personal watercraft equipped with appropriate hour meters or their equivalent. If any emission related part on your engine is defective under warranty, the part will be repaired or replaced by Mercury Marine.

**OWNER'S WARRANTY RESPONSIBILITIES:** As the outboard engine owner, you are responsible for the performance of the required maintenance listed in the Maintenance section. Mercury Marine recommends that you retain all receipts covering maintenance on your outboard engine, but Mercury Marine cannot deny warranty solely for the lack of receipts or your failure to ensure the performance of all scheduled maintenance.

As the outboard engine owner, you should however be aware that Mercury Marine may deny you warranty coverage if your outboard engine or a part has failed due to abuse, neglect, improper maintenance or unapproved modifications.

You are responsible for presenting your outboard to a Mercury dealer authorized to service the product as soon as a problem exists. The warranty repairs will be completed in a reasonable amount of time, not to exceed 30 days.

If you have any questions regarding your warranty rights and responsibilities, you should contact Mercury Marine at 1-920-929-5040.

# WARRANTY INFORMATION

## Star Label





Outboards are labeled on the cowl with one of the following star labels.

**The Symbol for Cleaner Marine Engines Means:**

**Cleaner Air and Water** - for a healthier lifestyle and environment.

**Better Fuel Economy** - burns up to 30-40 percent less gas and oil than conventional carbureted two-stroke engines, saving money and resources.

**Longer Emission Warranty** - Protects consumer for worry free operation.

 <p>ob00708</p>	<p><b>One Star - Low Emission</b></p> <p>The one Star Label identifies engines that meet the Air Resources Board's 2001 exhaust emissions standards. Engines meeting these standards have 75% lower emissions than conventional carbureted two-stroke engines. These engines are equivalent to the U.S. EPA's 2006 standards for marine engines.</p>
 <p>ob00709</p>	<p><b>Two Stars - Very Low Emission</b></p> <p>The two Star Label identifies engines that meet the Air Resources Board's Personal Watercraft and Outboard marine engine 2004 exhaust emissions standards. Engines meeting these standards have 20% lower emissions than One Star - Low Emission engines.</p>
 <p>ob00710</p>	<p><b>Three Stars - Ultra Low Emission</b></p> <p>The three Star Label identifies engines that meet the Air Resources Board's personal Watercraft and Outboard marine engine 2008 exhaust emissions standards or the Sterndrive and Inboard marine engine 2003-2008 exhaust emission standards. Engines meeting these standards have 65% lower emissions than One Star - Low Emission engines.</p>
 <p>ob00711</p>	<p><b>Four Stars - Super Ultra Low Emission</b></p> <p>The four Star label identifies engines that meet the Air Resources Board's Sterndrive and Inboard marine engine 2009 exhaust emission standards. Personal Watercraft and Outboard marine engines may also comply with these standards. Engines meeting these standards have 90% lower emissions than One Star - Low Emission engines.</p>

# GENERAL INFORMATION

## Boater's Responsibilities

The operator (driver) is responsible for the correct and safe operation of the boat and safety of its occupants and general public. It is strongly recommended that each operator (driver) read and understand this entire manual before operating the outboard.

Be sure at least one additional person on board is instructed in the basics of starting and operating the outboard and boat handling in case the driver is unable to operate the boat.

## Before Operating Your Outboard

Read this manual carefully. Learn how to operate your outboard properly. If you have any questions, contact your dealer.

This manual as well as safety labels posted on the outboard use the following safety alerts to draw your attention to special safety instructions that should be followed.

### **WARNING**

**WARNING** - indicates a potentially hazardous situation that, if not avoided, could result in death or serious injury.

### **CAUTION**

**CAUTION** - indicates a potentially hazardous situation that, if not avoided, may result in minor or moderate injury or property damage. It may also be used to alert against unsafe practices.

## Boat Horsepower Capacity

### **WARNING**

Using an outboard that exceeds the maximum horsepower limit of a boat can: 1) cause loss of boat control 2) place too much weight at the transom altering the designed flotation characteristics of the boat or 3) cause the boat to break apart particularly around the transom area. Overpowering a boat can result in serious injury, death or boat damage.

# GENERAL INFORMATION

Do not overpower or overload your boat. Most boats will carry a required capacity plate indicating the maximum acceptable power and load as determined by the manufacturer following certain federal guidelines. If in doubt, contact your dealer or the boat manufacturer.

U.S. COAST GUARD CAPACITY	
MAXIMUM HORSEPOWER	XXX
MAXIMUM PERSON CAPACITY (POUNDS)	XXX
MAXIMUM WEIGHT CAPACITY	XXX

ob00306

## High-Speed And High-Performance Boat Operation

If your outboard is to be used on a high speed or high performance boat with which you are unfamiliar, we recommend that you never operate it at its high speed capability without first requesting an initial orientation and familiarization demonstration ride with your dealer or an operator experienced with your boat/outboard combination. For additional information, obtain a copy of our **Hi-Performance Boat Operation** booklet from your dealer, distributor, or Mercury Marine.



ob00307

## Outboard Remote Control Models

The remote control connected to your outboard must be equipped with a start in neutral only protection device. This prevents the engine from starting when the shift is actuated in any position other than neutral.



# GENERAL INFORMATION

## ⚠ WARNING

Avoid serious injury or death from a sudden unexpected acceleration when starting your engine. The design of this outboard requires that the remote control used with it must have a built in start in neutral only protection device.

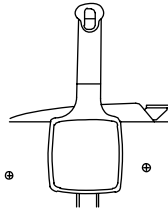

ob00308

## Remote Steering Notice

The steering link rod that connects the steering cable to the engine must be fastened utilizing self-locking nuts. These self-locking nuts must never be replaced with common nuts (non-locking) as they will work loose and vibrate off, freeing the link rod to disengage.

## ⚠ WARNING

Disengagement of a steering link rod can result in the boat taking a full, sudden, sharp turn. This potentially violent action can cause occupants to be thrown overboard exposing them to serious injury or death.

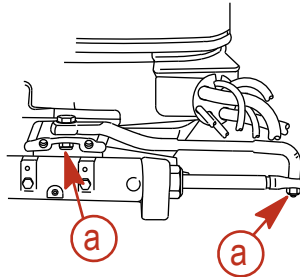

ob00655

**a** - Self-locking nuts

# GENERAL INFORMATION

## Lanyard Stop Switch

The purpose of a lanyard stop switch is to turn off the engine when the operator moves far enough away from the operator's position (as in accidental ejection from the operator's position) to activate the switch. A lanyard stop switch can be installed as an accessory - generally on the dashboard or side adjacent to the operator's position.

While activation of the lanyard stop switch will stop the engine immediately, a boat will continue to coast for some distance depending upon the velocity and degree of any turn at shut down. However, the boat will not complete a full circle. While the boat is coasting, it can cause injury to anyone in the boat's path as seriously as the boat would when under power.

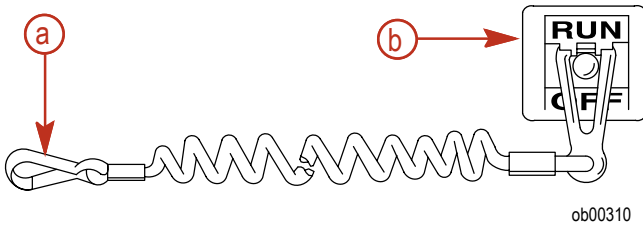

**a** - Lanyard cord

**b** - Lanyard stop switch

We strongly recommend that other occupants be instructed on proper starting and operating procedures should they be required to operate the engine in an emergency (e.g. if the operator is accidentally ejected).

### **⚠ WARNING**

Should the operator fall out of the boat, the possibility of serious injury or death from being run over by the boat can be greatly reduced by stopping the engine immediately. Always properly connect both ends of the stop switch lanyard to the stop switch and the operator.

### **⚠ WARNING**

Avoid serious injury or death from deceleration forces resulting from accidental or unintended stop switch activation. The boat operator should never leave the operator's station without first disconnecting the stop switch lanyard from the operator.

# GENERAL INFORMATION

Accidental or unintended activation of the switch during normal operation is also a possibility. This could cause any, or all, of the following potentially hazardous situations:

- Occupants could be thrown forward due to unexpected loss of forward motion - a particular concern for passengers in the front of the boat who could be ejected over the bow and possibly struck by the gear case or propeller.
- Loss of power and directional control in heavy seas, strong current or high winds.
- Loss of control when docking.

## Protecting People In The Water

### WHILE YOU ARE CRUISING

It is very difficult for a person in the water to take quick action to avoid a boat heading in their direction, even at slow speeds.



Always slow down and exercise extreme caution any time you are boating in an area where there might be people in the water.

Whenever a boat is moving (even coasting) and the gear shift is in "NEUTRAL," there is sufficient force by the water on the propeller to cause the propeller to rotate. This neutral propeller rotation can cause serious injury.

### WHILE BOAT IS STATIONARY

#### **⚠ WARNING**

**Stop your engine immediately whenever anyone in the water is near your boat. Serious injury to the person in the water is likely if contacted by a rotating propeller, a moving boat, a moving gearcase, or any solid device rigidly attached to a moving boat or gearcase.**

Shift into neutral and shut off the engine before allowing people to swim or be in the water near your boat.

# GENERAL INFORMATION

## Exhaust Emissions

### BE ALERT TO CARBON MONOXIDE POISONING

Carbon monoxide is present in the exhaust fumes of all internal combustion engines. This includes the outboards, sterndrives and inboard engines that propel boats, as well as the generators that power various boat accessories. Carbon monoxide is a deadly gas that is odorless, colorless and tasteless.

Early symptoms of carbon monoxide poisoning which should not be confused with seasickness or intoxication, include headache, dizziness, drowsiness, and nausea.

### **⚠ WARNING**

**Avoid the combination of a running engine and poor ventilation. Prolonged exposure to carbon monoxide in sufficient concentration can lead to unconsciousness, brain damage, or death.**

### GOOD VENTILATION

Ventilate passenger area, open side curtains, or forward hatches to remove fumes.

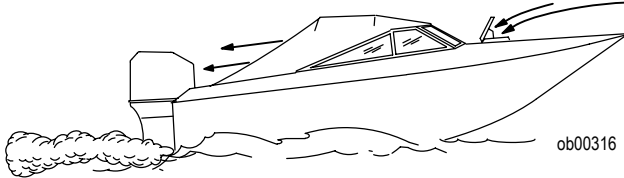

**Example of desired air flow through the boat.**

### POOR VENTILATION

Under certain running and/or wind conditions, permanently enclosed or canvas enclosed cabins or cockpits with insufficient ventilation may draw in carbon monoxide. Install one or more carbon monoxide detectors in your boat.

Although the occurrence is rare, on a very calm day, swimmers and passengers in an enclosed area of a stationary boat that contains or is near a running engine may be exposed to a hazardous level of carbon monoxide.

# GENERAL INFORMATION

## WHILE BOAT IS STATIONARY

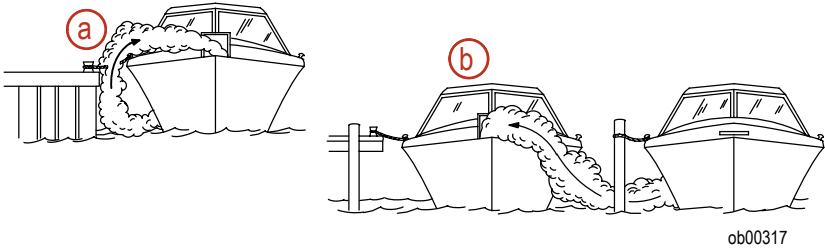

- a** - Running the engine when the boat is moored in a confined space.
- b** - Mooring close to another boat that has its engine running.

## WHILE BOAT IS MOVING

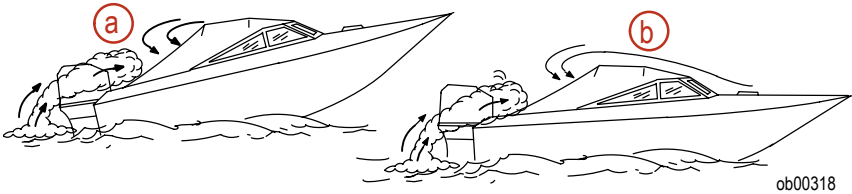

- a** - Running the boat with the trim angle of the bow too high.
- b** - Running the boat with no forward hatches open.

## Passenger Safety Message - Pontoon Boats And Deck Boats

Whenever the boat is in motion, observe the location of all passengers. Do not allow any passengers to stand or use seats other than those designated for traveling faster than idle speed. A sudden reduction in boat speed, such as plunging into a large wave or wake, a sudden throttle reduction, or a sharp change of boat direction, could throw them over the front of boat. Falling over the front of the boat between the two pontoons will position them to be run over by the outboard.

### BOATS HAVING AN OPEN FRONT DECK

No one should ever be on the deck in front of the fence while the boat is in motion. Keep all passengers behind the front fence or enclosure.

# GENERAL INFORMATION

Persons on the front deck could easily be thrown overboard or persons dangling their feet over the front edge could get their legs caught by a wave and pulled into the water.

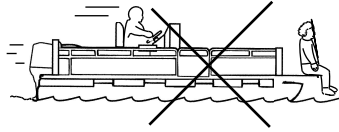

ob00312

## **⚠ WARNING**

**Avoid serious injury or death from falling over the front end of a pontoon or deck boat and being run over. Stay back from the front end of the deck and remain seated while the boat is in motion.**

## **BOATS WITH FRONT MOUNTED, RAISED PEDESTAL FISHING SEATS**

Elevated fishing seats are not intended for use when the boat is traveling faster than idle or trolling speed. Sit only in seats designated for traveling at faster speeds.

Any unexpected, sudden reduction in boat speed could result in the elevated passenger falling over the front of the boat.

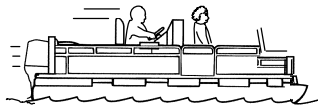
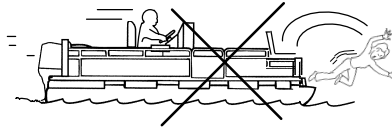

ob00313

# GENERAL INFORMATION

## Wave And Wake Jumping

Operating recreational boats over waves and wake is a natural part of boating. However, when this activity is done with sufficient speed to force the boat hull partially or completely out of the water, certain hazards arise, particularly when the boat re-enters the water.

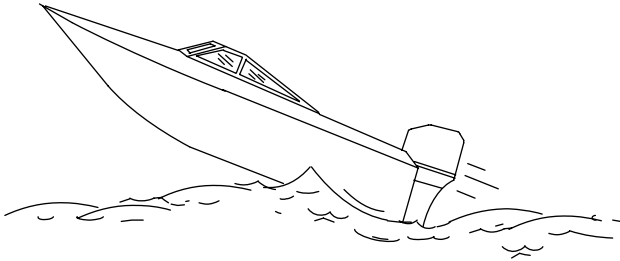

ob00314

The primary concern is the boat changing direction while in the midst of the jump. In such case the landing may cause the boat to veer violently in a new direction. Such a sharp change in direction can cause occupants to be thrown out of their seats, or out of the boat.

### **⚠ WARNING**

**Avoid serious injury or death from being thrown within or out of a boat when it lands after jumping a wave or wake. Avoid wave or wake jumping whenever possible. Instruct all occupants that if a wake or wave jump occurs, get low and hang on to a boat hand hold.**

There is another less common hazardous result from allowing your boat to launch off a wave or wake. If the bow of your boat pitches down far enough while airborne, upon water contact it may penetrate under the water surface and submarine for an instant. This will bring the boat to a nearly instantaneous stop and can send the occupants flying forward. The boat may also steer sharply to one side.

# GENERAL INFORMATION

## Impact With Underwater Hazards

Reduce speed and proceed with caution whenever you drive a boat in shallow water areas, or in areas where you suspect underwater obstacles may exist which could be struck by the outboard or the boat bottom. **The most important thing you can do to help reduce injury or impact damage from striking a floating or underwater object is to control the boat speed. Under these conditions, boat speed should be kept to a minimum planing speed 24 to 40 km/h (15 to 25 MPH).**

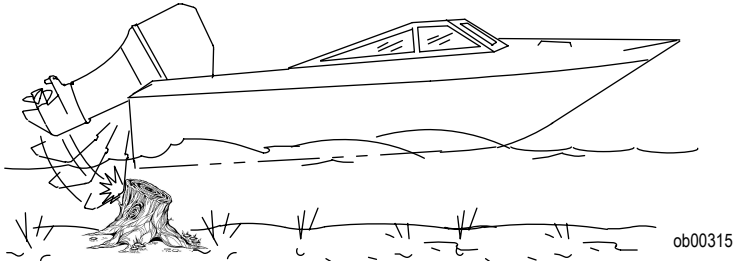

### **⚠ WARNING**

**To avoid serious injury or death from all or part of an outboard coming into the boat after striking a floating or underwater obstacle maintain a top speed no greater than minimum planing speed.**

Striking a floating or underwater object could result in an infinite number of situations. Some of these situations could result in the following:

- Part of the outboard or the entire outboard could break loose and fly into the boat.
- The boat could move suddenly in a new direction. Such a sharp change in direction can cause occupants to be thrown out of their seats or out of the boat.
- A rapid reduction in speed. This will cause occupants to be thrown forward, or even out of the boat.
- Impact damage to the outboard and/or boat.

Keep in mind, the most important thing you can do to help reduce injury or impact damage during an impact is control the boat speed. Boat speed should be kept to a minimum planing speed when driving in waters known to have underwater obstacles.

After striking a submerged object, stop the engine as soon as possible and inspect it for any broken or loose parts. If damage is present or suspected, the outboard should be taken to an authorized dealer for a thorough inspection and necessary repair.



## GENERAL INFORMATION

The boat should also be checked for any hull fractures, transom fractures, or water leaks.

Operating a damaged outboard could cause additional damage to other parts of the outboard, or could affect control of the boat. If continued running is necessary, do so at greatly reduced speeds.

### WARNING

**Avoid serious injury or death from loss of boat control. Continued boating with major impact damage can result in sudden outboard component failure with or without subsequent impacts. Have the outboard thoroughly inspected and any necessary repairs made.**

## Selecting Accessories For Your Outboard

Genuine Mercury Precision or Quicksilver Accessories have been specifically designed and tested for your outboard. These accessories are available from Mercury Marine dealers.

### WARNING

**Check with your dealer before installation of accessories. The misuse of acceptable accessories or the use of unacceptable accessories can result in serious injury, death, or product failure.**

Some accessories not manufactured or sold by Mercury Marine are not designed to be safely used with your outboard or outboard operating system. Acquire and read the installation, operation, and maintenance manuals for all your selected accessories.

## Safe Boating Suggestions

In order to safely enjoy the waterways, familiarize yourself with local and other governmental boating regulations and restrictions, and consider the following suggestions.

**Use flotation devices.** Have an approved personal flotation device of suitable size for each person aboard (it is the law) and have it readily accessible.

**Do not overload your boat.** Most boats are rated and certified for maximum load (weight) capacities (refer to your boat capacity plate). If in doubt, contact your dealer or the boats manufacturer.

**Perform safety checks and required maintenance.** Follow a regular schedule and ensure that all repairs are properly made.

# GENERAL INFORMATION

**Know and obey all nautical rules and laws of the waterways.** Boat operators should complete a boating safety course. Courses are offered in the U.S.A. by 1) The U.S. Coast Guard Auxiliary, 2) The Power Squadron, 3) The Red Cross and 4) your state boating law enforcement agency. Inquiries may be made to the Boating Hotline, 1-800-368-5647 or the Boat U.S. Foundation information number 1-800-336-BOAT.

**Make sure everyone in the boat is properly seated.** Do not allow anyone to sit or ride on any part of the boat that was not intended for such use. This includes the back of seats, gunwales, transom, bow, decks, raised fishing seats, any rotating fishing seat; or anywhere that an unexpected acceleration, sudden stopping, unexpected loss of boat control, or sudden boat movement could cause a person to be thrown overboard or into the boat.

**Never be under the influence of alcohol or drugs while boating (it is the law).** Alcohol or drug use impairs your judgment and greatly reduces your ability to react quickly.

**Prepare other boat operators.** Instruct at least one other person on board in the basics of starting and operating the outboard, and boat handling, in case the driver becomes disabled or falls overboard.

**Passenger boarding.** Stop the engine whenever passengers are boarding, unloading, or are near the back (stern) of the boat. Just shifting the outboard into neutral is not sufficient.

**Be alert.** The operator of the boat is responsible by law to maintain a proper lookout by sight and hearing. The operator must have an unobstructed view particularly to the front. No passengers, load, or fishing seats should block the operators view when operating the boat above idle speed.

**Never drive your boat directly behind a water skier in case the skier falls.** As an example, your boat traveling at 40 km/h (25 MPH) will overtake a fallen skier 61 m (200 ft.) in front of you in 5 seconds.

**Watch fallen skiers.** When using your boat for water skiing or similar activities, always keep a fallen or down skier on the operator's side of the boat while returning to assist the skier. The operator should always have the down skier in sight and never back up to the skier or anyone in the water.

# GENERAL INFORMATION

**Report accidents.** Boat operators are required by law to file a Boating Accident Report with their state boating law enforcement agency when their boat is involved in certain boating accidents. A boating accident must be reported if 1) there is loss of life or probable loss of life, 2) there is personal injury requiring medical treatment beyond first aid, 3) there is damage to boats or other property where the damage value exceeds \$500.00 or 4) there is complete loss of the boat. Seek further assistance from local law enforcement.

## Recording Serial Number

It is important to record this number for future reference. The serial number is located on the outboard as shown.

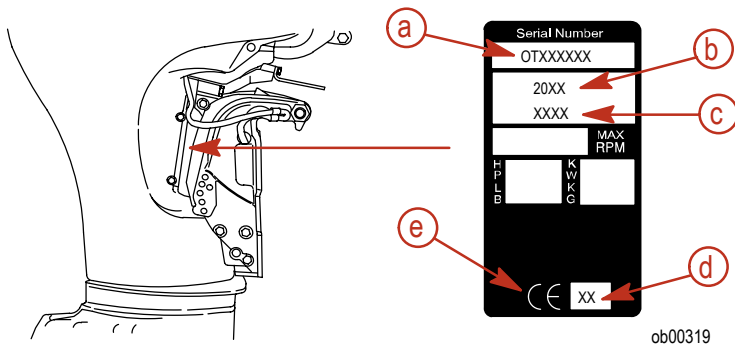

- a** - Serial number
- b** - Model year
- c** - Model designation

- d** - Year manufactured
- e** - Certified Europe Insignia (as applicable)

## Specifications - 225 Sport XS

### GENERAL

Description	Specifications
Cylinder Configuration	60 degree V6
Propshaft Horsepower	225
Propshaft Kilowatts	168
Engine Weight	229 kg (505 lb.)
Number of Cylinders	6
Idle RPM	575 RPM
Neutral Rev Limit	2250 RPM
Full Throttle RPM Range	5500 – 6000 RPM

# GENERAL INFORMATION

Description		Specifications
Overspeed Rev Limit		6300 RPM
Engine Displacement		3032 cc (185 cu. in.)
Cylinder Bore		92.075 mm (3.625 in.)
Stroke		76.2 mm (3.000 in.)
Recommended Spark Plug		NGK IZFR6J
Spark Plug Gap		0.81 mm (0.032 in.)
Firing Order		1-2-3-4-5-6
Maximum Timing:		Controlled by PCM
Idle Timing:		Controlled by PCM
Fuel Line Pressure		655 ± 13.8 kPa (95 ± 2 psi)
Air Pressure		758 ± 13.8 kPa (110 ± 2 psi)
Gear Ratio	Sport Master	1.62:1
Required Fuel		Unleaded 87 R+M/2 octane (92 RON)
Recommended Oil		Premium Plus TC-W3 2-Cycle
Gearcase Oil		Hi-Performance Gear Lube
Gearcase Lubricant Capacity		710 ml (24 fl oz)
Battery Rating		1000-MCA (Marine Cranking Amps) 800-CCA (Cold Cranking Amps) 105 Amp Hours <sup>1</sup> .
Charging System Output		50 Amps Max.

**NOTE:** Where applicable, specifications are derived at sea level.

## Special Tools and Kits

Description	Part Number
Stainless Steel Tilt Pin	17-49930A1
Flushing Attachment for Torque Master gearcase	44357T2
Dual Water Pick-Up Flush Seal Kit for Torque Master gearcase	881150K1

1. Battery manufacturers may rate and test their batteries to different standards. Consult with the specific battery manufacturer for comparison ratings.

# GENERAL INFORMATION

## Component Identification

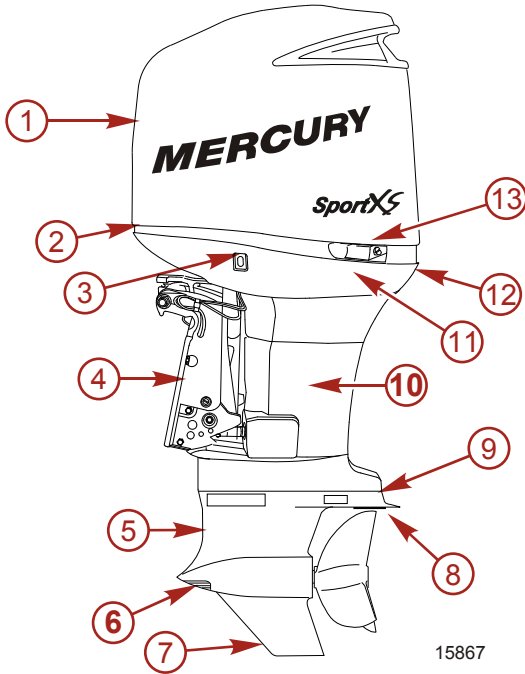

- |                           |                                       |
|---------------------------|---------------------------------------|
| 1 - Top cowl              | 8 - Anodes (one per side)             |
| 2 - Front cowl latch      | 9 - Anti-ventilation plate            |
| 3 - Auxiliary tilt switch | 10 - Driveshaft housing               |
| 4 - Clamp/Swivel bracket  | 11 - Bottom cowl                      |
| 5 - Gearcase              | 12 - Water pump indicator (tell tale) |
| 6 - Cooling water intake  | 13 - Side cowl latches (both sides)   |
| 7 - Skeg                  |                                       |

## Propeller Selection

Propping the engine at the higher end of the RPM range may increase acceleration, but decrease top boat speed. Conversely, propping the engine at the lower end of the range may increase top boat speed but hinder acceleration. Mercury Marine recommends selecting a propeller that allows the engine to operate in the upper half of the recommended full throttle RPM range with the boat normally loaded (refer to **General Information - Specifications**). This RPM range allows for better acceleration while maintaining maximum boat speed.

# GENERAL INFORMATION

If full throttle operation is below the recommended full throttle range, the propeller must be changed to prevent loss of performance and possible engine damage. On the other hand, operating an engine above the recommended operating RPM range will cause higher than normal wear or damage. Generally, there is a 200-300 RPM change between propeller pitches.

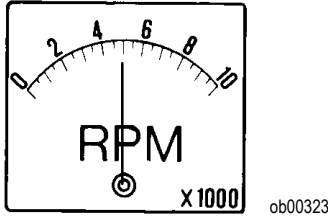

If changing conditions cause the RPM to drop below the recommended range (such as warmer, more humid weather, operation at higher elevations, increased boat load, or a dirty boat bottom/gearcase), a propeller change or cleaning may be required to maintain performance and ensure the outboards durability.

Check full-throttle RPM, using an accurate tachometer, with the engine trimmed out to a balanced-steering condition (steering effort equal in both directions) without causing the propeller to break loose.

# TRANSPORTING

## Trailing Boat/Outboard

Ensure that the outboard is in forward gear before trailering. This prevents the propeller from spinning freely during transportation.

### **⚠ CAUTION**

**Avoid equipment damage. Always shift the gearcase into gear when the engine is running and is operating at idle. Shifting into gear at engine speeds above idle will damage the gearcase. Shifting into gear when the engine is not running may cause clutch misalignment, preventing the gearcase from shifting into gear.**

Trailer your boat with the outboard tilted down in a vertical operating position. If additional ground clearance is required, the outboard should be tilted up using an accessory outboard support device. Refer to your local dealer for recommendations. Additional clearance may be required for railroad crossings, driveways and trailer bouncing.

**IMPORTANT: Do not rely on the power trim/tilt system or tilt support lever to maintain proper ground clearance for trailering. The outboard tilt support lever is not intended to support the outboard for trailering.**

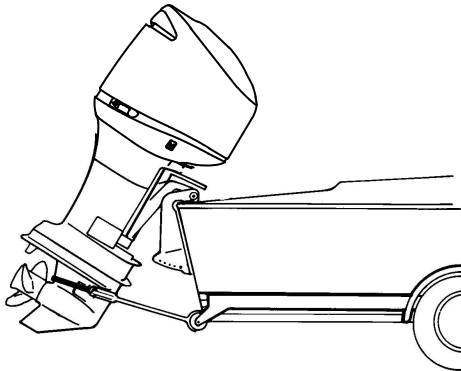

or26

# FUEL AND OIL

## Avoiding Fuel Flow Restrictions

### ⚠ CAUTION

Avoid engine damage. Adding components to the fuel supply system, such as filters, valves, fittings, etc., may restrict the fuel flow. This condition may cause the engine to stall at low speeds and create lean fuel conditions at high speeds, causing engine damage.

## Fuel Requirements

Use a major brand of unleaded gasoline, preferably without alcohol.

### ⚠ CAUTION

Avoid equipment damage. Use of improper fuel can seriously damage your engine. Engine damage resulting from the use of improper fuel is considered engine misuse and is not covered under the limited warranty.

## OCTANE REQUIREMENTS (U.S./CANADA)

FUEL TYPE	MINIMUM POSTED OCTANE
Unleaded premium <sup>1</sup> .	87 (R+M)/2

## OCTANE REQUIREMENTS (OUTSIDE THE U.S./CANADA)

FUEL TYPE	MINIMUM POSTED OCTANE
Unleaded premium <sup>2</sup> .	92 RON

## USING REFORMULATED (OXYGENATED) FUELS (USA ONLY)

This type of fuel is required in certain areas of the U.S. The two types of oxygenates used in these fuels are alcohol (Ethanol) or Ether (MTBE or ETBE). If Ethanol is the oxygenate that is used in the gasoline in your area, refer to the **Fuel Containing Alcohol** section.

These reformulated fuels are acceptable for use in your Mercury engine.

1. Mercury Marine does not recommend using leaded gasoline. Read the information in the Fuel Containing Alcohol section.
2. Mercury Marine does not recommend using leaded gasoline. Leaded gasoline is acceptable in areas where unleaded gasoline is not available; however, exhaust passageway corrosion may occur due to the accumulation of exhausted lead particles. Automotive fuels that contain fuel injector cleaner are recommended for added internal cleanliness.



# FUEL AND OIL

## FUEL CONTAINING ALCOHOL

If the fuel in your area contains either methanol (methyl alcohol) or ethanol (ethyl alcohol), you should be aware of certain adverse effects that can occur. These adverse effects are more severe with methanol. Increasing the percentage of alcohol in the fuel can also worsen these adverse effects.

Some of these adverse effects are caused because the alcohol in the fuel can absorb moisture from the air, resulting in a separation of the water/alcohol from the gasoline in the fuel tank.

The fuel system components on your Mercury engine will withstand up to 10% alcohol content in the gasoline. We do not know what percentage your boat's fuel system will withstand. Contact your boat manufacturer for specific recommendations on the boat's fuel system components (fuel tanks, fuel lines, and fittings).

Fuel containing alcohol may increase:

- Corrosion of metal parts.
- Deterioration of rubber or plastic parts.
- Fuel permeation through rubber fuel lines.
- Starting and operating difficulties.

### CAUTION

When operating a Mercury engine with fuel containing alcohol, avoid storing the fuel in the fuel tank for long periods of time. Long storage periods, common to boats, create unique problems. In cars, alcohol-blend fuels are normally consumed before they can absorb enough moisture to cause trouble. However, boats often sit idle long enough for phase separation to take place. In addition, internal corrosion may take place during storage if alcohol has washed protective oil films from internal components.

**IMPORTANT:** Because of possible adverse effects of alcohol in gasoline, it is recommended that only alcohol-free fuel be used where possible.

If only fuel containing alcohol is available, or if the presence of alcohol is unknown, increased inspection frequency for leaks and abnormalities is required.

## Oil Recommendation

Recommended Oil	Premium Plus 2-Cycle TC-W3 Outboard Oil
-----------------	---

# FUEL AND OIL

TC-W3 Premium Plus Outboard Oil is a higher grade oil that provides increased lubrication and extra resistance to carbon buildup when used with good or varying grades of gasoline.

**IMPORTANT: Oil must be NMMA certified TC-W3 2-Cycle oil.**

Periodically consult with your dealer to get the latest gasoline and oil recommendations. If Quicksilver 2-Cycle Outboard Oil is not available, substitute another brand of 2-Cycle outboard oil that is NMMA Certified TC-W3. The use of an inferior 2-Cycle outboard oil can reduce engine durability. Damage from use of inferior oil may not be covered under the limited warranty.

## Filling Remote Oil Tank

Remove filler cap and fill with the specified oil. Oil tank capacity is 11.5 liters (3 gallons). Replace filler cap and tighten securely.

**IMPORTANT: Always make sure the oil tank caps are threaded on tight. An air leak will prevent oil flow to the engine.**

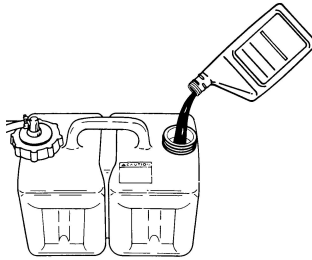

or27

## Filling Engine Mounted Oil Reservoir Tank

Remove the top cowl. Loosen the fill cap on the engine oil reservoir tank. Run the engine until all the air has been vented out of the oil reservoir tank and tank is filled with oil to the point of overflow. Re-tighten the fill cap. Stop the engine and replace the top cowl.

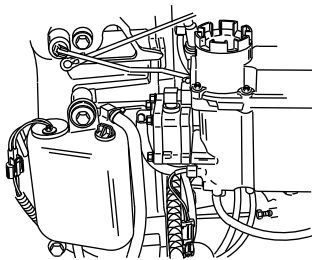

or28

## FUEL AND OIL

*NOTE: Filling this tank is only necessary if the oil level should ever drop and the low oil warning system is activated.*

### Filling Fuel Tank

- Fill fuel tanks outdoors away from heat, sparks, and open flames.
- Remove portable fuel tanks from boat to refill them.
- Always stop engine before refilling tanks.
- Do not completely fill the fuel tanks. Leave approximately 10% of the tank volume unfilled. Fuel will expand in volume as its temperature rises and can leak under pressure if the tank is completely filled.

#### **WARNING**

**Avoid serious injury or death from a gasoline fire or explosion. Always stop the engine and do not smoke or allow open flames or sparks in the area while filling fuel tanks.**

# FEATURES AND CONTROLS

## Remote Control Features

Your boat may be equipped with one of the Mercury Precision or Quicksilver remote controls shown. If not, consult your dealer for a description of the functions and operations of the remote control.

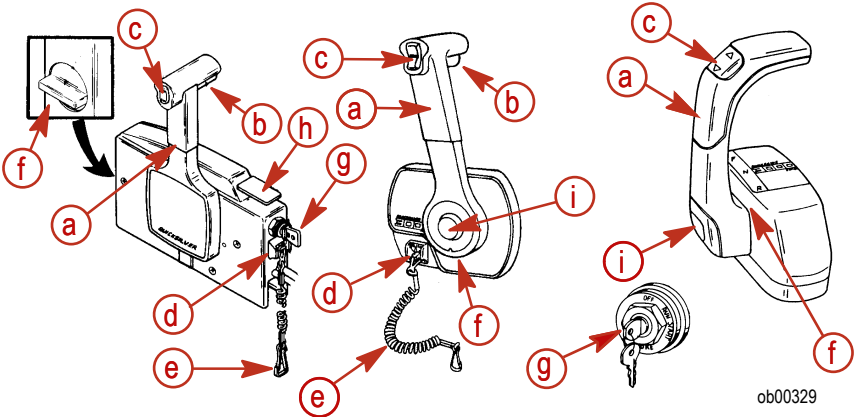

- a** - Control handle - forward, neutral, reverse.
- b** - Neutral release lever
- c** - Trim/tilt switch (if equipped). - Refer to **Features & Controls - Power Trim and Tilt**.
- d** - Lanyard stop switch - Refer to **General Information - Lanyard Stop Switch**.
- e** - Lanyard - Refer to **General Information - Lanyard Stop Switch**.
- f** - Throttle friction adjustment - Console controls require cover removal for adjustment.
- g** - Ignition key switch - "OFF," "ON," START."
- h** - Fast idle lever - Refer to **Operation - Starting the Engine**.
- i** - Throttle only button - Refer to **Operation - Starting the Engine**.

# FEATURES AND CONTROLS

## Zero Effort Control Features

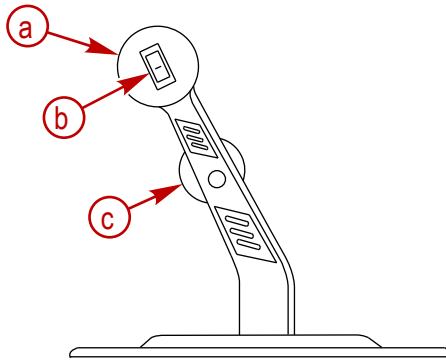

4090

- a** - Throttle lever
- b** - Trim switch
- c** - Shift lever

## Warning System

The warning system incorporates a warning horn inside the boat. The warning horn may be located inside the remote control or under the dash connected to the ignition key switch.

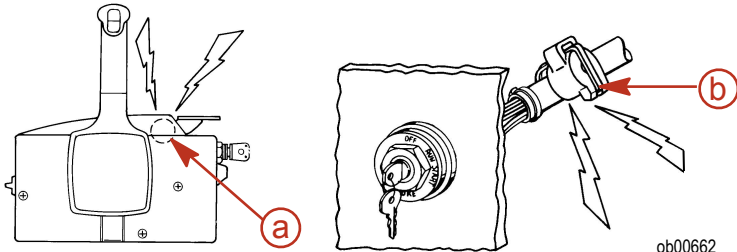

ob00662

- a** - Inside the remote control
- b** - Under the dashboard

## WARNING HORN SIGNALS

When the key switch is turned to the "ON" position, the horn will turn on for a moment as a test to tell you the horn is working.

# FEATURES AND CONTROLS

The warning horn will emit either a continuous beep or intermittent short beeps. This will alert the operator and help identify the following listed situations. Refer to the **Troubleshooting** section for specific information. For visual display of the specific engine functions and for additional engine data, refer to SmartCraft product information.

## ENGINE GUARDIAN SYSTEM

The Engine Guardian System monitors the critical sensors on the engine for any early indications of problems. The system will respond to a problem by emitting a continuous beep and/or reducing engine power in order to provide engine protection.

If Guardian System is activated, the system must be reset before the engine will operate at higher speeds. Moving throttle lever back to idle, or to the required reduced throttle position, resets the system.

Problem	Horn	Monitor Display	Guardian Activated	Percentage of Full Engine Power Available
Power Up/ System Check	Single Beep	Yes	N/A	N/A
During Engine Break-In	No	No	No	100%
Low Oil in Engine Oil Tank	4 Beeps... 2 Minutes Off	Yes	Yes	95%
Critically Low Oil in Engine Oil Tank	Continuous Beep	Yes	Yes	5%
Oil Pump Electrical Failure	Continuous Beep	Yes	Yes	5%
Throttle Position Sensor Failure	Continuous Intermittent Beeping	Yes	Yes	95%
Overspeed	Continuous Beep	Yes	Yes	65%
High Engine Temperature	Continuous Beep	Yes	Yes	From 100% down to 4%
Low Block Water Pressure	Continuous Beep	Yes	Yes	From 100% down to 4%
Faulty Sensor (Block psi, Coolant Temp)	No	Yes	Yes	95%

## FEATURES AND CONTROLS

Problem	Horn	Monitor Display	Guardian Activated	Percentage of Full Engine Power Available
Battery Voltage Out of Limits	Single Beep...Continuous Beep when Guardian Engages	Yes	Yes	<10 v = 0% <11.5 v = 50%
		No	No	11.5 - 16 v = 100%
		Yes	Yes	>16 v = 50% >17 v = 0%
Horn Failure	No	Yes	Yes	95%
Water In Fuel	4 Beeps... 2 Minutes Off	Yes	No	N/A
MAP Sensor Failure	No	Yes	Yes	95%
Air Temperature Sensor Failure	No	Yes	No	N/A
Ignition Coil Failure	No	Yes	No	N/A
Injector Failure	No	Yes	No	N/A

### SMARTCRAFT PRODUCT

A Mercury SmartCraft System instrument package can be purchased for this power package. A few functions the instrument packages display are:

- Engine RPM
- Coolant temp
- Water pressure
- Battery voltage
- Fuel consumption
- Engine operating hours

The SmartCraft Instrument package will also aid in Engine Guardian diagnostics. The SmartCraft Instrument package will display critical engine alarm data and potential problems.

Refer to the **Mercury SmartCraft Operator's Supplement** provided with the power package for the warning functions monitored on your power package and basic operation of the SmartCraft Instrument package.

# FEATURES AND CONTROLS

## Overspeed Rev Limit

The overspeed rev limit is set at an RPM greater than the operating range. In the event that the engine is operated at an RPM greater than or equal to the overspeed limit, the PCM does not allow the engine to maintain the power required. Refer to **Specifications** to determine this engine's RPM limit.

Upon reaching the rev limit, the Guardian System activates the warning horn. If the operator does not reduce engine speed within five seconds, the Guardian Systems reduces available engine power.

To reset the Guardian System protection:

1. Completely reduce throttle for two to three seconds.
2. Re-engage the throttle. If the engine does not respond, repeat step one.

## Power Trim And Tilt

**NOTE:** Outboard position can be adjusted by pressing trim switch. The trim range is used while operating your boat on plane. The tilt range is used when the engine is not running.

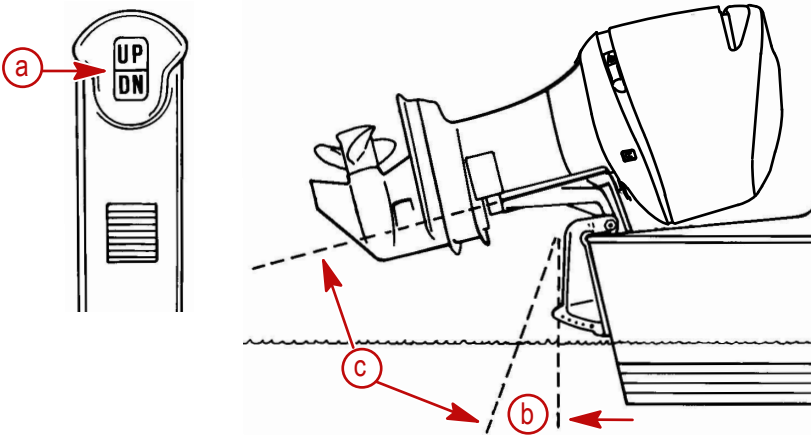

or30-1

- a** - Trim switch
- b** - Trim range
- c** - Tilt range

- **Pressing (DN):** Moves the outboard in closer to the boat transom, called trimming in or down.
- **Pressing (UP):** Moves the outboard further away from the boat transom, called trimming out or up.



# FEATURES AND CONTROLS

- **The term trim** generally refers to the adjustment of the outboard within the first 20° range of travel.
- **The term tilt** generally refers to adjusting the outboard further up out of the water or beyond the transom bracket support.

With the engine turned off, the outboard can be tilted out of the water. At low idle speed, the outboard can also be tilted up past the trim range to permit, for example, shallow water operation.

## Power Trim Operation

With most boats, operating around the middle of the trim range will give satisfactory results. Trimming your outboard all the way in or out may improve performance, but cause some potential control hazards.

### **WARNING**

**Avoid possible serious injury or death. When the outboard is trimmed in or out beyond a neutral steering condition, a pull on the steering wheel in either direction may result. Failure to keep a continuous firm grip on the steering wheel when this condition exists can result in loss of boat control as the outboard can turn freely. The boat can now spin out or go into a very tight maximum turn which, if unexpected, can result in occupants being thrown within the boat or out of the boat.**

Consider the following lists carefully.

Trimming in/down can:

- Lower the bow of the boat.
- Result in quicker planing off.
- Generally improve the ride in choppy water.
- Increase steering torque or pull to the right (with the normal right-hand rotation propeller).
- In excess, lower the bow to a point at which the boat begins to plow with the bow in the water while on plane. This can result in an unexpected turn in either direction called bow steering or over steering if any turn is attempted, or if a significant wave is encountered.

Trimming out/up can:

- Lift the bow higher out of the water.
- Generally increase top speed.
- Gain clearance over submerged objects or a shallow bottom.
- Increase steering torque or pull to the left at a normal installation height (with the normal right hand rotation propeller).

# FEATURES AND CONTROLS

- Cause boat porpoising (bouncing) or propeller ventilation.
- Cause engine overheating if any cooling water intake holes are above the water line.

## LIMITING TRIM IN

In rare circumstances, the owner may decide to limit the trim in to avoid unsafe handling or steering conditions at planing speeds.

### **⚠ WARNING**

Avoid possible serious injury or death. Adjust outboard to an intermediate trim position as soon as boat is on plane to avoid possible ejection due to boat spin out. Do not attempt to turn boat when on plane if outboard is trimmed extremely in or down and there is a pull on the steering wheel.

### **⚠ WARNING**

Avoid possible injury or death. Always perform a water test to examine boat handling and steering after making any trim in limiting adjustments. Operating a boat with a full trim angle without the aid of a trim in limiting device may result in undesirable or unsafe steering conditions.

**IMPORTANT:** Some boat/engine combinations not using a trim angle adjustment device, or trimmed to the full trim in position, may not exhibit any undesirable or unsafe handling or steering conditions. In these cases, a trim limiting device may not be advantageous to acceleration or planing. Always perform a water test to determine if these characteristics apply to a particular boat/engine combination.

Purchase a stainless steel tilt pin from your dealer and insert it in whatever adjustment hole in the transom brackets is desired.

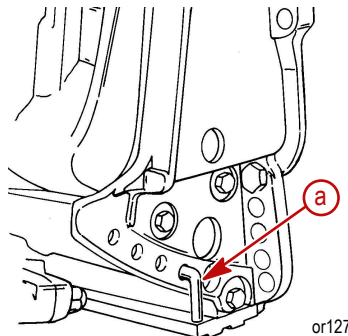

**a** - Stainless steel tilt pin (Three-Ram trim system)

# FEATURES AND CONTROLS

## Power Tilt Operation (Three-Ram Trim Systems)

To tilt the outboard, shut off the engine and press the trim/tilt switch or the auxiliary tilt switch (located on the cowl) to the up position. The outboard tilts up until the switch is released or it reaches the maximum tilt position.

1. Engage the tilt support lever by pushing the metal stop and rotating the knob to bring the support lever upward.

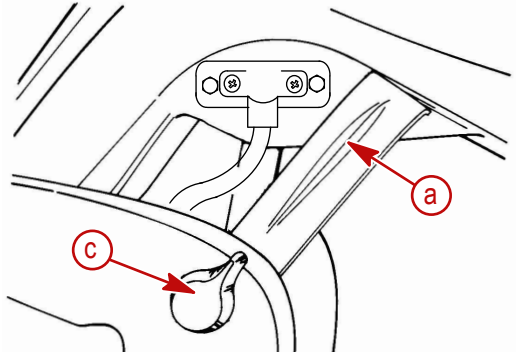
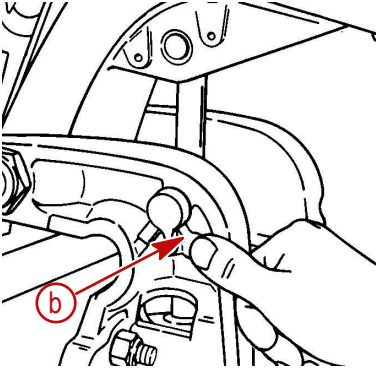

or33-1

- a** - Tilt support lever
- b** - Metal stop
- c** - Knob

2. Lower the outboard to rest on the tilt support lever.
3. Disengage the tilt support lever by raising the outboard off the support lever and rotating the lever until it locks. Lower the outboard.

# FEATURES AND CONTROLS

## Auxiliary Tilt Switch

This switch can be used to tilt the outboard up or down using the power trim system.

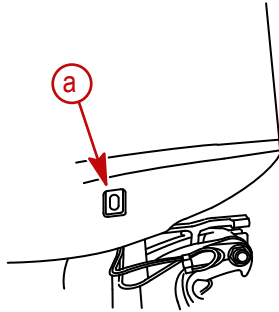

or54-1

**a** - Auxiliary tilt switch

## Manual Tilt Operation

If the outboard cannot be tilted using the power trim/tilt switch, the outboard can be tilted manually.

1. Turn out the manual tilt release valve three turns (counter-clockwise). This allows manual tilting of the outboard.

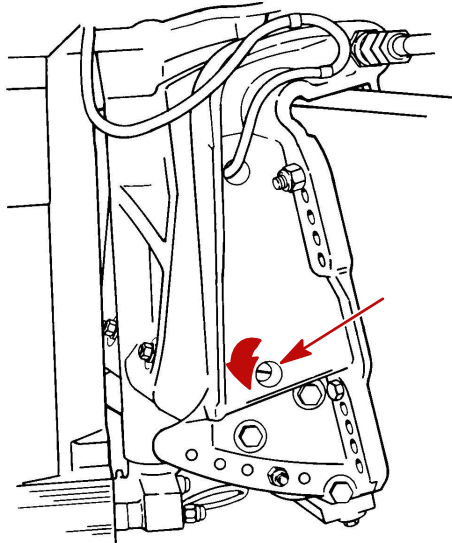

or34-1

## FEATURES AND CONTROLS

2. Tilt the outboard to the desired position and tighten the manual tilt release valve.

***NOTE:*** *The manual tilt release valve must be tightened before operating the outboard to prevent the outboard from tilting up during reverse operation.*

# OPERATION

## Engine Break-in

### CAUTION

Severe damage to the engine can result by not complying with the engine break-in procedure. Engine damage may not be covered by the limited warranty.

### WARNING

Avoid loss of boat control or an unsafe boat handling situation. Increasing trim under can place greater load on an engine and enhance breakin. At higher speeds, increasing trim under could produce a dangerous boat handling situation. It is the boat operator's responsibility to always drive in a safe manner.

#### Break-in Procedure

Always vary throttle settings during Break-in

##### 1st Hour

- Allow engine to warm-up for 30 - 60 seconds.
- Do not idle for more than 5 minutes
- Run the engine the majority of the time between 4000 - 5400 RPM (approximately three quarter throttle).
- Change engine speed approximately every two (2) minutes.
- Avoid trimming the outboard out (up) beyond a vertical trim position during operation.
- Avoid using hydraulic jack plate (if equipped) to raise engine during break-in cycle.

**Next 3 Hours:** Change engine speed every 10 minutes.

## Engine Break-in Fuel Mixture

### CAUTION

**Avoid engine damage. Do not add oil to the gasoline in the fuel tank.**

The Propulsion Control Module (PCM) controls oil and fuel mixture during engine break-in.

## Pre-Starting Check List

- Engine lowered to run position with all water intake holes submerged

# OPERATION

- Fuel tank vent cap open or fuel drain valve on.
- Fuel supply OK
- Lanyard stop switch in "RUN" position and cord connected.
- Remote control in neutral
- Top cowl latches secure.
- Make inspection checks listed in the Inspection and Maintenance Schedule. Refer to **Maintenance** section.

## Operating In Freezing Temperatures

When using your outboard or having your outboard moored in freezing or near freezing temperatures, keep the outboard tilted down at all times so the gearcase is submerged. This prevents trapped water in gearcase from freezing and causing possible damage to the water pump and other components.

If there is a chance of ice forming on the water, the outboard should be removed and drained completely of water. If ice should form at the water level inside the outboard driveshaft housing, it will block water flow to the engine causing possible damage.

## Operating In Salt Water Or Polluted Water

We recommend that you flush the internal water passages of your outboard with fresh water after each use in salt or polluted water. This will prevent a buildup of deposits from clogging the water passages. Refer to **Maintenance - Flushing The Cooling System**.

If you keep your boat moored in the water, always tilt the outboard so the gearcase is completely out of water (except in freezing temperatures) when not in use.

Wash the outboard exterior and flush out the exhaust outlet of the propeller and gearcase with fresh water after each use. Each month, spray Mercury Precision or Quicksilver Corrosion Guard on external metal surfaces. Do not spray on corrosion control anodes as this will reduce the effectiveness of the anodes.

## Operating at High Elevations

Your engine automatically compensates for high elevation changes. A different pitch propeller may help reduce some normal performance loss resulting from reduced oxygen in the air. Consult your dealer.

# OPERATION

## Effects of Elevation and Weather on Performance

The following conditions lower engine performance and cannot be compensated by the engine fuel or electronic management systems.

- Above sea level elevations
- High temperature.
- Low barometric pressure.
- High humidity.

These conditions above reduce air density to the engine, which in turn lowers the following:

- Boost pressure on supercharged engines
- Horsepower and torque throughout the RPM range
- Peak RPM
- Cranking compression

EXAMPLE: An engine run at an elevation of 8,000 feet will have over a 30% power loss while a loss of engine power on a hot and humid day could be as much as 14%. These losses apply to normally aspirated and supercharged engines.

### Compensating for power robbing conditions:

- Switch to lower pitch propeller.
- Change gear ratio.

Some boat performance can be regained by dropping to a lower pitch propeller but engine performance will still remain lower. In some cases, a gear ratio reduction may be more beneficial. To optimize engine performance, prop the engine to allow it to operate at or near the top end of the recommended maximum RPM range at wide-open-throttle with a normal boat load.

Other advantages to propeller or gear ratio changes:

- Reduces the possibility of detonation.
- Enhances overall reliability and durability of the engine.



# OPERATION

## Setting Trim Angle While Running Engine at Idle Speed

Submerging the exhaust relief hole on the outboard can happen on some boats if you trim full in while running at idle speed, resulting in, exhaust restriction, rough idle, excessive smoke, and fouled spark plugs. If this condition exists, trim outboard up until exhaust relief hole is out of the water.

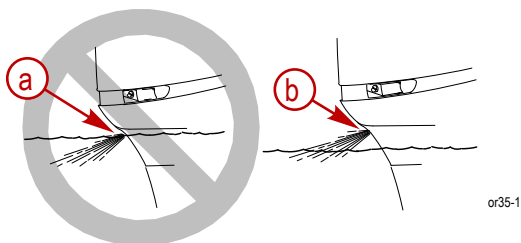

- a** - Relief hole submerged (wrong)
- b** - Relief hole above water line (correct)

## Operating in Shallow Water

When operating your boat in shallow water, you can tilt the outboard beyond the maximum trim range to prevent hitting bottom.

### **⚠ CAUTION**

**Avoid engine or transom damage. Do not exceed 2000 RPM when the outboard is being operated in the tilt range.**

1. Reduce engine speed below 2000 RPM.
2. Tilt outboard up. Make sure all the cooling water intake holes stay submerged at all times.
3. Operate the engine at slow speed only.

Models with a three-ram trim system: If engine speed exceeds 2000 RPM, the outboard will automatically return down to the maximum trim range.

Models with a single-ram trim system: The outboard will remain at the selected tilt position, regardless of engine RPM.

# OPERATION

## Starting The Engine

### ⚠ CAUTION

Never start or operate your outboard (even momentarily) without water circulating through all the cooling water intake holes in the gearcase to prevent damage to the water pump (running dry) or overheating of the engine.

### INITIAL STARTING PROCEDURE

**NOTE:** For initial start up of a new engine, or for an engine that ran out of fuel or was drained of fuel, the fuel system should be filled according to the following procedure.

1. Squeeze the fuel line primer bulb until it feels firm.
2. Turn the ignition key switch to the "ON" position for three seconds. This operates the electric fuel pump.
3. Turn the ignition key switch back to the "OFF" position, and squeeze the primer bulb again until it feels firm. Turn the ignition key switch to the "ON" position again for three seconds. Continue this procedure until the fuel line primer bulb stays firm.

Before starting, read the **Pre-Starting Check List, Special Operating Instructions**, in the **Operation Section**.

### STARTING PROCEDURE

1. Lower the outboard to the "RUN" position. Make sure all the cooling water intake holes are submerged.

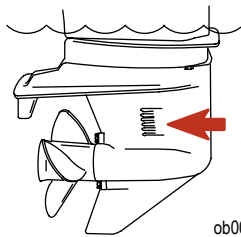

2. Open fuel tank filler cap vent screw (manual venting fuel tanks).

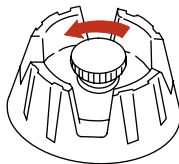

# OPERATION

3. Squeeze the fuel line primer bulb several times until it feels firm.

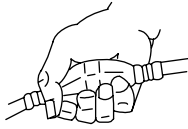

ob00349

4. Set the lanyard stop switch to the "RUN" position. Read the Lanyard Stop Switch safety explanation and warning in the **General Information** section.



ob00350

5. Shift the outboard to the neutral position.

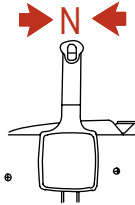

ob00351

6. Do not advance the neutral fast idle speed feature on the remote control for starting (if equipped).

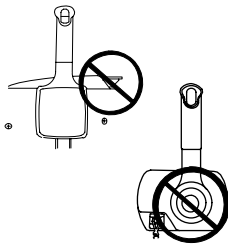

ob00560

# OPERATION

7. Turn the ignition key to the "START" position. Release the key when the engine starts. If the engine fails to start in ten seconds, return the key to the "OFF" position, wait one second, and try again.

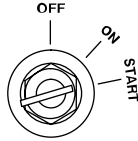

ob00354

8. Check for water coming out of the water pump indicator hole.

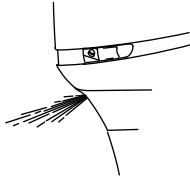

or55

**NOTE:** The electronic starting system will automatically prime (choke) the engine and increase idle speed for starting.

## **⚠ CAUTION**

Avoid possible engine damage. If no water is coming out of the water pump indicator hole, stop the engine and check the cooling water intake holes for obstruction. No obstruction may indicate a water pump failure or blockage in the cooling system. These conditions will cause the engine to overheat. Have the outboard checked by your authorized Mercury Marine dealer. Operating the engine while overheated will cause engine damage.

# OPERATION

## Gear Shifting

### ⚠ CAUTION

Avoid equipment damage. Always shift the gearcase into gear when the engine is running and is operating at idle. Shifting into gear at engine speeds above idle will damage the gearcase. Shifting into gear when the engine is not running may cause clutch misalignment, preventing the gearcase from shifting into gear.

- Your outboard has three gear shift positions to provide operation: forward, neutral (out of gear) and reverse.

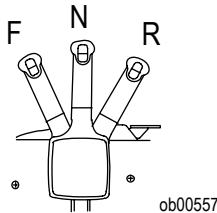

- When shifting, always stop at neutral position and allow the engine speed to return to idle.
- Always shift into gear with a quick motion.
- After shifting into gear, advance the lever further to increase speed.

## Stopping The Engine

Reduce engine speed and shift outboard to neutral position. Turn ignition key to "OFF" position.

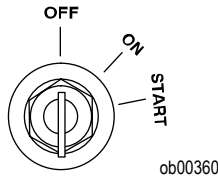

# MAINTENANCE

## Power Package Care

### WARNING

Avoid equipment damage, serious injury or death from improper or neglected maintenance, repairs or inspections of the power package. If you are not familiar with proper maintenance or service procedures, have the work performed by an authorized Mercury Marine dealer.

To ensure safety and retain dependability, keep your power package in the best operating condition by performing the periodic inspections and maintenance listed in the **Inspection and Maintenance Schedule**. Record maintenance performed in the **Maintenance Log** at the back of this book. Save all maintenance work orders and receipts.

## Submerged Power Package

A submerged power package requires prompt service by an authorized dealer after recovery. This immediate attention is necessary once the engine is exposed to the atmosphere to minimize internal corrosion damage to the engine.

## Replacement Parts for Your Power Package

### WARNING

Using a replacement part that is inferior to the original part could result in personal injury, death, or product failure.

Mercury recommends using original Mercury Precision replacement parts and lubricants.

## EPA Emissions Regulations

All new outboards manufactured by Mercury Marine are certified to the United States Environmental Protection Agency, as conforming to the requirements of the regulations for the control of air pollution from new outboard motors. This certification is contingent on certain adjustments set to factory standards. For this reason, the factory procedure for servicing the product must be strictly followed and, wherever practicable, returned to the original intent of the design. **Maintenance, replacement, or repair of the emission control devices and systems may be performed by any marine spark ignition (SI) engine repair establishment or individual.**

# MAINTENANCE

## EMISSION CERTIFICATION LABEL

An emission certification label, showing emission levels and engine specifications directly related to emissions, is placed on the engine at time of manufacture.

		<b>EMISSION CONTROL INFORMATION</b>	
THIS ENGINE CONFORMS TO <input type="checkbox"/> CALIFORNIA AND U.S. EPA EMISSION REGULATIONS FOR SPARK IGNITION MARINE ENGINES			
REFER TO OWNERS MANUAL FOR REQUIRED MAINTENANCE SPECIFICATIONS AND ADJUSTMENTS			
<b>a</b> →	IDLE SPEED (in gear) : <input type="text"/>	FAMILY: <input type="text"/>	<b>f</b> →
<b>b</b> →	<input type="text"/> hp	<input type="text"/> cc	<b>g</b> →
<b>c</b> →	TIMING (IN DEGREES): <input type="text"/>		<b>h</b> →
<b>d</b> →	<input type="text"/>	SPARK PLUG : <input type="text"/>	<b>i</b> →
		GAP : <input type="text"/>	
<b>e</b> →	COLD VALVE CLEARANCE (mm) : <input type="text"/>	INTAKE : <input type="text"/>	
		EXHAUST : <input type="text"/>	

ob00366

- |  |  |
|--|--|
| <b>a</b> - Idle speed                      | <b>f</b> - Family number                                 |
| <b>b</b> - Engine horsepower               | <b>g</b> - Maximum emission output for the engine family |
| <b>c</b> - Piston displacement             | <b>h</b> - Timing specification                          |
| <b>d</b> - Date of manufacture             | <b>i</b> - Recommended spark plug and gap                |
| <b>e</b> - Valve clearance (if applicable) |  |

## OWNER RESPONSIBILITY

The owner/operator is required to have routine engine maintenance performed to maintain emission levels within prescribed certification standards.

The owner/operator is not to modify the engine in any manner that would alter the horsepower or allow emissions levels to exceed their predetermined factory specifications.

## Inspection And Maintenance Schedule

### PRIOR TO EVERY USE

- Check that lanyard stop switch stops the engine.
- Check steering system for binding or loose components.
- Check the outboard for tightness on transom.
- Check propeller blades for damage.
- Visually inspect all hoses, clamps, fittings, tubing, sealing gaskets, and mounting hardware for wear.

# MAINTENANCE

## AFTER EACH SALTWATER OR POLLUTED WATER USE

- Flush all internal passages with fresh water.
- Wash the power package exterior (cowl, mid section, and gearcase) with fresh water.
- Flush the propeller and gearcase exhaust outlet with fresh water.
- Remove the cowl and wipe off any saltwater spray with a damp cloth.

## EVERY 25 HOURS OR EVERY 30 DAYS OF SALTWATER OR POLLUTED WATER USE

- Spray the powerhead and all external, unpainted metal surfaces (except anodes) with Corrosion Guard.

## EVERY 25 HOURS OR EVERY 30 DAYS, WHICHEVER OCCURS FIRST

- Visually inspect the front and side cowl latches for tightness. Tighten if necessary.
- Visually inspect the fuel and oil systems for deterioration or leaks.
- Visually check steering link rod fasteners for wear. Lubricate all components (refer to the **Installation Manual** for lubrication specifications). Check all attachment hardware for proper torque tightness.
- Check level and condition of gearcase lubricant.
- Check alternator belt tension.

## EVERY 50 HOURS OR ONCE A YEAR, WHICHEVER OCCURS FIRST

- Lubricate all lubrication points.
- Lubricate splines on the drive shaft.
- Lubricate entire length of drive shaft with anti-corrosion grease.
- Lubricate splines on the propeller shaft.
- Drain and replace gearcase lubricant.
- Check the spark plug gap. Clean and replace plugs if necessary.
- Inspect all belts, pulleys, and idler pulleys for deterioration.
- Check fuel pressure.
- Check control cable adjustments.
- Inspect battery.
- Check corrosion control anodes.
- Check tightness of bolts, nuts and other fasteners.
- Check power trim fluid.



# MAINTENANCE

- Remove engine deposits with Power Tune Engine Cleaner.

## EVERY 100 HOURS OR ONCE A YEAR, WHICHEVER OCCURS FIRST

- Replace water pump impeller (more often if overheating occurs or reduced water pressure is noted).<sup>1</sup>
- Use QuickKleen in fuel.

## EVERY 100 HOURS OF OPERATION

- Inspect Carbon Fiber reeds for chipping or cracks.

## EVERY 200 HOURS OR ONCE EVERY TWO YEARS, WHICHEVER OCCURS FIRST

- Replace water separating fuel filter.
- Check the spark plug gap and replace if necessary.

## BEFORE PERIODS OF STORAGE

- Refer to **Storage** section.

## Flushing the Cooling System (Powerhead)

Flush the internal water passages of the engine with fresh water after each use in salt, polluted or muddy water. This will help prevent a buildup of deposits from clogging the internal water passages.

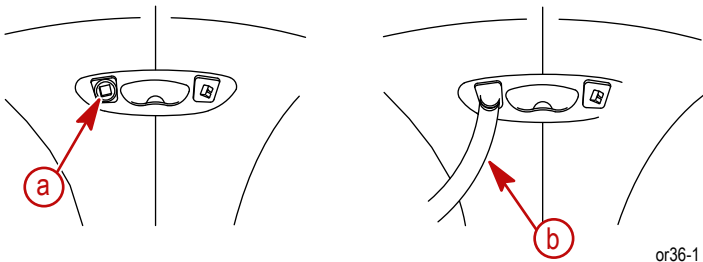

**a** - Plug located on fitting

**b** - Water hose

1. Remove the plug from fitting in the bottom cowl.
2. Attach a water hose to the fitting. Turn on the water and flush for three to five minutes.

**NOTE:** The engine can be stopped or operated at idle speed when flushing the cooling system. Do not flush engine using a water system that exceeds 310 kPa (45 psi).

1. These items should be serviced by a authorized dealer.

# MAINTENANCE

## Flushing the Cooling System (Lower Unit)

### ⚠ WARNING

To avoid possible injury when flushing, remove the propeller. Refer to Propeller Replacement.

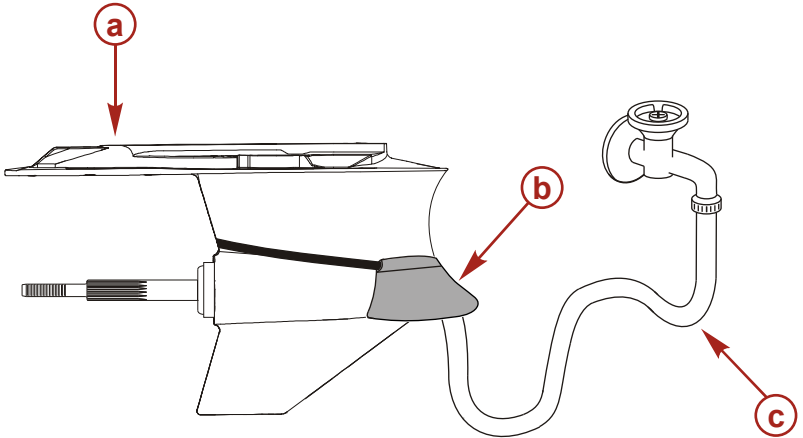

16100

**a** - Sport Master gearcase

**c** - Fresh water source

**b** - Flushing attachment

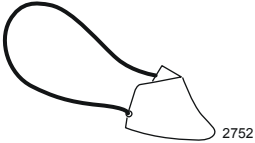
Flushing Attachment	848998A 1
	Attaches to the gearcase low water pick-ups, providing a fresh water connection when flushing the cooling system or operating the engine.

1. Remove the propeller. Refer to **Removing the Propeller** for more information.
2. Install the flushing attachment so the nose cone cup fits tightly over the intake holes.
3. Attach a water hose to the flushing attachment. Turn on the water and adjust the flow so water is leaking around the nose cone cup to ensure the engine receives an adequate supply of cooling water.
4. Start the engine and run it at idle speed in neutral shift position.

# MAINTENANCE

5. Adjust water flow so excess water continues leaking out from the nose cone cup.
6. Check for water coming out of the water pump indicator hole. Continue flushing for three to five minutes, carefully monitoring water supply at all times.
7. Stop the engine, turn off the water, and remove the flushing attachment.
8. Re-install the propeller.

## Top Cowl Removal and Installation

### REMOVAL

Release the front and side cowl latches. Lift the top cowl from the outboard.

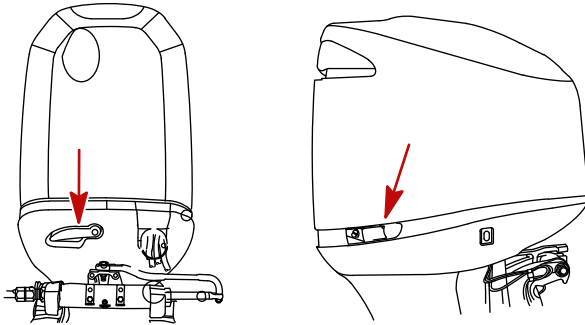

or38

### INSTALLATION

Position the top cowl over the engine. Make sure the bottom rubber seal fits properly and lock the front and side latches.

## Cleaning Care for Top Cowl

**IMPORTANT:** Dry wiping (wiping the plastic surface when it is dry) will result in minor surface scratches. Always wet the surface before cleaning. Follow cleaning and waxing procedure.

### CLEANING AND WAXING PROCEDURE

1. Before washing, rinse the top cowl with clean water to remove dirt and dust that may scratch the surface.
2. Wash the top cowl with clean water and a mild non-abrasive soap. Use a soft clean cloth when washing.
3. Dry thoroughly with a soft clean cloth.

# MAINTENANCE

4. Wax the surface using a non-abrasive automotive polish (polish designed for clear coat finishes). Remove the applied wax by hand using a clean soft cloth.

## Fuel System

### FUEL SYSTEM SERVICE INFORMATION

#### WARNING

Avoid serious injury or death from gasoline fire or explosion. Carefully follow all fuel system service instructions. Always stop the engine and do not smoke or allow open flames or sparks in the area while servicing any part of the fuel system.

**IMPORTANT:** Use an approved container to collect and store fuel. Wipe up any spillage immediately. Material used to contain spillage must be disposed of in an approved receptacle.

Before servicing any part of the fuel system:

- Stop engine and disconnect the battery.
- Drain the fuel system completely.
- Perform fuel system service in a well ventilated area.
- Inspect any completed service work for sign of fuel leakage.

### FUEL LINE INSPECTION

Visually inspect the fuel line and primer bulb for cracks, swelling, leaks, hardness, or other signs of deterioration or damage. If any of these conditions are found, the fuel line or primer bulb must be replaced.

### WATER SEPARATING FUEL FILTER

This filter removes moisture and debris from the fuel. If the filter becomes filled with water, the water can be removed. If the filter becomes plugged with debris, replace the filter. The warning system engages when water in the fuel filter reaches the full level. Refer to **Warning System** in **Features & Controls**.

Refer to the **Inspection and Maintenance Schedule** for the proper maintenance interval.

# MAINTENANCE

## Removal

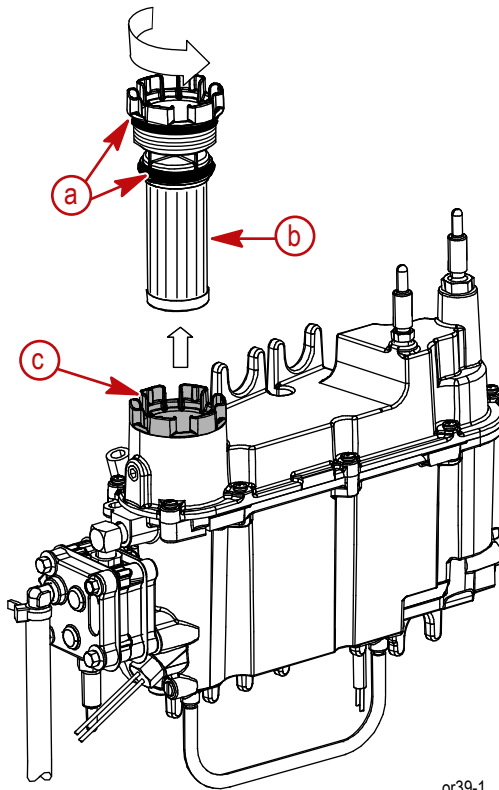

or39-1

- a** - O-ring seals
- b** - Filter
- c** - Raised bosses

1. Disconnect the link rod.
2. Use the shaft of a screwdriver between the filter cap bosses and unscrew the filter.

## Installation

1. Lubricate the o-ring seals with oil.
2. Install the fuel filter and tighten securely.
3. Reconnect the link rod.

**IMPORTANT:** Visually inspect for fuel leakage from the filter while squeezing the primer bulb until firm, forcing fuel into the filter.

# MAINTENANCE

## DRAINING WATER FROM THE FUEL FILTER CHAMBER

**NOTE:** If a sufficient amount of water has accumulated in the fuel filter chamber, the warning system will turn on. Draining the water from the fuel filter chamber is required.

1. Pull the drain hose off the right side fitting. Hold open end of the hose over a container.
2. Loosen drain screw and drain the fuel filter chamber.

**NOTE:** If little or no liquid drains from the hose, loosen the red filter to vent the chamber.

3. Retighten drain screw and reattach hose.

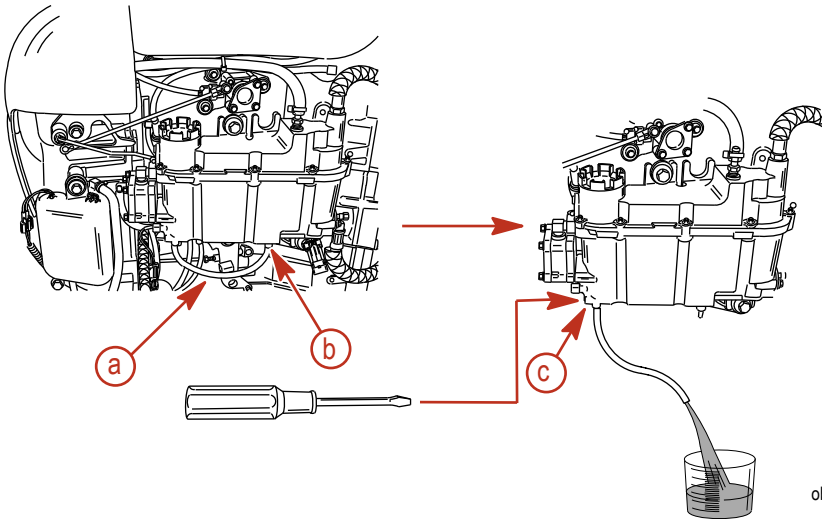

- a** - Drain hose
- b** - Side fitting
- c** - Drain screw

**IMPORTANT:** Visually inspect for fuel leakage from the drain screw by squeezing the primer bulb until firm, forcing fuel into the chamber.

## Steering Link Rod Fasteners

**IMPORTANT:** The steering link rod that connects the steering cables to the engine must be fastened using special washer head bolt (P/N 10-849838) and self-locking nylon insert locknuts (P/N 11-826709113). Never replace locknuts with common nuts (non-locking) as they will work loose/vibrate off freeing link rod to disengage.

# MAINTENANCE

## ⚠ WARNING

Disengagement of a steering link rod can result in the boat taking a full, sudden, sharp turn. This potentially violent action can cause occupants to be thrown overboard exposing them to serious injury or death.

## ⚠ WARNING

Avoid equipment damage, serious injury or death. Visually inspect all steering attachment components for wear, lubricate all attachment hardware, and check for proper torque tightness in accordance with the inspection and maintenance schedule.

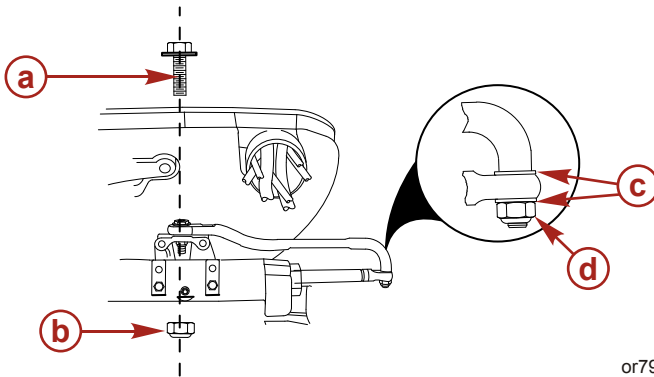

**a** - Special washer head bolt  
(P/N 10-849838)

**b** - Nylon Locknut - used on  
head bolt (P/N  
11-826709113)

**c** - Flat washer (2)

**d** - Nylon Locknut - used on  
cable coupler (P/N  
11-826709113)

or79

1. Assemble steering link rod to steering cable coupler with two flat washers "c" and a self-locking nylon insert locknut "d." Tighten the locknut until it seats, then loosen  $\frac{1}{4}$  turn.
2. Assemble the steering link rod to the engine with the special washer head bolt "a" and self locking nylon insert locknut "b."
3. Torque the head bolt, then the locknut to specifications.

Description	Nm	lb. in.	lb. ft.
Cable Coupler Nylon Locknut "d"	Tighten locknut until it seats, then loosen $\frac{1}{4}$ turn.		
Head Bolt Nylon Locknut "b"	27		20

# MAINTENANCE

Description	Nm	lb. in.	lb. ft.
Special washer head bolt	27		20

## Fuses

**IMPORTANT: Always carry spare 5 and 20 amp fuses.**

The electrical wiring circuits on the engine are protected from overload by fuses in the wiring. If a fuse is blown, try to locate and correct the cause of the overload. If the cause is not found, the fuse may blow again.

1. Open the fuse holder and look at the silver colored band inside the fuse. If band is broken, replace the fuse.
2. Replace fuse with a new fuse with the same rating.

The fuses and circuits are identified as follows:

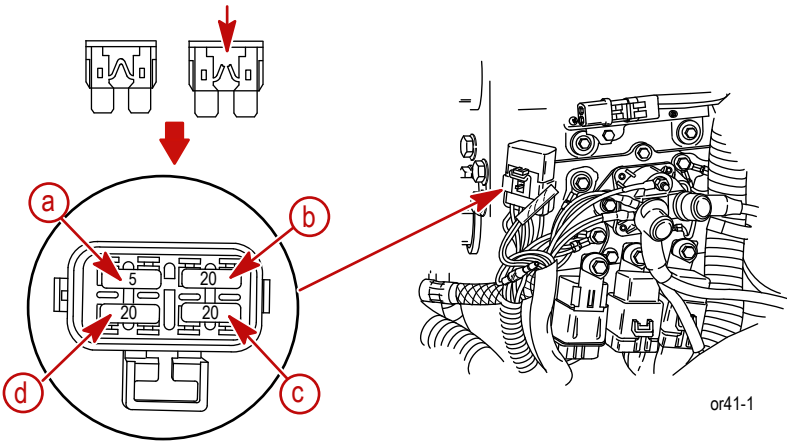

**a** - SmartCraft data bus circuit - 5 amp fuse

**b** - Accessories - 20 amp fuse

**c** - Ignition Coil Circuit - 20 amp fuse

**d** - Electric fuel pump/ECM driver power/Oil pump circuit SFE 20 amp fuse



# MAINTENANCE

## Corrosion Control Anode

### ⚠ CAUTION

Avoid corrosion damage. Mercury Marine recommends using anodes sold through Mercury Precision Parts only. Some other manufacturers of aluminum anodes use alloys that are insufficiently pure to adequately protect critical drive components for the duration of the anodes' expected life.

Anodes help protect the power package against galvanic corrosion by sacrificing its metal to be slowly eroded instead of other metals.

This model has three corrosion control anodes—two above and one below the anti-ventilation plate. A fourth anode is located on the bottom of the clamp/swivel bracket assembly.

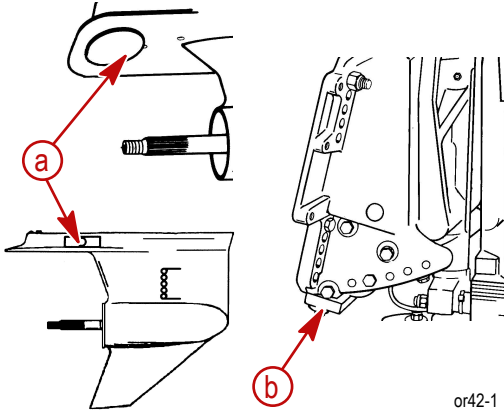

- a** - Corrosion control anodes (three on gearcase)
- b** - Corrosion control anode (one on clamp/swivel bracket)

All anodes require periodic inspection, especially in salt water (refer to the **Inspection and Maintenance Schedule**). Replace any anodes before they are 50% corroded. Never paint or apply protective coating on the anode, as effectiveness of the anode will be reduced.

# MAINTENANCE

## Spark Plug Inspection and Replacement

### ⚠ WARNING

Avoid serious injury or death from fire or explosion caused by damaged spark plug boots. Damaged spark plug boots can emit sparks. Sparks can ignite fuel vapors under the engine cowl. To avoid damaging spark plug boots, do not use any sharp object or metal tool such as pliers, screwdriver, etc. to remove spark plug boots.

1. Remove the spark plug leads. Twist the rubber boots slightly and pull off.

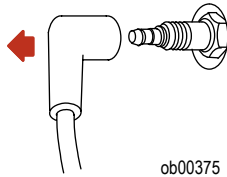

2. Remove the spark plugs to inspect. Replace spark plug if electrode is worn or the insulator is rough, cracked, broken, or blistered, or if the precious metal is not visible on the plug's electrode.

**IMPORTANT:** The color of the plug may not accurately reflect its condition. To accurately diagnose a faulty plug, inspect the precious metal on the plug's electrode. If no precious metal is visible, replace the plug.

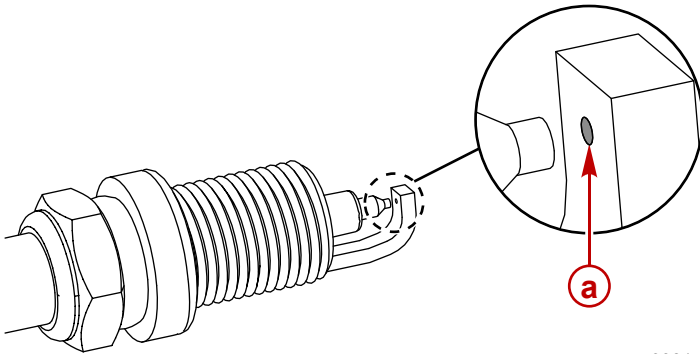

**a** - Precious metal

9381

# MAINTENANCE

3. Set the spark plug gap to specifications.

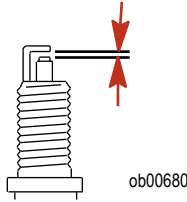

<b>Spark Plug Gap</b>	0.81 mm (0.032 in.)
-----------------------	---------------------

4. Before installing spark plugs, clean off any dirt on the spark plug seats. Install plugs finger tight, and then tighten 1/4 turn or torque to specifications.

Description	Nm	lb. in.	lb. ft.
Spark plug	27		20

## Battery Inspection

The battery should be inspected at periodic intervals to ensure proper engine starting capability.

**IMPORTANT: Read the safety and maintenance instructions which accompany your battery.**

1. Turn off the engine before servicing the battery.
2. Add water as necessary to keep the battery full.
3. Make sure the battery is secure against movement.
4. Battery cable terminals should be clean, tight, and correctly installed. Positive to positive and negative to negative.
5. Make sure the battery is equipped with a nonconductive shield to prevent accidental shorting of battery terminals.

# MAINTENANCE

## Charging System Fusible Link

This model has a 100 ampere fusible link between the alternator and the +12 volt stud. This fusible link protects the alternator from damage due to accidental reverse battery connection. If the battery cables are reversed, the fusible link creates an open circuit, protecting the alternator. With the fusible link open, the engine can be started; however, the run time is limited, because the alternator is not charging the boat battery. If the fusible link circuit becomes open, contact your authorized Mercury Marine dealer.

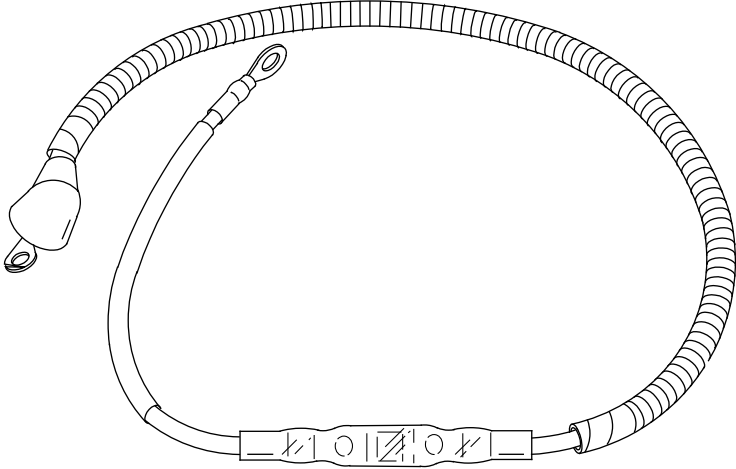

59364

## Removing the Propeller

### **⚠ WARNING**

**Avoid possible serious injury or death. Shift the outboard to the neutral position and remove spark plug leads before servicing the propeller. If the propeller is rotated while the engine is in gear, the engine could start and, therefore, create a hazardous condition.**

**NOTE:** *If propeller is seized to the shaft and cannot be removed, consult your authorized Mercury Marine dealer.*

# MAINTENANCE

1. Shift outboard to neutral.

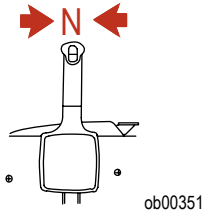

2. Remove the spark plug leads to prevent the engine from starting.

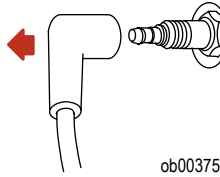

3. Straighten the bent tabs on the propeller nut retainer (if applicable).
4. Place a block of wood between the gearcase and the propeller to hold the propeller and remove the propeller nut.

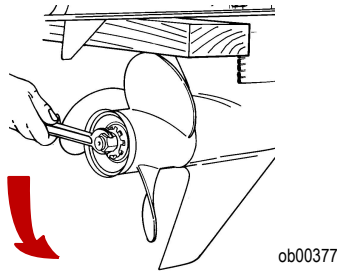

5. Remove the propeller and associated hardware from the propeller shaft.

## Installing the Propeller (19 Spline Shafts)

### **⚠ WARNING**

Avoid serious personal injury or death. Remove the key from the ignition switch, disconnect the lanyard stop switch, and remove the spark plug leads to ensure that the engine does not accidentally start.

# MAINTENANCE

## ⚠ CAUTION

Avoid engine damage. Prop the engine so engine speed is limited to the required full throttle rpm range. An under-propped engine may occasionally initiate the rev limiter. This may result in internal powerhead damage.

Applications using 19 spline propeller shafts require the Heavy-Duty Propeller Hub kit, included with most Mercury Racing propellers.

Before installing the propeller:

1. Set the remote control into the neutral position.
2. Remove the keys from the ignition and engage the safety stop switch.
3. Coat the propeller shaft with Anti-Corrosion Grease.

**IMPORTANT:** To prevent the propeller hub from corroding and seizing to the propeller shaft, especially in salt water, always apply a coat of the recommended lubricant to the entire propeller shaft at the recommended maintenance intervals and also each time the propeller is removed.

To install a propeller for use with a 19 spine propeller shaft:

1. Lubricate the propeller shaft splines.
2. Install the propeller hub assembly, propeller, washer, Belleville washer, washer, and propeller nut onto the propeller shaft.

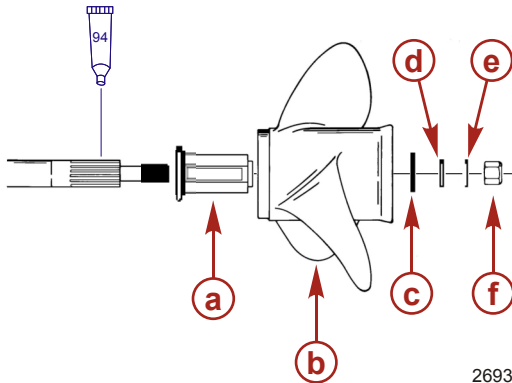

2693

**a** - Propeller hub assembly

**b** - Propeller

**c** - Washer

**d** - Belleville washer

**e** - Washer

**f** - Propeller nut

# MAINTENANCE

Tube Ref No.	Description	Where Used	Part No.
	Anti-Corrosion Grease	Propeller shaft splines	92-802867A 1

- Place a block of wood between the gearcase and propeller and torque the propeller nut.

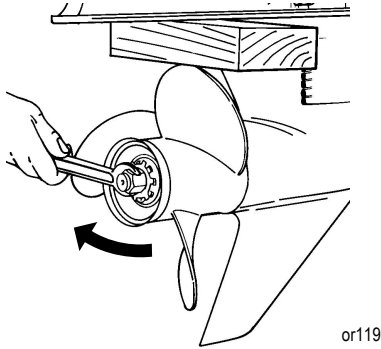

Description	Nm	lb. in.	lb. ft.
Propeller nut	75		55



- Place the safety stop switch into the "RUN" position.

# MAINTENANCE

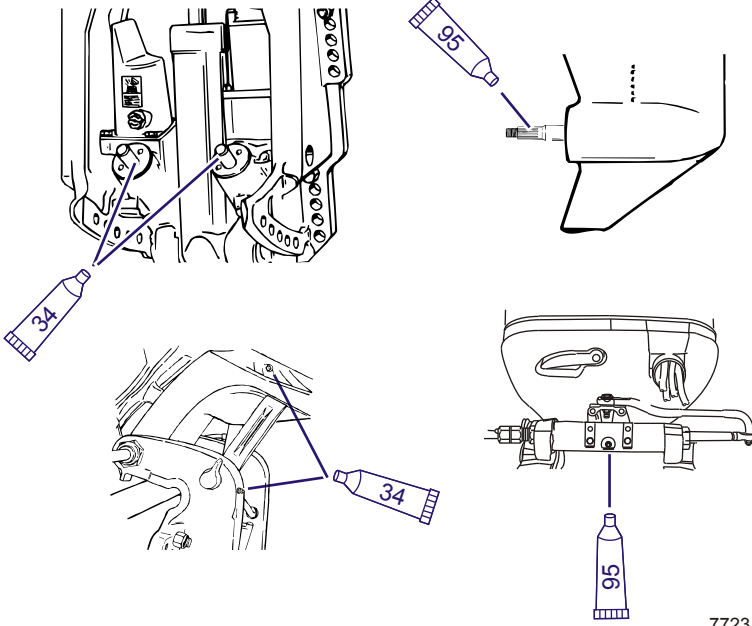
## Lubrication Points



7723

Tube Ref No.	Description	Where Used	Part No.
 34	Special Lubricant 101	Trim Rod Ball Ends	92-802865A1
 95	2-4-C Marine Lubricant with Teflon	Prop Shaft, Swivel Bracket, Tilt Support Lever, Tilt Tube	92-802859A1

**NOTE:** Turn the ball ends to work the lubricant into the ball sockets. Lubricate through fittings.





# MAINTENANCE

## ⚠ WARNING

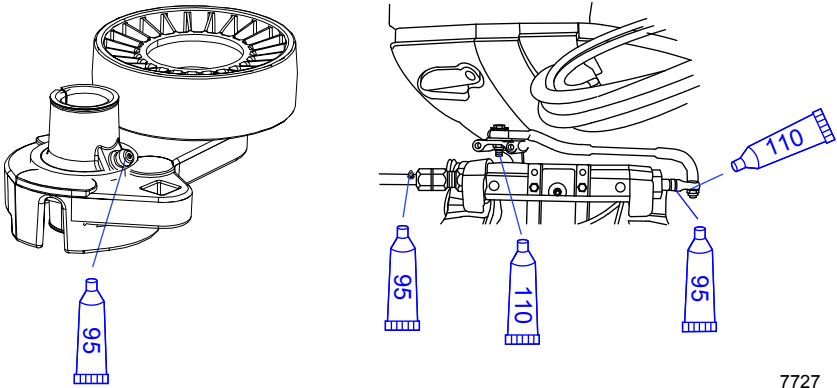
The end of the steering cable must be fully retracted into the outboard tilt tube before adding lubricant. Adding lubricant to steering cable when fully extended could cause steering cable to become hydraulically locked. A hydraulically locked steering cable will cause loss of steering control, possibly resulting in serious injury or death.



7727

Tube Ref No.	Description	Where Used	Part No.
	2-4-C Marine Lubricant with Teflon	Steering cable and grease fitting on belt tensioner pulley	92-802859A1
	4 Stroke 10W30 Outboard Oil	Steering cable	92-802833A1

## Checking Trim System Fluid Level

### ⚠ CAUTION

Avoid possible injury. Oil in the trim system is under pressure when the outboard is in any position other than the full tilt position. Position the outboard in the full tilt position before opening the fill cap.

# MAINTENANCE

1. Tilt the outboard to the full up position and engage the tilt support lever.

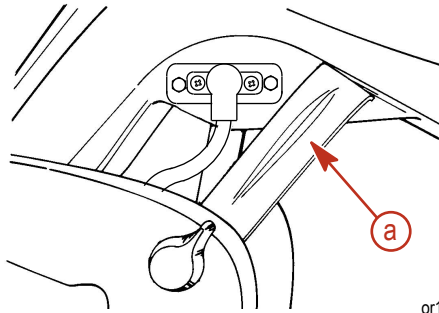

or113

**a** - Tilt support lever

2. Remove the fill cap and check the fluid level, which should be even with the bottom of the fill hole. If necessary, add Power Trim & Steering Fluid. If this is not available, use automotive transmission fluid (ATF).

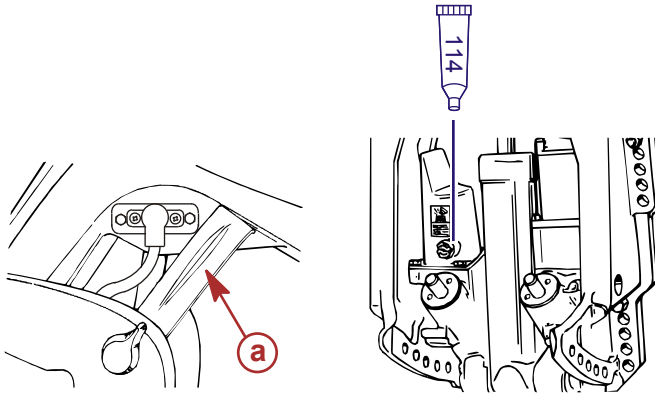

7729

**a** - Fill cap

Tube Ref No.	Description	Where Used	Part No.
 114	Power Trim and Steering Fluid	Trim system fill hole	92-802880A 1

3. Re-install the fill cap.
4. Trim the outboard through the entire trim and tilt range several times to remove any air from the system.

# MAINTENANCE

## Gearcase Lubricant

### CHECKING/REFILLING GEARCASE LUBRICANT

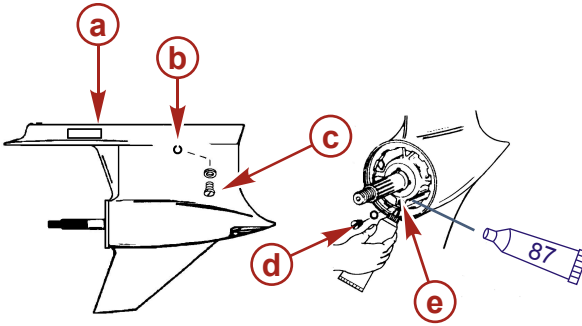

16102

- a** - SportMaster gearcase (vertical operating position)
- b** - Vent hole
- c** - Vent plug and sealing washer
- d** - Fill/drain plug
- e** - Fill/drain hole

Tube Ref No.	Description	Where Used	Part No.
	High Performance Gear Lubricant	Fill/Drain Hole	92-802854A1

1. Place the outboard in a vertical operating position.
2. Remove the vent plug (upper plug) and sealing washer.
3. Remove the fill/drain plug (lower plug).
4. Quickly place lubricant tube into the fill hole.
5. Slowly add lubricant until it flows from the (upper) vent hole.
6. Stop adding lubricant. Install the (upper) vent plug and sealing washer before removing the lubricant tube.

**IMPORTANT: Replace sealing washers if damaged.**

**NOTE:** Examine the magnetic fill/drain plug for metal particles. A small amount of metal filings or fine metal particles indicates normal gear wear. An excessive amount of metal filings or larger particles (chips) should be checked by an authorized dealer.

7. Remove lubricant tube and reinstall cleaned (lower) fill/drain plug and sealing washer.

# MAINTENANCE

## Water in gear lubricant may:

- Settle to bottom and drain out with the lubricant
- Be mixed with lubricant giving a milky color to lubricant

## Water in gear lubricant will:

- Result in premature bearing failure
- In freezing temperatures, turn to ice and damage gearcase

## DRAINING THE GEARCASE

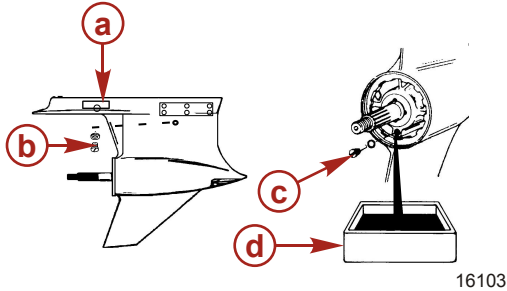

**a** - SportMaster Gearcase  
(vertical operating position)

**b** - Vent plug and sealing ring

**c** - Fill/Drain plug and sealing ring

**d** - Drain pan

1. Place the outboard in a vertical operating position.
2. Place a drain pan below outboard.
3. Remove the vent plug (upper plug) and sealing ring.
4. Remove the fill/drain plug (lower plug) and sealing ring and drain lubricant.

## GEARCASE LUBRICANT CAPACITY

Gearcase lubricant capacity is approximately 710 ml (24 oz).

# STORAGE

## Storage Preparation

The major consideration in preparing your outboard for storage is to protect it from rust, corrosion, and damage caused by freezing of trapped water.

The following storage procedures should be followed to prepare your outboard for out of season storage or prolonged storage (two months or longer).

### CAUTION

**Never start or operate your outboard (even momentarily) without water circulating through all the cooling water intake holes in the gearcase to prevent damage to the water pump (running dry) or overheating of the engine.**

## FUEL SYSTEM

**IMPORTANT:** Gasoline containing alcohol (ethanol or methanol) can cause a formation of acid during storage and can damage the fuel system. If the gasoline being used contains alcohol, it is advisable to drain as much of the remaining gasoline as possible from the fuel tank, remote fuel line, and engine fuel system.

The most effective method for storage preparation is to add the recommended amount of Mercury Precision Fuel Stabilizer and Mercury Precision Quickleen products as described on their containers to the fuel tank before the last operation of the boat. Adding Fuel Stabilizer will help prevent the formation of varnish and gum in the gasoline. The Mercury Precision Quickleen product will help clean and lubricate the fuel injectors.

1. Portable Fuel Tank - Pour the required amount of gasoline stabilizer (follow instructions on container) into fuel tank. Tip fuel tank back and forth to mix stabilizer with the fuel.
2. Permanently Installed Fuel Tank - Pour the required amount of gasoline stabilizer (follow instructions on container) into a separate container and mix with approximately one quart (one liter) of gasoline. Pour this mixture into fuel tank.
3. Pull the drain hose off the right side fitting. Hold the open end of the hose over a container. Loosen drain screw and drain the fuel filter chamber.

# STORAGE

**NOTE:** If little or no liquid drains from the hose, loosen the red filter to vent the chamber.

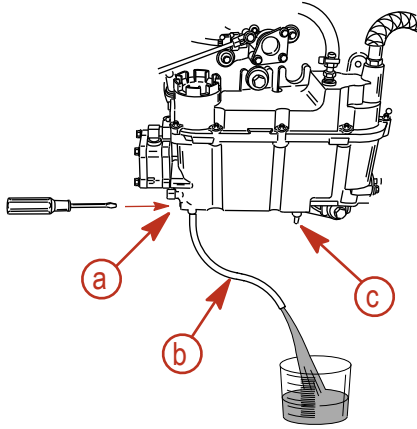

ob01352

- a** - Drain screw
- b** - Drain hose
- c** - Right side fitting

4. Re-tighten drain screw and re-attach hose.
5. Pull the drain hose off the left side fitting. Hold the open end of the hose over a container and loosen drain screw and drain the float chamber. Re-tighten drain screw and re-attach hose.

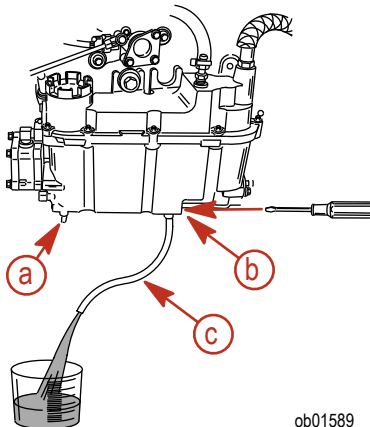

ob01589

- a** - Left side fitting
- b** - Drain screw
- c** - Drain hose

# STORAGE

6. Premix the following in a container:
  - 8 cc (0.27 oz.) or 2 teaspoons of Mercury Precision Quickleen lubricant.
  - 8 cc (0.27 oz.) or 2 teaspoons of Mercury Precision Fuel Stabilizer.
7. Remove the fuel filter. Refer to **Maintenance - Fuel System**.
8. Pour mixture into the fuel filter opening.
9. Reinstall the fuel filter.
10. Prime the fuel system as outlined in the **Operation - Starting the Engine**.
11. Place the outboard in water or use the flushing attachment for circulating cooling water. Start the engine and run at idle speed for 5 minutes to allow the treated fuel to fill the fuel system.

## Protecting Internal Engine Components

**NOTE:** Make sure the fuel system has been prepared for storage. Refer to **Fuel System**, preceding.

**IMPORTANT:** Refer to **Spark Plug Inspection and Replacement** for correct procedure for removing spark plug leads.

1. Remove the spark plugs and add approximately 30 ml (1 oz.) of engine oil into each spark plug hole.
2. Rotate the flywheel manually several times to distribute the oil in the cylinders.
3. Re-install spark plugs.

## Protecting External Outboard Components

- Lubricate all outboard components listed in **Maintenance - Inspection and Maintenance Schedule**.
- Touch up any paint nicks. See your dealer for touch-up paint.
- Spray Quicksilver or Mercury Precision Lubricants Corrosion Guard on external metal surfaces (except corrosion control anodes).

Tube Ref No.	Description	Where Used	Part No.
 120	Corrosion Guard	External metal surfaces	92-802878-5 5

## Gearcase

- Drain and refill the gearcase lubricant (refer to **Maintenance - Gearcase Lubrication**).

# STORAGE

## Positioning Outboard For Storage

Store outboard in an upright (vertical) position to allow water to drain out of outboard.

### CAUTION

If outboard is stored tilted up in freezing temperature, trapped cooling water or rain water that may have entered the propeller exhaust outlet in the gearcase could freeze and cause damage to the outboard.

## Battery Storage

- Follow the battery manufacturer's instructions for storage and recharging.
- Remove the battery from the boat and check water level. Recharge if necessary.
- Store the battery in a cool, dry place.
- Periodically check the water level and recharge the battery during storage.



# TROUBLESHOOTING

## Starter Motor Will Not Crank the Engine

### POSSIBLE CAUSES

- Blown 20 amp fuse in the starting circuit. Refer to **Maintenance**.
- Outboard is not shifted to neutral position.
- Weak battery or battery connections are loose or corroded.
- Ignition key switch failure.
- Wiring or electrical connection faulty.
- Starter motor solenoid or slave solenoid failure.

## Engine Will Not Start

### POSSIBLE CAUSES

- Lanyard stop switch not in "RUN" position.
- Battery not fully charged.
- Incorrect starting procedure. Refer to **Operation** section.
- Old or contaminated fuel.
- Fuel is not reaching the engine.
  - Fuel tank is empty.
  - Fuel tank vent not open or restricted.
  - Fuel line is disconnected or kinked.
  - Primer bulb not squeezed.
  - Primer bulb check valve is faulty.
  - Fuel filter is obstructed. Refer to **Maintenance** section.
  - Fuel pump failure.
  - Fuel tank filter obstructed.
- Open 20 amp fuse. Check fuses, refer to **Maintenance** section.
- Threaded connection of an air hose is loose.
- Ignition system component failure.
- Spark plugs fouled or defective. Refer to **Maintenance** section.

## Engine Runs Erratically

### POSSIBLE CAUSES

- Spark plugs fouled or defective. Refer to **Maintenance** section.
- Incorrect setup and adjustments.
- Fuel is being restricted to the engine.
  - a. Engine fuel filter is obstructed. Refer to **Maintenance** section.

# TROUBLESHOOTING

- b. Fuel tank filter obstructed.
- c. Stuck anti-siphon valve on built in fuel tank.
- d. Fuel line is kinked or pinched.
- e. Injector plugged.
- Threaded connection of an air hose is loose.
- Fuel pump failure.
- Ignition system component failure.

## Performance Loss

### POSSIBLE CAUSES

- Throttle not opening fully.
- Damaged propeller or improper propeller size.
- Boat overloaded or load improperly distributed.
- Excessive water in bilge.
- Boat bottom is dirty or damaged.
- Warning horn failure.
- Engine block pressure sensor or coolant temperature sensor failure (Guardian is activated).
- Restricted fuel system or filter (loss of fuel or air pressure).

## Warning Horn Activates (With Power Loss)

### POSSIBLE CAUSES

- Intermittent horn sound:
  - The oil level in the engine-mounted oil reservoir tank is low. Refill the reservoir tank and the remote oil tank. Refer to **Fuel and Oil** for details.
  - Battery voltage is out of limits.
  - Throttle position sensor failure.
- Continuous horn sound:
  - The oil level in the engine-mounted oil reservoir tank is critically low. Refill the reservoir tank and the remote oil tank. Refer to **Fuel and Oil** for details.
  - The oil pump has failed, halting the oil supply to the engine.

# TROUBLESHOOTING

- Engine speed exceeds the maximum-allowable RPM. The system limits the engine to within the allowable range. If the overspeed condition continues, Guardian places the engine into power reduction. Overspeed may be caused by incorrect propeller pitch, engine height, trim angle, etc.
- High engine temperature or low block water pressure.
- Cooling system clogged.
- Incorrect transom height (water pickups not getting adequate water supply).

## Warning Horn Activates (No Power Loss)

### POSSIBLE CAUSES

- Warning horn activates on start up. This is normal operation.
- Water is detected in the water-separating fuel filter. Refer to **Maintenance** for procedures on removing water from the filter.

## Battery Will Not Hold Charge

### POSSIBLE CAUSES

- Battery connections are loose or corroded.
- Low electrolyte level in battery.
- Worn out or inefficient battery.
- Excessive use of electrical accessories.
- Defective rectifier, alternator, or voltage regulator.

# OWNER SERVICE ASSISTANCE

## Local Repair Service

Always return your outboard to your local authorized dealer should the need for service arise. Only he has the factory trained mechanics, knowledge, special tools, equipment, and genuine parts and accessories to properly service your engine should the need occur. He knows your engine best.

## Service Away From Home

If you are away from your local dealer and the need arises for service, contact the nearest authorized dealer. Refer to the Yellow Pages of the telephone directory. If, for any reason, you cannot obtain service, contact the nearest Mercury Marine Service Office.

## Parts And Accessories Inquiries

All inquiries concerning genuine replacement parts and accessories should be directed to your local authorized dealer. The dealer has the necessary information to order parts and accessories for you. When inquiring on parts and accessories, the dealer requires the model and serial number to order the correct parts.

## Service Assistance

Your satisfaction with your outboard product is very important to your dealer and to us. If you ever have a problem, question or concern about your outboard product, contact your dealer or any authorized Mercury Marine dealership. If additional assistance is required, take these steps.

1. Talk with the dealership's sales manager or service manager. If this has already been done, then contact the owner of the dealership.
2. Should you have a question, concern, or problem that cannot be resolved by your dealership, please contact Mercury Marine Service Office for assistance. Mercury Marine will work with you and your dealership to resolve all problems.

The following information will be needed by the service office:

- Your name and address
- Daytime telephone number
- Model and serial number of your outboard
- The name and address of your dealership
- Nature of problem

# OWNER SERVICE ASSISTANCE

## Mercury Marine Service Offices

For assistance, call, fax, or write. Please include your daytime telephone number with mail and fax correspondence.

<b>United States</b>		
Telephone	(920) 929-5040	Mercury Marine W6250 W. Pioneer Road P.O. Box 1939 Fond du Lac, WI 54936-1939
Fax	(920) 929-5893	
Website	www.mercurymarine.com	

<b>Canada</b>		
Telephone	(905) 567-6372	Mercury Marine Ltd. 2395 Meadowpine Blvd. Mississauga, Ontario L5N 7W6 Canada
Fax	(905) 567-8515	

<b>Australia, Pacific</b>		
Telephone	(61) (3) 9791-5822	Mercury Marine Australia 132-140 Frankston Road Dandenong, Victoria 3164 Australia
Fax	(61) (3) 9793-5880	

<b>Europe, Middle East, Africa</b>		
Telephone	(32) (87) 32 • 32 • 11	Marine Power - Europe, Inc. Parc Industriel de Petit-Rechain B-4800 Verviers, Belgium
Fax	(32) (87) 31 • 19 • 65	

<b>Mexico, Central America, South America, Caribbean</b>		
Telephone	(954) 744-3513	Mercury Marine 11650 Interchange Circle North Miramar, FL 33025 U.S.A.
Fax	(954) 744-3535	

<b>Japan</b>		
Telephone	81-053-423-2500	Mercury Marine - Japan Anshin-cho 283-1 Hamamatsu Shizuoka-ken, Japan 435-0005 Japan
Fax	81-053-423-2510	

## OWNER SERVICE ASSISTANCE

<b>Asia, Singapore</b>		
Telephone	5466160	Mercury Marine Singapore 72 Loyang Way Singapore, 508762
Fax	5467789	

### Ordering Literature

Before ordering literature, please have the following information about your power package available:

<b>Engine Model:</b>		<b>Horsepower:</b>	
<b>Serial Number:</b>		<b>Model year:</b>	

### UNITED STATES AND CANADA

For information on additional literature that is available for your particular Mercury/MerCruiser power package and how to order that literature contact your nearest dealer or contact:

<b>MERCURY MARINE</b>		
<b>Telephone</b>	<b>Fax</b>	<b>Mail</b>
(920) 929-5110	(920) 929-4894	Mercury Marine Attn: Publications Department P.O. Box 1939 Fond du Lac, WI 54936-1939 ,

### OUTSIDE THE UNITED STATES AND CANADA

Contact your nearest dealer or Marine Power Service Center for information on additional literature that is available for your particular Mercury/MerCruiser power package and how to order that literature.

