



ARVOR

**QUICKSILVER**<sup>®</sup>  
**CAPTUR**



## WELCOME TO THE CAPTUR RANGE FROM QUICKSILVER.

Captur gives you the freedom of the water, the freedom to fish and the freedom to be spontaneous. Perfect for friends and serious fishermen – they offer everything you could need and more.

From day trippers to overnights, these boats let you seek out life rather than just let it happen – to enjoy life to the full: carefree and worry-free. Boats with all the power, comfort and practicality to get you out there. Life is more fun when you remove the obstacles.

Life is for living, for remembering.  
It's a journey.

Seize the moment.

Explore our complete range of boats  
and dealer network now at  
[www.quicksilver-boats.com](http://www.quicksilver-boats.com)

**QUICKSILVER®**



Life is now



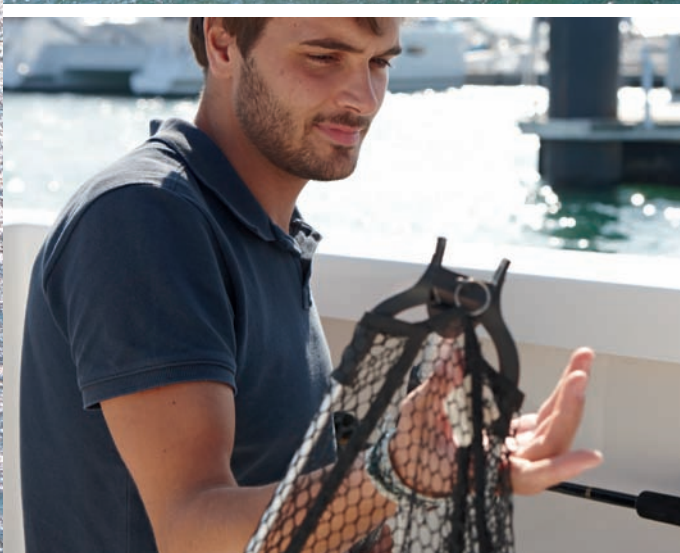

## CONTENT

Introduction Arvor _____	4
Mercury Diesel _____	5
<b>NEW CAPTUR 810 ARVOR</b> _____	<b>6</b>
CAPTUR 730 ARVOR _____	10
CAPTUR 690 ARVOR _____	14
Specifications & Packs _____	18



## ARVOR

This is the natural choice for fishing. A range of boats that combines reliability, practicality and technology to make all those trips memorable.

When it comes to power, you've got everything you need to get you there and back safely and smoothly. Solid diesel inboard engines blend higher displacement with the very latest advancements to deliver the performance, dependability and extreme trolling capability you need. Superior engine technology that also cuts fuel consumption and emissions.

For even greater reassurance, a low centre of gravity means a stable ride and position when you're fishing, while a transom door and high freeboards provide easy access getting in and around the boat. And to put you further at ease, the comfortable cabin includes a seating area that also turns into a berth.

You also get more space and fishing access aft – all helped by the propeller being neatly tucked away underneath. Add in rodholders, fish lockers, a cutting board and a livewell all as standard and there's nothing to get in the way of you and a great day's fishing.







## MERCURY DIESEL MORE TORQUE – LESS FUEL – IDEAL FOR FISHING

One of the key differences between a gas and diesel inboard engine is that diesels, while running at lower RPMs, have more pulling power than the gas counterparts. Up to 30% more torque, in fact.

For marine use, this makes diesels ideal for low-speed trolling – especially with multiple lines – allowing the boat to travel slowly and steadily without understressing the engine. Which means better control, less wear on the engine and less fuel consumption. All of which adds up to a reliable inboard power pack that will last longer and is cheaper to run. Plus, an inboard diesel gives better access to your transom area, and its deeper, more forward positioned propeller won't snarl your nets.

Mercury's range of robust and practical inboard diesels are the ideal answer to your every fishing need. Equipped with Common Rail Electronic Injection as well as a turbo-compressor, and fully compatible with Smart Craft Electronics, Mercury Diesel engines deliver quick response and superior performance and cruise power, but with excellent fuel economy. Plus, today's advanced technology means that our diesels have low emissions and quiet running.

Each Mercury Diesel engine that leaves the factory has undergone a series of rigorous tests to ensure quality, reliability and longevity, while ongoing maintenance is straightforward, thanks to the simple engine design and easily accessible service points.

With the world's largest dealer network, you can be sure that your local Mercury Marine dealer and service centre isn't far away.





# 810 ARVOR

## ALL YOU NEED FOR A GREAT FISHING EXPERIENCE - ANYTIME, ANYWHERE

For fishing enthusiasts looking for tradition mixed with performance and up-to-the minute comfort, the 810 Arvor is the perfect answer. Robust and practical, this heavy-duty fishing boat offers all the fishing features underpinned with the safety you need for both inshore and offshore fishing. The powerful Mercury inboard diesel is ideal for fishing. The trolling valve allows you to troll at low speed without creating extra wear on the engine. On board, the large fishing cockpit is complemented by the new pilothouse-style cabin and a bow area with plenty of comfortable seating. And after a great day of fishing you can cook your catch right out of the water with the LPG stove which comes as standard.



Length Overall (M)	8,30
Beam Maximum (M)	2,93
Height - Without Canvas (M)	3,40
Dry Weight (Kg)	2775
Fuel Capacity (L)	300
CE Design Category	B
Maximum Number of People	8
Maximum Power (HP/kW)	220/161





## SAFETY

With its robust hull design making it perfect for offshore and inshore use, the 810 Arvor also boasts a bow thruster that's great for precision manoeuvring in port. The port and starboard strong windscreen wipers and real glass windscreen make sure you have a 360° view in all weather conditions. The integrated helm with hydraulic steering, SmartCraft instrumentation and optional electronic pack with GSP/depth sounder make cruising and fishing as safe and easy as possible. Another safety feature is the improved non-skid walking surfaces throughout, which add to the safety together with the convenient grab rails that are placed throughout the boat.

## FISHING

The 810 Arvor offers a very large fishing cockpit with flip-down seating and a livewell, raw water washdown and bait preparation station. And, thanks to the LED cockpit lighting, you can now enjoy fishing day and night. The sturdy diesel engine with integrated trolling valve allows extreme slow trolling for hours without risk of damage to the engine or transmission and the extra rod holders and optional cockpit sun awning add to your fishing pleasure. An optional dual helm with electronic pack is offered for those that prefer to manoeuvre from the cockpit area while getting the boat on the exact location.

## COMFORT

The newly designed cabin contains both pilot and co-pilot seats, as well as a separated seating area. The cabin has sliding windows and a roof hatch, ensuring a light and airy feel inside. This sense of interior comfort is enhanced by the interior LED lighting and teak floor accents which add cosiness style. The dedicated galley with fresh water system, cutting board and LPG stove means you can cook up your catch and enjoy it straightaway. The seating area can be converted to a comfortable dining area for up to four persons or converted to a berth for 2.

## STORAGE

The 810 Arvor offers large cockpit floor storage and separate fish lockers to keep your catch. Rod storage is improved with both exterior rod storage in the cockpit and interior rod storage in the lockable cabin. In the cabin you will find ample storage place below the seating area and some dedicated storage in the galley. And to keep the mooring equipment tidy, you will find dedicated fender storage on the aft side of the boat.



# 810 ARVOR



7  
Large fishing cockpit



1 & 2

Large swimming platform  
Integrated fender storage on the aft

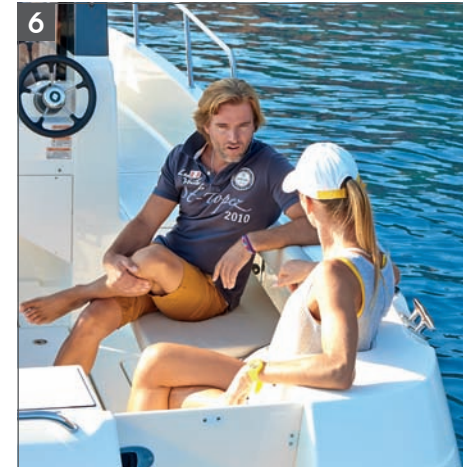

6  
Standard port & starboard flip down seat



4  
Livewell system with bait preparation station & raw water wash down



20

Optional second helm station with optional electronic pack



9 & 10

2 cabin seats with slide/swivel & flip-up bolsters  
Removable jump seat filler allows seating for third person





13

Dining area in cabin

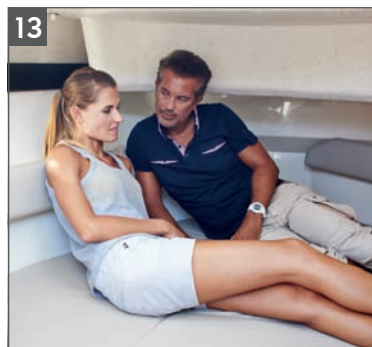

13

Double berth



17

Bow seat with cushion

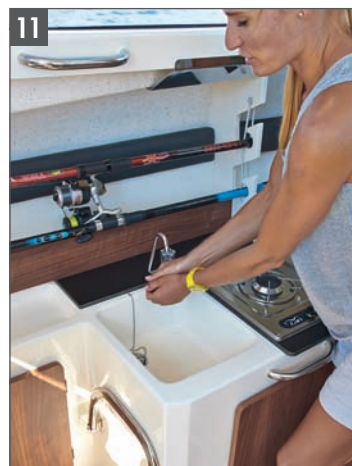

11

Galley with sink (cold water), cutting board and LPG stove

## MODEL FEATURES

1. Large swimming platform
2. Integrated fender storage on the aft
3. Wide Transom door
4. Livewell system with bait preparation station & raw water wash down
5. Corner seats
6. Standard port & starboard flip down seat
7. Large fishing cockpit
8. Sliding cabin entry door
9. 2 cabin seats with slide/swivel & flip-up bolsters
10. Removable jump seat filler allows seating for third person
11. Galley with sink (cold water), cutting board and LPG stove
12. Interior Rod Racks
13. Dining area that converts to double berth with storage below and berth cushions
14. Optional seawater toilet or enclosed seawater toilet
15. Integrated helm with hydraulic steering, SmartCraft instrumentation and optional 9" GPS
16. Large glass windscreen for good visibility with port and starboard windscreen wiper
17. Bow seat with cushion
18. Foredeck anchor locker and forward windlass
19. Large access walkway to foredeck
20. Optional second helm station with optional electronic pack

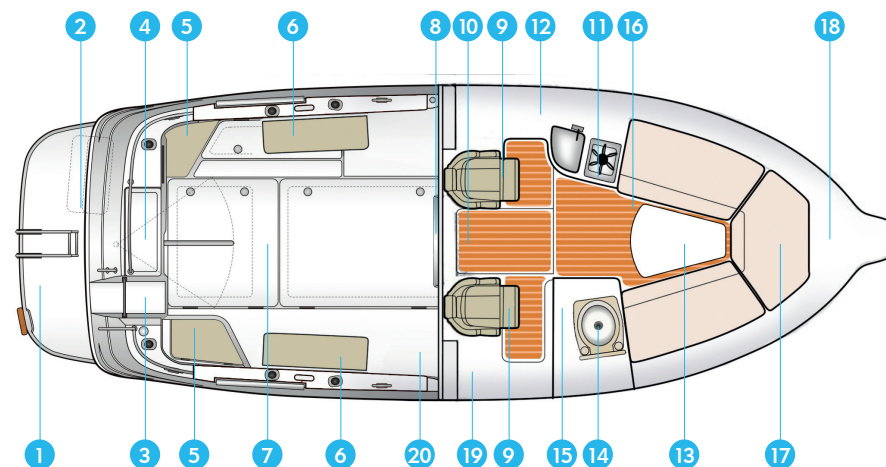



# 730 ARVOR

## NOW YOU CAN HAVE THE BEST OF BOTH WORLDS

For those who love their fishing, but also want to have fun, the new 730 Arvor promises an experience that has never been better. Combining the secure, seamanlike values of the Arvor hull with a modern pilot house cabin with 360° visibility and great comfort features, the new Arvor range offers literally the best of both worlds. Powered by an inboard Mercury Diesel 150hp, these craft can motor at trolling speed for hours, and they're also quick enough to get from place to place at speeds of up to 25 knots, putting you firmly on course for what must be the best fishing experience available in this category.



Length Overall (M)	7,30
Beam Maximum (M)	2,78
Height - Without Canvas (M)	3,03
Dry Weight (Kg)	1950
Fuel Capacity (L)	200
CE Design Category	C
Maximum Number of People	7
Maximum Power (HP/kW)	150/110





## SAFETY

A tried and tested profile, the Arvor offers robust manoeuvring capacities and excellent sea handling. Its larger cockpit has been remodelled to offer better access to and from the water, with a high freeboard to ensure your safety in the cockpit a wider transom door that allow you to get on and off the boat either from the quay or the water in complete safety and comfort. At the helm you have a 360° visibility and dual wipers, while the walk-around access and bow rails ensure total security up forward.

## FISHING

The cockpit is ideal for fishing and offers space for 4 persons to fish of. It is packed with a wealth of features - rodholders, livewell, fish lockers, cutting board- it's sure to bring a smile to every angler's lips. The 730 Arvor comes with the 150hp inboard Mercury Diesel engine with a trolling valve, which means you can troll for hours without understressing the engine, but you can also get to where the fish are a comfortable speed. And of course, the fresh water sink and butane stove in the cabin mean you can cook you catch at the end of the day.

## COMFORT

The 730 Arvor's roomy cabin just makes fishing all the more enjoyable. Comfortably sleeping two, its 360° visibility gives it a light and airy feel inside, while protecting you from the elements. The roof hatch and a sliding window offer extra ventilation, and the wider sliding door gives extra ease of access in and out. On deck, anti-skid surfaces at key points mean better manoeuvrability around the boat, and for the very best in navigation comfort, go for the optional dual helm station.

## STORAGE

Besides offering plenty of space, the new 730 Arvor also boasts plenty of storage. The cockpit rod storage keeps your fishing rods safe and out of the way. Lockers in the cockpit floor and additional space under the berth provide a variety of safe, accessible locations for you to keep all of the things you need for fishing and fun.



# 730 ARVOR

6



Large fishing cockpit

12



Integrated helm with hydraulic steering, SmartCraft instrumentation and optional 9" GPS and Bluetooth radio

4



Optional port flip down seat or rod storage rack for 3 rods

16



Access walkway to foredeck

3



Livewell with cutting board

Bow seat with cushion  
Foredeck anchor locker  
and forward windlass



14 & 15





10

Double berth with storage below and berth cushions



11

Optional seawater toilet



7

Sliding cabin entry door



9

Galley with cold water sink and portable butane stove

## MODEL FEATURES

1. Large swim platform
2. Walkthrough transom door
3. Livewell with cutting board
4. Optional port flip down seat or rod storage rack for 3 rods
5. Starboard flip down seat
6. Large fishing cockpit
7. Sliding cabin entry door
8. 2 cabin seats with slide/swivel & flip-up bolsters
9. Galley with cold water sink and portable butane stove
10. Double berth with storage below and berth cushions
11. Optional seawater toilet
12. Integrated helm with hydraulic steering, SmartCraft instrumentation and optional 9" GPS and Bluetooth radio
13. Large glass windscreen for good visibility with windscreen wiper
14. Bow seat with cushion
15. Foredeck anchor locker and forward windlass
16. Access walkway to foredeck

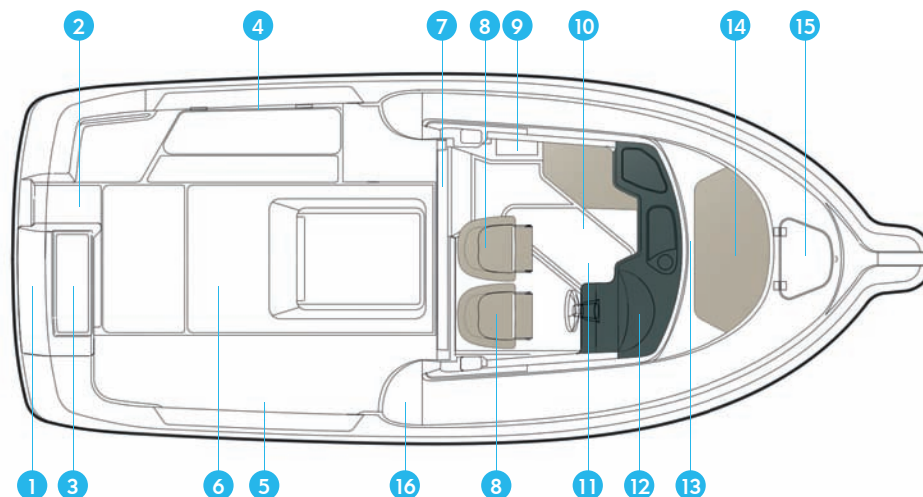



# 690 ARVOR

## FISHING HAS NEVER BEEN BETTER

For people who are serious about enjoying their fishing, the new 690 Arvor promises an experience that has never been better. Combining the well-known values of the Arvor with a modern pilot house with 360° visibility and great comfort features, the 690 Arvor offers literally the best of both worlds. Powered by Mercury Diesel inboard you can cruise at trolling speed for hours without any unnecessary wear on the engine. The 690 Arvor also has a top speed of over 21 knots.



Length Overall (M)	6,88
Beam Maximum (M)	2,54
Height - Without Canvas (M)	2,90
Dry Weight (Kg)	1740
Fuel Capacity (L)	90
CE Design Category	C
Maximum Number of People	6
Maximum Power (HP/kW)	115/84,6



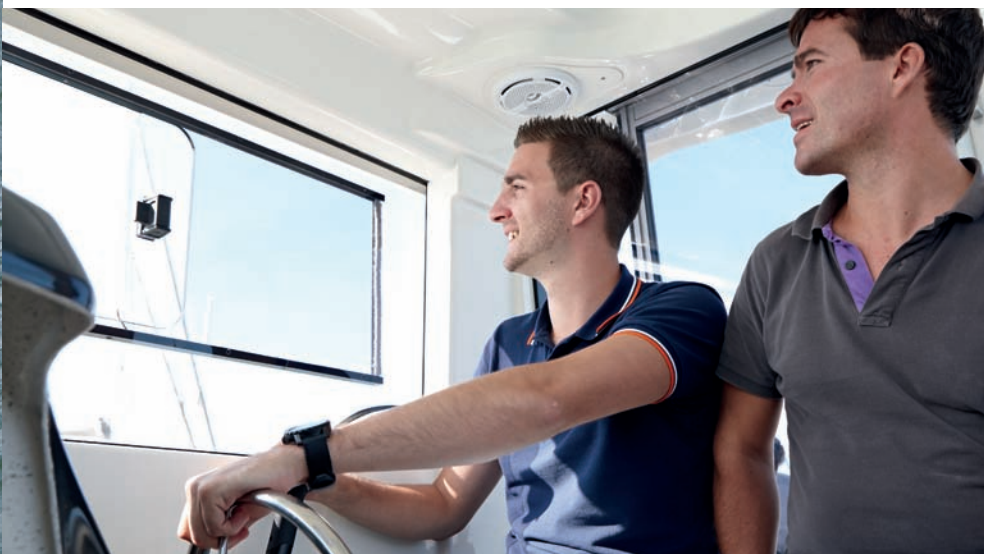
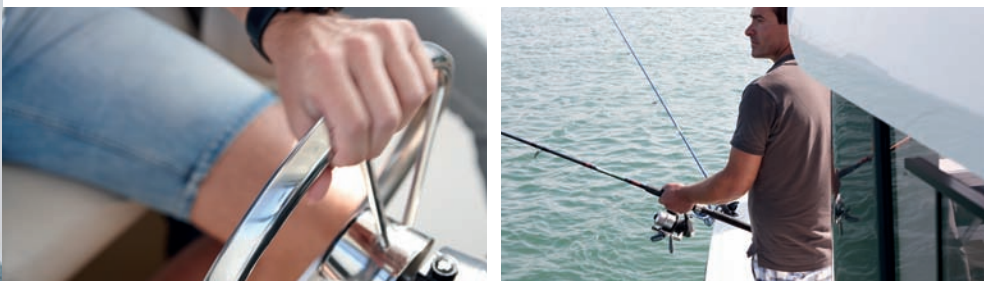

## SAFETY

The 690 Arvor offers a wealth of safety features that will allow you to fish and navigate with peace of mind. High cockpit freeboards, bow safety rails, and anti-skid surface, complemented by the new bow seating. And a 690 Arvor offers 360° visibility when you are at the helm, a large swim platform for easy access to the water and a transom door access that allow you to get on and off the boat either from the quay or the water in complete safety and comfort.

## FISHING

More than anything, the inboard Mercury Diesel engine is what makes the Arvor a real fishing boat. Because it's diesel, you can troll for hours with no extra engine wear, but it's also fast enough to get you to where the fish are at a handy 21 knots. An ample cockpit is packed with features to delight every angler – rod holders, livewell, fish lockers and cutting board– while the forward area also provides a stable fishing area. And of course, when you're done fishing, what could be better than brewing some fresh coffee in on the portable stove located in the cabin?

## COMFORT

Fishing is one thing, but fishing in comfort is altogether better. The 690 Arvor can comfortably sleep two. It has a roof hatch and a sliding window for extra ventilation, a wider sliding door for extra ease of access and an optional marine toilet. On deck, easy access from stern to bow is provided by a large pass on the starboard side, while up forward a new bow seating area allows for cruising and fishing in complete comfort. And for the very best in navigation comfort, the 690 Arvor offers an optional dual helm station.

## STORAGE

The 690 Arvor creates the space you need while offering plenty of storage. Improved rod storage will keep your fishing rods safe and secure. Lockers in the cockpit floor and storage under the berth provide a variety of safe, accessible locations for you to keep all of the things you need for fishing and fun.





9 Double berth with storage below and berth cushions



4

Optional port flip down seat or rod storage rack for 3 rods

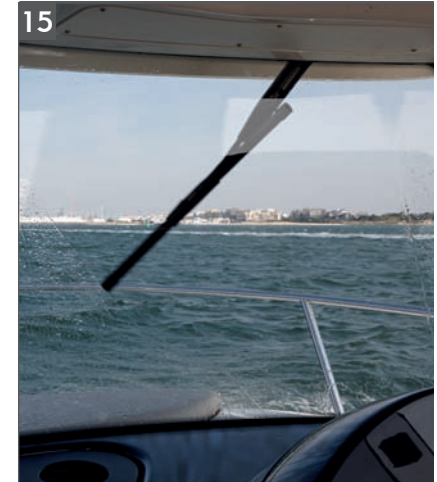

15

Large glass windscreen for good visibility with windscreen wiper



2

Walkthrough transom door



3

Livewell with cutting board

Starboard flip down seat

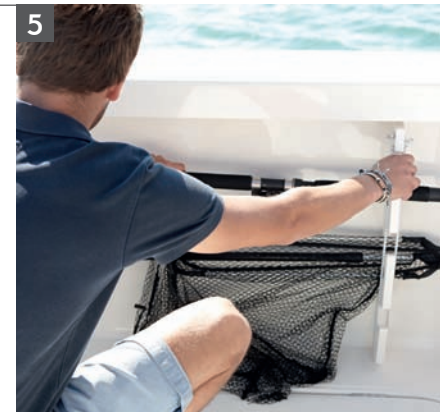

5





1

Large swim platform

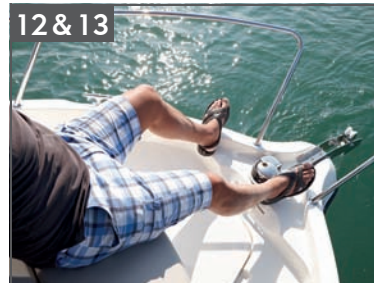

12 & 13

Bow seat with cushion  
Foredeck anchor locker  
and windlass



11

Integrated helm with hydraulic steering,  
SmartCraft instrumentation and  
optional 7" GPS and Bluetooth radio



8

2 cabin seats  
with slide/  
swivel & flip-up  
bolsters

MODEL FEATURES

- 1. Large swim platform
- 2. Walkthrough transom door
- 3. Livewell with cutting board
- 4. Optional port flip down seat or rod storage rack for 3 rods
- 5. Starboard flip down seat
- 6. Large fishing cockpit
- 7. Access walkway to foredeck
- 8. 2 cabin seats with slide/swivel & flip-up bolsters
- 9. Double berth with storage below and berth cushions
- 10. Optional seawater toilet
- 11. Integrated helm with hydraulic steering, SmartCraft instrumentation and optional 7" GPS and Bluetooth radio
- 12. Bow seat with cushion
- 13. Foredeck anchor locker and windlass
- 14. Sliding cabin entry door
- 15. Large glass windscreen for good visibility with windscreen wiper

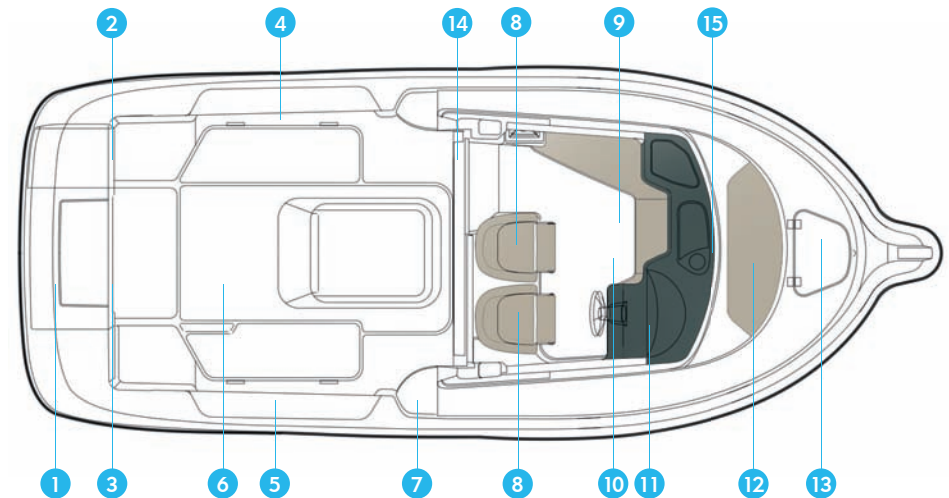



# ENGINES, SPECIFICATIONS & PACKS

## 690 ARVOR WITH MERCURY DIESEL QSD 2.0L – 115 HP

ENGINE SPECIFICATION	2.0L - 115 HP
Power	115 mhp – 84 kW
Max rpm	3000
Max torque	310 [Nm] @ 2400 rpm
Displ.	2.0 [l]
Cyl. layout	4 in Line
Eng. weight	250 [kg] – 551 [lbs]
Fuel inject.	Common Rail
Turbo	Water cooled
Cooling	Close Circuit
Fuel type	Diesel
Smart Craft	Standard



## 730 ARVOR WITH MERCURY DIESEL QSD 2.0L – 150 HP

ENGINE SPECIFICATION	2.0L - 150 HP
Power	150 mhp – 110 kW
Max rpm	4000
Max torque	310 [Nm] @ 2600 rpm
Displ.	2.0 [l]
Cyl. layout	4 in Line
Eng. weight	250 [kg] – 551 [lbs]
Fuel inject.	Common Rail
Turbo	Water cooled
Cooling	Close Circuit
Fuel type	Diesel
Smart Craft	Standard



## 810 ARVOR WITH MERCURY DIESEL QSD 2.8L – 220 HP

ENGINE SPECIFICATION	2.8L - 220 HP
Power	220 mhp – 160 kW
Max rpm	3800
Max torque	485 [Nm] @ 2600 rpm
Displ.	2.8 [l]
Cyl. layout	4 in Line
Eng. weight	360 [kg] – 794 [lbs]
Fuel inject.	Common Rail
Turbo	Water cooled
Cooling	Close Circuit
Fuel type	Diesel
Smart Craft	Standard
DTS	Standard



MODEL SPECIFICATIONS	810 ARVOR	730 ARVOR	690 ARVOR
Length Overall (M)	8,30	7,30	6,88
Length of Hull (M)	7,49	6,70	6,33
Beam Maximum (M)	2,93	2,78	2,54
Height - Without Canvas (M)	3,40	3,03	2,90
Dry Weight (Kg)	2775	1950	1740
Draft Hull with Max Engine (M)	0,88	0,86	0,75
Fuel Capacity (L)	300	200	90
CE Design Category	B	C	C
Maximum Number of People	8	7	6
Maximum Power (HP)	220	150	115
Maximum Power (kW)	161	110	84,6
Water Capacity (L)	80	50	0
Maximum load (Kg)	820	635	560

PACKS	810 ARVOR	730 ARVOR	690 ARVOR
<b>ELECTRONICS PACK SINGLE HELM</b>	x	x	x
Simrad GPS/Chart Plotter 9"	x	x	
Simrad GPS/Chart Plotter 7"			x
Stereo Fusion with 6 speakers	x	x	x
<b>ELECTRONICS PACK DUAL HELM</b>	x	x	x
Simrad GPS/Chart Plotter 9"	x	x	
Simrad GPS/Chart Plotter 7"	x	x	2x
Stereo Fusion with 6 speakers	x	x	x



COCKPIT	810 ARVOR	730 ARVOR	690 ARVOR
Cockpit Rod Storage	v	v	v
Rodholders	v	v	v
Raw Water Washdown	v	v	v
Bait Preparation Station	v	v	v
Livewell System	v	v	v
Self Bailing Cockpit	v	v	v
Port Flip Down Seat	v	o	o
Starboard Flip Down Seat	v	v	v
Transom Door	v	v	v
Second Helm Station	o	o	o
Cockpit Shower	v		

BOW	810 ARVOR	730 ARVOR	690 ARVOR
Bow Cushion	v	v	v

HELM	810 ARVOR	730 ARVOR	690 ARVOR
SmartCraft Speedometer/ Tachometer	v	v	v
Hydraulic Steering	v	v	v
12v Electrical Socket	v	v	v
Stereo	Elec	Elec	Elec
GPS/Chart plotter 7"	Elec 2H	Elec 2H	Elec 1H/2H
GPS/Chart plotter 9"	Elec 1H	Elec 1H	
Trolling Valve	v	v	v

CABIN	810 ARVOR	730 ARVOR	690 ARVOR
Berths	2	2	2
Berth Filler/Cushions	v	v	v
Cabin Lights	v	v	v
Interior Rod Racks	v		
Pilot & Co-pilot Seat	v	v	v
Jump Seat Filler	v		
Opening Side Window	v	v	v
Roof Hatch	v	v	v
Table/Dinette	v		
Fire Extinguisher	v	v	v
Sea Toilet	o <sup>2</sup>	o	o

GALLEY	810 ARVOR	730 ARVOR	690 ARVOR
Sink with Tap	v	v	
Pressure Fresh Water System	v	v	
Single Burner Stove	v	v <sup>1</sup>	v <sup>1</sup>

HEAD	810 ARVOR	730 ARVOR	690 ARVOR
Enclosed Sea toilet	o <sup>2</sup>		
Opening Portlight	v		

EQUIPMENT	810 ARVOR	730 ARVOR	690 ARVOR
Shore Power	v		
Diesel heat	o	o	o
Bow Thruster	v	v	
Bow Electrical Windlass	v	v	v
Transom Electric Windlass	o	o	o
Electric Trim Tabs	v	v	

HULL & DECK	810 ARVOR	730 ARVOR	690 ARVOR
Hull Color	o	o	o
Swim Ladder	v	v	v
Swim Platform	v	v	v
Bow Roller	v	v	v
Anchor Locker	v	v	v
Starboard Windshield Wiper	v	v	v
Port Windshield Wiper	v		
Navigation Lights	v	v	v
Electric Bilge Pump	v	v	v

COVER & CANVAS	810 ARVOR	730 ARVOR	690 ARVOR
Sun Awning	o	o	o
Exterior Helm Cover	o	o	o

v = Standard o = Optional  
 Elec 1H = Part of Electronic Pack - Offered on the Main Helm  
 Elec 2H = Part of Electronic Pack - Offered on the Second Helm

- 1 Portable
- 2 Sea toilet available in cabin or in separated head section



# **QUICKSILVER®**

Explore our dealer network at  
[www.quicksilver-boats.com](http://www.quicksilver-boats.com)

 **BRUNSWICK**  
GENUINE INGENUITY



The quality system of  
Brunswick Marine in EMEA  
is ISO 9001:2008 certified.

© 2016 Brunswick Marine in EMEA. All Rights Reserved.

Brunswick Marine in EMEA continuously explores means to improve the products it designs, manufactures and distributes. Every effort is made to produce sales and service literature which is current. Changes to specifications of engines, boats and accessories are ongoing. This brochure should not be regarded as a precise guide to the latest specifications. This brochure is also not an offer for sales of any particular engine, boat or accessory. Distributors and dealers are not agents of Brunswick Marine in EMEA or one of its affiliates and they have no authority to bind Brunswick Marine in EMEA by any express undertaking or representation, including but not limited to representations of product, sales, applications or service nature. Not all products are available in all countries and some are available only in limited quantities. Some products shown in this catalogue are equipped with optional accessories. Please see your local dealer.