



QUICKSILVER®
CAPTUR

Life is now





Welcome to the Captur range from Quicksilver.

Captur gives you the freedom of the water, the freedom to fish and the freedom to be spontaneous. Perfect for friends and serious fishermen – they offer everything you could need and more.

From day trippers to overnighters, these boats let you seek out life rather than just let it happen – to enjoy life to the full: carefree and worry-free. Boats with all the power, comfort and practicality to get you out there. Life is more fun when you remove the obstacles. Life is for living, for remembering. It's a journey.

Seize the moment.

Explore our complete range of boats and dealer network now at www.quicksilver-boats.com



QUICKSILVER®

Spirit to fish

Lazy summer days. A consuming all-year-round passion. However you like your fishing, the Captur range will help you make the most of every moment - year in, year out.

Captur is the safe and reliable choice for fishing – offering everything from greater on-board space to true trolling capability. It's a combination that's sure to capture the attention of any real fisherman.

The fish are biting. Are you ready to go?









CONTENTS

NEW 755 Pilothouse	10 - 13
640 Pilothouse	14 - 15
580 Pilothouse	16 - 17
530 Pilothouse	18 - 19
500 Pilothouse	20 - 21
280 Arvor	24 - 27
250 Arvor	28 - 31
230 Arvor	32 - 33
215 & 215 AS Arvor	34 - 35
500 Fish	36
440 Fish	36
410 Fish	37
360 Fish	37





Pilothouse

Pilothouse was developed with consideration and insight into the needs and desires of boat users. As a result, every Pilothouse offers you the freedom to get out and to the fish quickly and safely.

Whether you're after space and comfort for a social weekend away, or the practical touch of a live bait well equipped with seawater circulation, the Pilothouse is flexible enough to deliver just what you need.

Furthermore, all that practical ability is underpinned by the kind of structural integrity that will give you lasting enjoyment. Combined with a choice of powerful, reliable engines, a Pilothouse offers real peace of mind.

Where serious fishing and family fun are all in a day's play

A fishing trip is never going to be a rough and ready affair in this addition to the Pilothouse range. Combining the best fishing equipment package with a full interior double berth, the 755 brings fishing aficionados a real touch of luxury along with all the practical touches the seasoned boater would expect. Boasting the largest HP range, with single engine up to 250hp you'll be enjoying both speed and power.



SAFETY

In addition to the standard features you would expect for trouble-free boating such as navigation lights, sturdy swim ladder and well-placed grab rails, this is the only boat in its class to offer an electronics package for the covered exterior second helm, providing GPS/chartplotter. An electrical windlass takes the strain out of weighing anchor, whilst a bow thruster makes for easier docking. Whenever you want to take to the water, swim platforms make access on and off the boat simple and safe.

FISHING

This is where the 755 comes into its own, offering as it does the best fishing package with a premium livewell system, fishwell locker pumpout systems, additional rod holders and more. The fishing experience is maximised with the largest fishing cockpit, which allows for complete conversion thanks to flip-up flush-fitting seating to provide a clear area.

COMFORT

Nothing has been left to chance in anticipating your comfort. Even before the rigours of a day's serious fishing, the full double berth looks enticingly restful. Meanwhile on deck the walkthrough transom, combined with triple forward facing interior seating and dedicated galley area ensures ease of movement, comfort and a spacious feel throughout. A special comfort pack option will provide pleasure-seekers with mod cons such as bow cushions, table, refrigerator and a cockpit shower. With the additional options of a seawater toilet and interior curtains you will have all the conveniences you need to enjoy your adventures afloat.

STORAGE

In addition to the luxury fish locker, our savvy designers have integrated a wealth of practical touches to facilitate storage of all fishing and leisure equipment.



755 PILOTHOUSE

Model specifications

Length Overall (M)	7,39
Beam Maximum (M)	2,79
Height - Without Canvas (M)	2,83
Dry Weight (Kg)	1800
Fuel Capacity (L)	300
CE Design Category	C
Maximum Number of People	8
Maximum Power (HP/kW)	250/186

4 Packs

Fish Upgrade Pack:

- Raw water washdown
- Additional rod holders (2)
- Fish locker pumpouts (Electric)
- Bait preparation table

Comfort Pack:

- Hardtop opening roof hatch
- Foredeck opening portlight
- Cockpit shower
- Bow cushion
- Salon table
- Refrigerator

Single Helm Electronic Pack:

- GPS/Chartplotter 7" for main helm
- Sonic hub

Dual Helm Electronic Pack:

- GPS/Chartplotter 7" for main helm
- Sonic hub
- GPS/Chartplotter 5" for 2nd helm

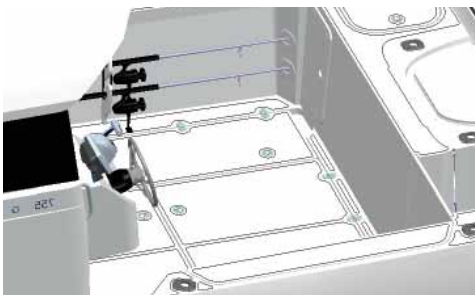



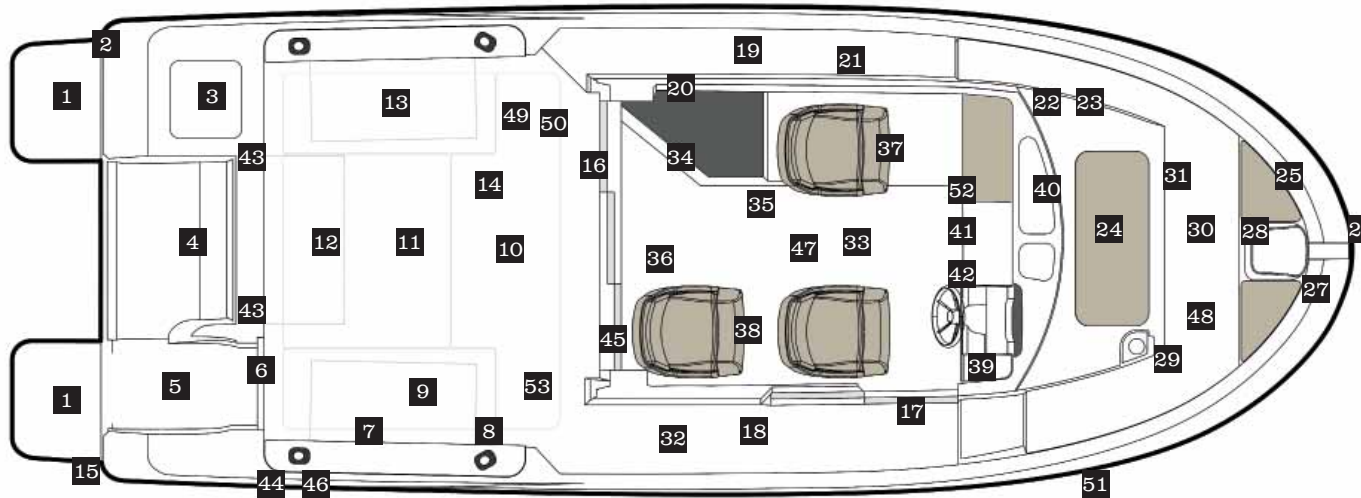

Model features

- | | | | |
|---|---|--|--|
| 1. Optional port & starboard swim platforms | 14. Optional cockpit table | 30. Recessed bow access/working area | 42. Optional seawater toilet |
| 2. Optional transom windlass | 15. Optional electric trim tabs | 31. Opening foredeck window (as part of options pack) | 43. 2 optional rodholders as part of fish pack |
| 3. Livewell | 16. Tri-slide aft cabin entry door | 32. Fiberglass hardtop with optional sliding opening roof hatch (as part of comfort pack) | 44. Optional raw water washdown (as part of fish pack) |
| 4. Optional bait preparation station (with Fish Pack) | 17. Pilothouse helm access sliding entry door | 33. Cabin floor storage lockers | 45. Optional cockpit helm and optional 5" second station electronics (GPS/chartplotter networked to primary system) with weather cover |
| 5. Telescoping stainless steel swim ladder (recessed under cover in transom access area) | 18. Cockpit level starboard pilothouse access walkway & recessed access to foredeck | 34. Dedicated galley with sink, fresh water system, and stove. Storage below galley. | 46. Optional cockpit shower (as part of comfort pack) |
| 6. Transom door | 19. Port recessed foredeck access walkway | 35. Optional refrigerator | 47. Optional cabin table (as part of comfort pack) |
| 7. Port & starboard rod storage racks under fiberglass coaming caps (2 rods per side) | 20. Optional shore power with battery charger | 36. Starboard storage locker (under seating) | 48. Optional bow thruster |
| 8. Rod holders port & starboard - 2 per side | 21. Port side opening sliding cabin window | 37. Pilot & copilot seats with slide/swivel & flip-up bolsters | 49. Optional cockpit canvas bimini top |
| 9. Fish lockers port & starboard with standard drains thru hull bottom and optional electric pumpout available with fish pack | 22. Tempered glass windshield | 38. Forward facing 3rd passenger seat with slide/swivel & flip-up bolsters | 50. Optional enclosure for cockpit canvas |
| 10. Cockpit floor storage & battery access | 23. Standard port & starboard pantograph windshield wipers | 39. Integrated helm with hydraulic steering, SmartCraft instrumentation, mounting area for optional 7" GPS/Depthfinder and sonic-hub entertainment system and 12v outlet | 51. Port & starboard opening hull portlights |
| 11. Cockpit service hatch with access to boat mechanical systems | 24. Forward facing bow seat with optional cushion (as part of comfort pack) | 40. Integrated dash storage with acrylic cover | 52. Interior rod rack for 2 rods |
| 12. Optional aft recessed flip down bench seat with seat & backrest cushion | 25. Aft facing bow seat with optional cushions (as part of comfort pack) | 41. Double berth with storage below and berth cushions | 53. Dual battery boxes with shutoff/crossover switch |
| 13. Optional port recessed flip down bench seat with seat & backrest cushion | 26. Stainless steel tilting bow roller | | |
| | 27. Foredeck anchor/line locker | | |
| | 28. Optional forward windlass | | |
| | 29. Port and starboard cupholders for foredeck seating | | |



The next level

If fishing is your consuming passion, then the Quicksilver 640 Pilothouse was created for you. A large cockpit features removable transom seats to deliver even greater space when fishing, while the transom features a live bait well equipped with an electric pump for seawater circulation. The 640 Pilothouse will take your fun and your sport to the next level.

SAFETY

To help you set your sights on a great fishing trip, the designers of the 640 Pilothouse kept a keen eye on safety. From clear navigation lights for signalling to grab rails on the bow, to the convenience of a sturdy swim ladder and an electric windlass for easy, worry free anchoring, nothing has been overlooked.

FISHING

Perfect for one. Ideal for two. The 640 Pilothouse delivers more than serious fishing – it ensures an incredible fishing experience. From a live bait well and pump to the picnic table and cooker that prepares your catch of the day, no other serious fisher comes close.

COMFORT

A good weekend's fishing needn't mean having to rough it. From a bright and airy cabin to double berths, a picnic table to plenty of premium deck space, you'll find so many thoughtful features you won't want to come ashore.

STORAGE

Space is maximised with well thought out storage including a conveniently placed anchor locker plus a bow roller to make lowering and raising the anchor quick and easy and fishing rod holders. There's even a place to store your catch with a live bait well equipped with an electric pump for seawater circulation.

Model specifications

Length Overall (M)	6,52	Fuel Capacity (L)	135
Beam Maximum (M)	2,54	CE Design Category	C
Height - Without Canvas (M)	2,65	Maximum Number of People	6
Dry Weight (Kg)	1060	Maximum Power (HP/kW)	150/110

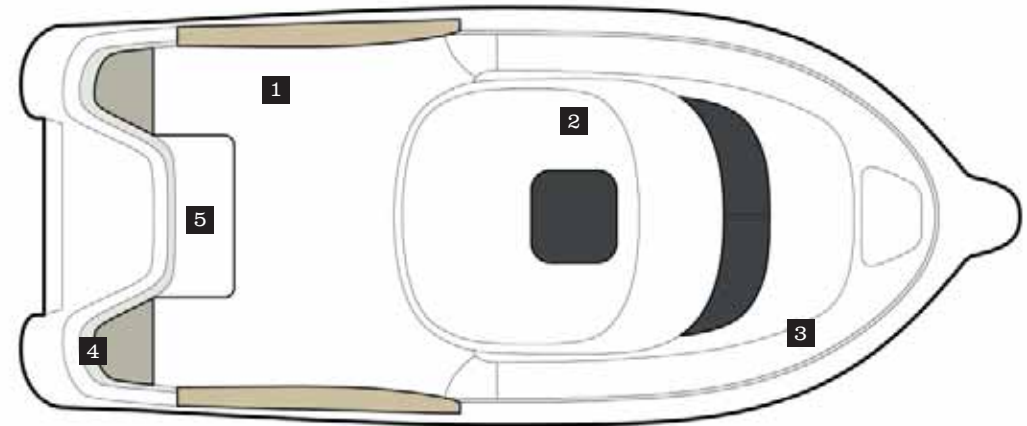

Model features

1. Large and clear cockpit to ease circulation and fishing
2. Wheelhouse completely enclosed with a sliding door to protect you against inclement weather
3. Large walk around to ease circulation while fishing
4. Removable backrest to ease access into the cockpit
5. Standard livewell with pump

As a company committed to continuous product improvement specifications are subject to change.





When fishing is your passion

The Quicksilver 580 Pilothouse packs all the features of the 640 Pilothouse, yet it does so within a slightly shorter frame. As a result, the 580 Pilothouse is a superb option for the keen fisherman. With double V-berths and a co-pilot seat, you're free to leave the world behind or team up with a friend.

SAFETY

A slightly smaller boat doesn't mean safety is compromised. In fact it's quite the opposite with everything you'd expect on board to put you at ease out on the water; from clear navigation lights for signalling to a windscreen wiper to maintain visibility, a robust swim ladder and a bilge pump as standard. There's even an electric windlass for safe, easy anchoring.

FISHING

The 580 Pilothouse is a real all-rounder with good storage, a cooker for making something tasty with all the catch from a great day's fishing, a removable chopping board to help with the cooking and a handy picnic table perfect for a quick snack or a more leisurely and sociable meal watching the sun go down.

COMFORT

When you're spending a busy day fishing it's good to know that the sliding door is effortless to use and gives easy access to the cockpit, while below deck there's all the welcome comfort of a bright cabin with double V-berths for a well earned rest. There's also a chemical WC for added comfort.

STORAGE

Forget the clutter. The 580 Pilothouse comes with a wealth of storage compartments, including fishing rod holders and an anchor locker. You'll have never felt so organised.

Model specifications

Length Overall (M)	5,95	Fuel Capacity (L)	90
Beam Maximum (M)	2,54	CE Design Category	C
Height - Without Canvas (M)	2,60	Maximum Number of People	6
Dry Weight (Kg)	1010	Maximum Power (HP/kW)	125/91,9

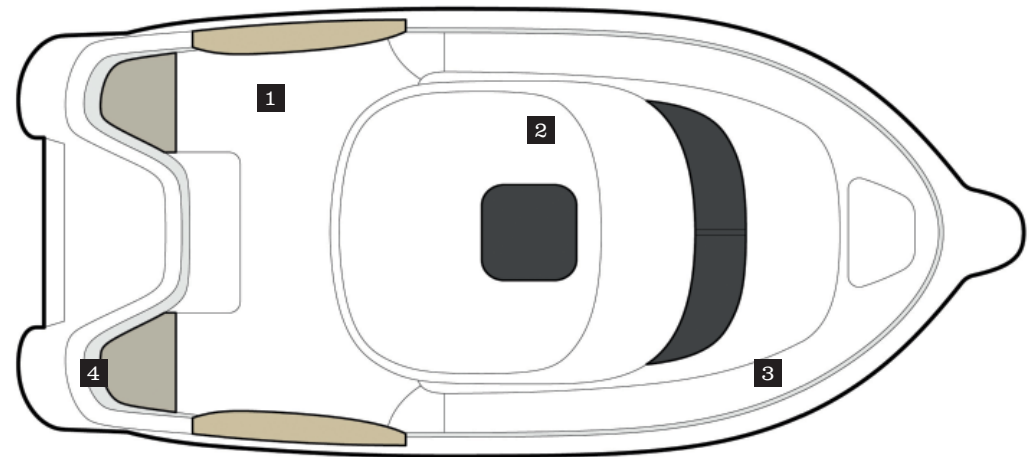

Model features

1. Large and clear cockpit to ease circulation and fishing
2. Wheelhouse completely enclosed with a sliding door to protect you against inclement weather
3. Large walk around to ease circulation while fishing
4. Removable backrest to ease access into the cockpit

As a company committed to continuous product improvement specifications are subject to change.





530 PILOTHOUSE

Open up to more fun

The Quicksilver 530 Pilothouse is paradise for any keen fisherman. Maximum space and light is created by the perfect combination of the open-backed cabin with a unique skylight. And if you want to make a great day's fishing really last there's a lockable cabin forwards with room for overnighting.

SAFETY

A slightly smaller boat doesn't mean safety is compromised. In fact it's quite the opposite with everything you'd expect on board to put you at ease out on the water; from clear navigation lights for signalling to a windscreen wiper to maintain visibility, a robust swim ladder and sturdy grab rails for safe, easy access to the bow. There's also a bilge pump as standard.

COMFORT

You'll always feel comfortable on board the 530 Pilothouse with the spacious, light and airy cabin, easy access around the boat and, when it's time to really unwind, a bright cabin with double V-berths for a well earned rest.

FISHING

The 530 Pilothouse is versatile through and through. Right from the folding co-pilot's seat that creates more space to the picnic table that will see you through the day, from a hearty breakfast to an evening meal savouring the day's catch and the best moments.

STORAGE

Considered storage throughout the boat is there to make every trip easy and enjoyable. A well-placed locker keeps the anchor out of harms way, while the bow roller means you can lower and raise the anchor without scratching the deck or hull. And naturally there are holders for your fishing rods.

Model specifications

Length Overall (M)	5,38	Fuel Capacity (L)	50
Beam Maximum (M)	2,39	CE Design Category	C
Height - Without Canvas (M)	2,45	Maximum Number of People	5
Dry Weight (Kg)	780	Maximum Power (HP/kW)	90/66,2

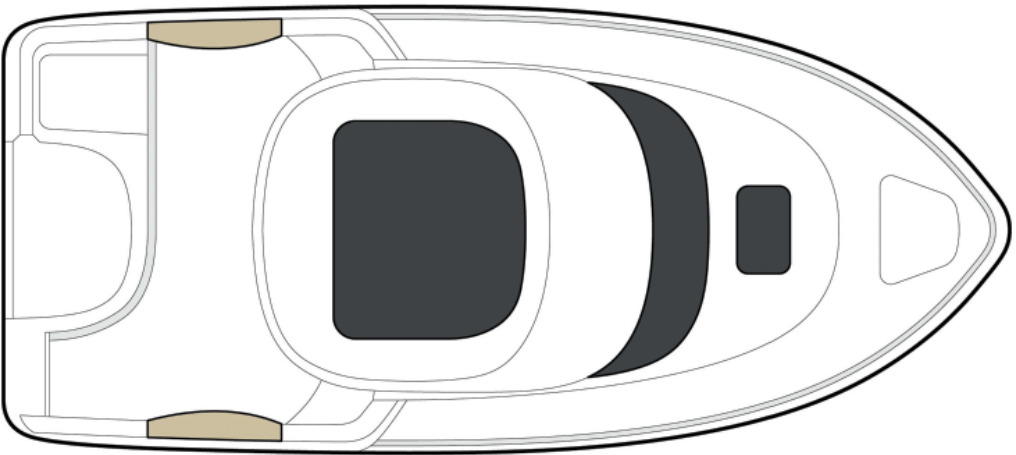

As a company committed to continuous product improvement specifications are subject to change.





Compact design for demanding fishermen

Welcome to the compact boat for fishermen that's big on versatility, comfort and practicality. Clever design means you can have the best of both worlds thanks to an offset cabin that gives you more room sheltered from the weather when you need it without sacrificing a secure portside passageway forward. So the 500 Pilothouse might be compact, but it thinks big.

SAFETY

With clear navigation lights for highly visible signalling, a windscreen wiper to maintain good visibility, a sturdy swim ladder to make getting in and out of the water safe and easy, a bilge pump as standard and hydraulic steering for smooth, fast yet safe driving, this is a boat that's built totally around your peace of mind.

COMFORT

Time to escape and unwind. You've got all you need to take it easy, from all the space you want on deck to a roomy fishing cockpit and a bright offset cabin complete with berths for when a day of fishing turns into a whole weekend of fun and pursuit.

FISHING

The 500 Pilothouse is the perfect fishing vessel combining useful space to get around the boat with room to shelter from the elements and all the practicality, comfort and safety you need to make your fishing trip really relaxing and worry-free.

STORAGE

The 500 Pilothouse boat has far more space and storage than you'd usually expect on a boat of this size. There's storage throughout the boat, including holders for those all-important fishing rods, an anchor locker to keep it safely out of the way plus a bow roller for lowering and raising the anchor.

Model specifications

Length Overall (M)	5,25	Fuel Capacity (L)	50
Beam Maximum (M)	2,35	CE Design Category	C
Height - Without Canvas (M)	2,30	Maximum Number of People	5
Dry Weight (Kg)	685	Maximum Power (HP/kW)	80/58,8

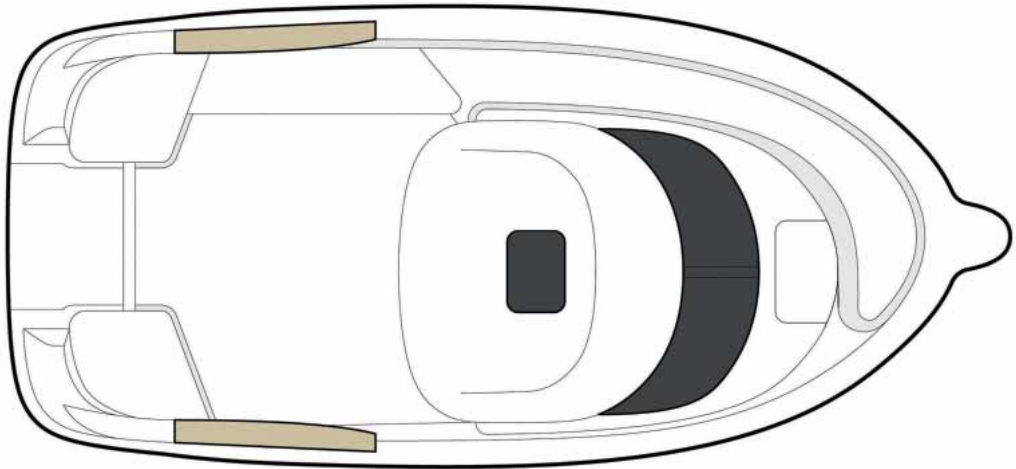

As a company committed to continuous product improvement specifications are subject to change.





QUICKSILVER



Arvor

This is the natural choice for fishing. A range of boats that combines reliability, practicality and technology to make all those trips memorable.

When it comes to power, you've got everything you need to get you there and back safely and smoothly. Solid diesel inboard engines blend higher displacement with the very latest advancements to deliver the performance, dependability and extreme trolling capability you need. Superior engine technology that also cuts fuel consumption and emissions.

For even greater reassurance, a low centre of gravity means a stable ride and position when you're fishing, while a transom door and high freeboards provide easy access getting in and around the boat. And to put you further at ease, the comfortable cabin includes a seating area that also turns into a berth.

You also get more space and fishing access aft – all helped by the propeller being neatly tucked away underneath. Add in rodholders, fish lockers, a cutting board and a livewell all as standard and there's nothing to get in the way of you and a great day's fishing.



QUICKSILVER®



280 ARVOR



The ultimate in luxury and practicality

In the world of Arvor practicality is never dull. We've used all our extensive experience to give you the perfect all round boat for fishing in the shape of the 280.

On board you'll discover that user-friendly design and thoughtful features meet a touch of luxury to make your fishing as enjoyable and comfortable as possible.

Ease of use is assured thanks to standard-fit hydraulic steering, bow thruster, trim tabs and dual electric wipers. While three electric bilge pumps, a trolling valve, an electric windlass and a revised, longer swinging bow roller help even more with life on board.

And for the true fisherman, the 280 Arvor's roomy cockpit boasts an aquarium-style livewell with pump, a fish locker and three wooden foldable benches where you can sit back, relax and discuss the day's catch.

So if you demand and expect the very best from a fishing boat, you've found it.



SAFETY

- Low centre of gravity ensures stable ride of the boat and stable position while fishing
- High freeboard for fisherman safety
- Transom door to ease access in and out of the boat
- Three electric bilge pumps

COMFORT

- Four-berth accommodation provides ample overnight space
- Additional facilities include both a baggage and toilet compartment
- The galley features a sink and tap together with a cooker and a storage container
- Comfortable cabin with pilot and co-pilot seat
- The helm is equipped with full engine instrumentation and an electric switch panel with circuit breakers. The pilothouse is very accessible thanks to its sliding door at portside
- Hydraulic steering makes driving and manoeuvring a true pleasure
- A standard electric windlass to ease mooring
- A standard bow thruster to ease docking

FISHING

- Integrated trolling valve into the transmission allows extreme slow trolling for hours without risk of damage to the engine or transmission
- Thanks to the inboard engine, fishing line does not easily get caught in the propeller
- Clear and non-obstructed view on the rear to ease fishing all around the cockpit
- A lot of fishing equipment comes as standard such as integrated rodholders, fish lockers, cutting board and livewell with pump
- The 280 Arvor has a very roomy cockpit with three wooden foldable cockpit benches

STORAGE

- A lot of storage available for fishing equipment in the wheelhouse
- Fish lockers in the cockpit to keep your catch of the day

Model specifications

Length Overall (M)	9,50	Fuel Capacity (L)	390
Beam Maximum (M)	2,99	CE Design Category	B
Height - Without Canvas (M)	3,70	Maximum Number of People	9
Weight of the boat (Kg) (including engine)	3700	Maximum Power (HP/kW)	320/235

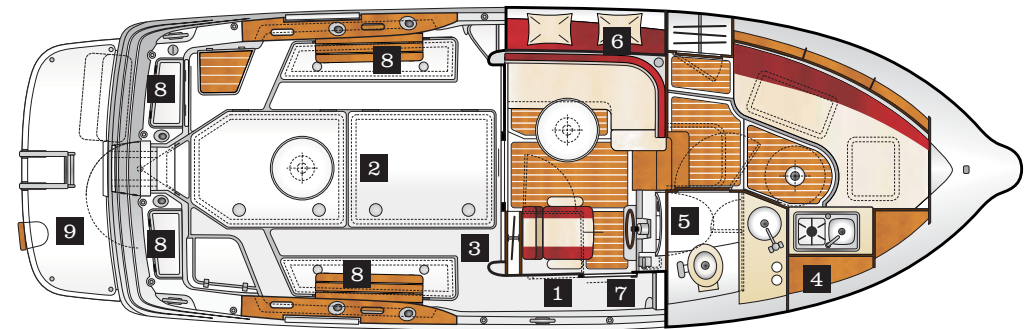

Model features

1. Asymmetric wheelhouse with a wide and safe passage to the bow on starboard
2. Large and clear cockpit for intensive fishing activities
3. Optional second helm station to allow driving from the cockpit
4. Permanent galley with single burner stove and sink to cook your catch of the day
5. Enclosed chemical toilet and lavatory sink
6. Separate berth to spend the night on board while mooring
7. Sliding wheelhouse portside door
8. The boat is fully equipped for fishing expedition: livewell with pump, rodholders, gunwale rollers and cutting board
9. Transom door to ease access in and out of the boat

As a company committed to continuous product improvement specifications are subject to change.



250 ARVOR



Enjoy your fishing in space, comfort and style

A standard bow thruster makes manoeuvring in port easier than ever while standard trim tabs simplify adjustment of your boat under different loads and sea conditions.

Additional standard equipment includes a trolling valve and an electric windlass.

A sink, cooker and table allow you to cook and eat your catch right on board. The head is neatly hidden below the steering position.

The big, open deck, with fold-down wooden benches, provides plenty of space to move around. The transom features an original livewell with an electric pump for seawater circulation and an aquarium-style window placed at waist height.

Further aft, the standard stern platform enables easy access and includes an auxiliary outboard engine bracket.

The 250 Arvor features vinyl cabin trim, tropical wood inserts and inside door finishes as well as teak laminate on the cabin and wheelhouse floor.





SAFETY

- Low centre of gravity ensures stable ride of the boat and stable position while fishing
- High freeboard for fisherman safety
- Transom door to ease access in and out of the boat
- Standard trim tabs simplify adjustment of your boat under different loads and sea conditions

FISHING

- Integrated trolling valve into the transmission allows extreme slow trolling for hours without risk of damage to the engine or transmission
- Thanks to the inboard engine, fishing line does not easily get caught in the propeller
- Clear and non-obstructed view on the rear to ease fishing all around the cockpit
- The big open deck, with fold-down wooden benches, provides plenty of space to move around. The transom features an original livewell with an electric pump for seawater circulation and an aquarium-style window placed at waist height

COMFORT

- Comfortable cabin with pilot and co-pilot seat, seating area that converts into berth
- Hydraulic steering makes driving and manoeuvring a true pleasure
- A standard electric windlass to ease mooring
- A standard bow thruster to ease docking
- A sink, cooker and table allow you to cook and eat your catch right on board
- The big open deck, with fold-down wooden benches, provides plenty of space to move around

STORAGE

- A lot of storage available for fishing equipment in the wheelhouse
- Fish lockers in the cockpit to keep your catch of the day

Model specifications

Length Overall (M)	8,30	Fuel Capacity (L)	300
Beam Maximum (M)	2,93	CE Design Category	B
Height - Without Canvas (M)	3,40	Maximum Number of People	8
Weight of the boat (Kg) (including engine)	2775	Maximum Power (HP/kW)	220/161

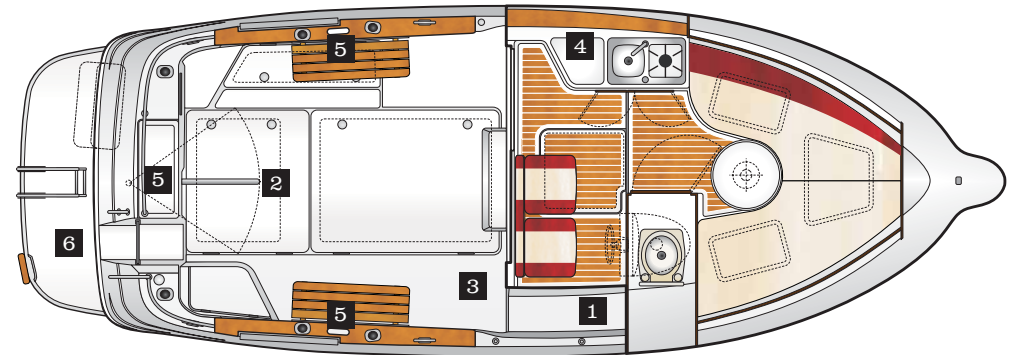

Model features

1. Asymmetric wheelhouse with a wide and safe passage to the bow on starboard
2. Large and clear cockpit for intensive fishing activities
3. Optional second helm station to allow driving from the cockpit
4. Permanent galley with single burner stove and sink to cook your catch of the day
5. The boat is fully equipped for fishing expedition: livewell with pump, rodholders, gunwale rollers and cutting board
6. Transom door to ease access in and out of the boat

As a company committed to continuous product improvement specifications are subject to change.



Enjoy more time on the water and more fish in the livewell

The 230 Arvor is a smaller sister to the popular 250 Arvor and offers a spacious cabin, a V-berth and a standard-fit chemical toilet.

It has a galley to port and a dining table in the cabin so you can cook and eat the catch of the day as soon as it comes on board!

For enhanced comfort at sea, equipment includes a bow thruster, a trolling valve and an electric windlass.

Also available in Deluxe version with vinyl cabin trim, tropical wood inserts and inside door finishes as well as teak laminate on the cabin and wheelhouse floor.

SAFETY

- Low centre of gravity ensures stable ride of the boat and stable position while fishing
- High freeboard for fisherman safety
- Transom door to ease access in and out of the boat
- Standard trim tabs make it easy to adjust your ship for different loads and sea conditions

FISHING

- Integrated trolling valve into the transmission allows extreme slow trolling for hours without risk of damage to the engine or transmission
- Thanks to the inboard engine, fishing line does not easily get caught in the propeller
- Clear and non-obstructed view on the rear to ease fishing all around the cockpit
- A livewell is set at waist height at the stern with an aquarium-style window for the entertainment of passengers. Rod holders, stainless steel net rollers, wooden gunwale are all standard

COMFORT

- Comfortable cabin with pilot and co-pilot seat, seating area that converts into berth
- Hydraulic steering makes driving and manoeuvring a true pleasure
- A standard electric windlass to ease mooring
- A standard bow thruster to ease docking
- It has a galley to port and a dining table in the cabin so you can cook and eat the catch of the day as soon as it comes on board
- Deluxe version with vinyl cabin trim, tropical wood inserts and inside door finishes as well as teak laminate on the cabin and wheelhouse floor

STORAGE

- A lot of storage available for fishing equipment in the wheelhouse
- Fish lockers in the cockpit to keep your catch of the day

Model specifications

Length Overall (M)	7,30	Fuel Capacity (L)	135 Standard / 200 Option
Beam Maximum (M)	2,78	Design Category	C
Height - Without Canvas (M)	3,03	Maximum Number of People	6
Weight of the boat (Kg) (including engine)	2005	Maximum Power (HP/kW)	150/110

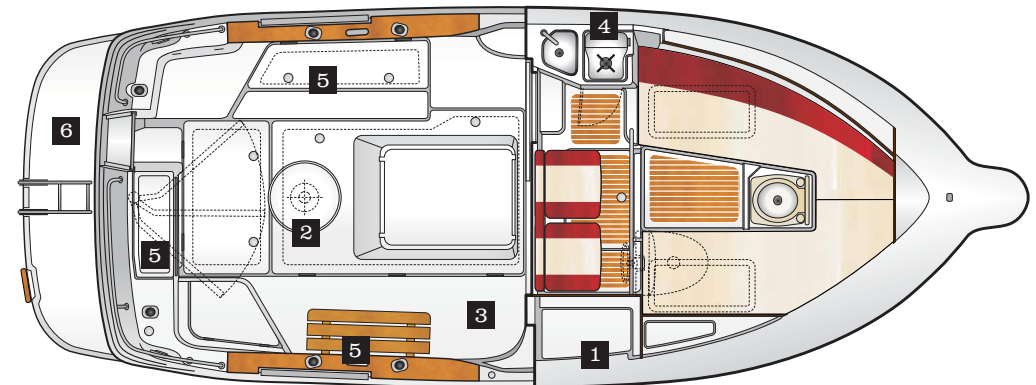

Model features

1. Asymmetric wheelhouse with a wide and safe passage to the bow on starboard
2. Large and clear cockpit for intensive fishing activities
3. Optional second helm station to allow driving from the cockpit
4. Permanent galley with single burner stove and sink to cook your catch of the day
5. The boat is fully equipped for fishing expedition: livewell with pump, rodholders, gunwale rollers and cutting board
6. Transom door to ease access in and out of the boat

As a company committed to continuous product improvement specifications are subject to change.



All-weather fun, sport and comfort

The 215 has convenient handrails and bow rails all around the cabin to provide safe, secure movement throughout. While the 215AS maintains spaciousness below decks and ensures ease of movement thanks to its offset cabin.

A sliding door gives easy access to the cabin with 2 berths. Plenty of lockers and storage compartments keep the place tidy and belongings dry.

The hatch on the roof and the wide windscreen provide lots of light and a panoramic view.

Fishing comfort is guaranteed with a standard trolling valve and an electric windlass.

Other standard equipment includes a boarding ladder, bathing platform, electric bilge pump and electric windscreen wipers.

SAFETY

- Low centre of gravity ensures stable ride of the boat and stable position while fishing
- High freeboard for fisherman safety
- Transom door to ease access in and out of the boat

COMFORT

- Comfortable cabin with pilot and co-pilot seat, seating area that converts into berth
- Hydraulic steering makes driving and manoeuvring a true pleasure
- A sliding door gives easy access to the cabin with 2 berths

FISHING

- Integrated trolling valve into the transmission allows extreme slow trolling for hours without risk of damage to the engine or transmission
- Thanks to the inboard engine, fishing line does not easily get caught in the propeller
- Clear and non-obstructed view on the rear to ease fishing all around the cockpit
- A lot of fishing equipment comes as standard such as integrated rodholders, fish lockers, cutting board and livewell with pump

STORAGE

- A lot of storage available for fishing equipment in the wheelhouse
- Plenty of lockers and storage compartments keep the place tidy and belongings dry
- Fish lockers in the cockpit to keep your catch of the day

Model specifications

Length Overall (M)	6,88	Fuel Capacity (L)	90
Beam Maximum (M)	2,54	CE Design Category	C
Height - Without Canvas (M)	2,90	Maximum Number of People	6
Weight of the boat (Kg) (including engine)	1600 / AS 1650	Maximum Power (HP/kW)	115/84,6

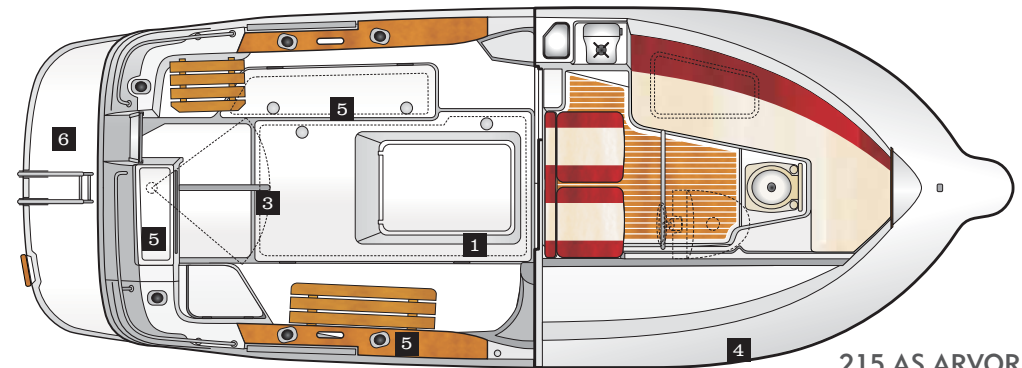

215 AS ARVOR

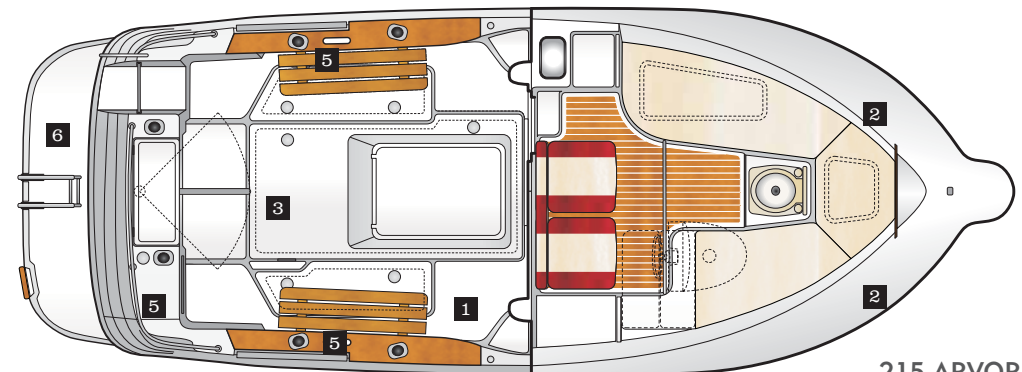

215 ARVOR

Model features

1. Optional second helm station to allow driving from the cockpit
2. Circulation around the cabin to fish from every part of the boat
3. Large and clear cockpit for intensive fishing activities
4. Asymmetric wheelhouse with a wide and safe passage to the bow on starboard
5. The boat is fully equipped for fishing expedition: livewell with pump, rodholders, gunwale rollers and cutting board
6. Transom door to ease access in and out of the boat

500 & 440 FISH

Lightweight and long lasting

These four 'no-fuss' boats provide wide open decks, and are perfect for utility, fishing or even simple family fun. Thanks to the multiple choice of propulsion (oars, tillersteer engine or remote console - depending on model), these boats are very versatile in their usage.

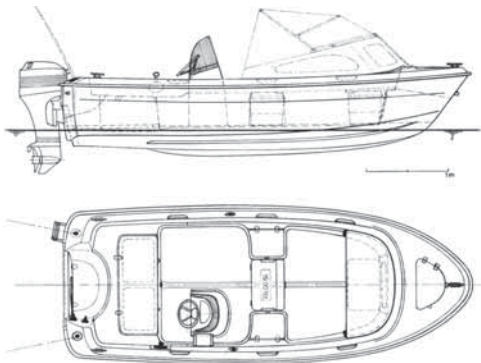

500 FISH: Tough and built to last

The 500 Fish - a boat of Scandinavian inspirations - brings the range a touch of tradition. With spacious and beamy cockpit, the 500 Fish can carry up to 6 people. It can take up to a 60 HP outboard and comes with a standard pilot console

Model features:

- Comfort: Spacious cockpit with pilot console.
- Life on board: Lateral benches, front and lateral storage area including a place to stow the optional ice-chest. Anchor locker, oarlocks, swim ladder and stainless steel cleats.
- Optional: Windshield.

Model specifications

Length Overall (M)	5,15	Shaft Length	L
Beam Maximum (M)	2,05	CE Design Category	C
Height - Without Canvas (M)	1,55	Maximum Number of People	6
Dry Weight (Kg)	415	Maximum Power (HP/kW)	60/44,1

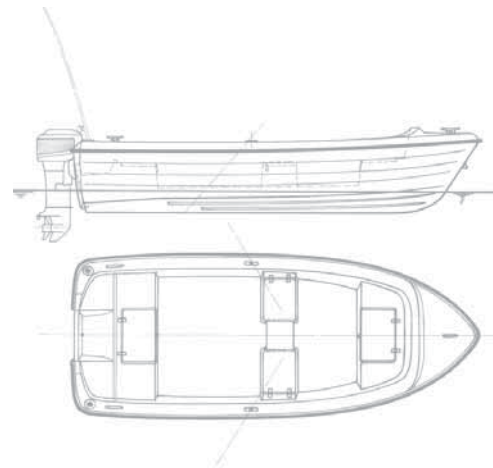

440 FISH: Passion for fishing

The Quicksilver 440 Fish will take an outboard engine or is light enough to row. It offers lots of storage space and it will become your best companion for fishing. An optional steering console is available to increase your driving comfort.

Model features:

- Comfort: Spacious cockpit with lateral benches and storage lockers.
- Life on board: Stainless steel cleats, mid-ship benches, oarlocks, swim ladder, ample storage, front and lateral storage compartments.
- Optional: Pilot console.

Model specifications

Length Overall (M)	4,40	Shaft Length	L
Beam Maximum (M)	1,78	CE Design Category	C
Height - Without Canvas (M)	1,04	Maximum Number of People	4
Dry Weight (Kg)	280	Maximum Power (HP/kW)	30/22,1

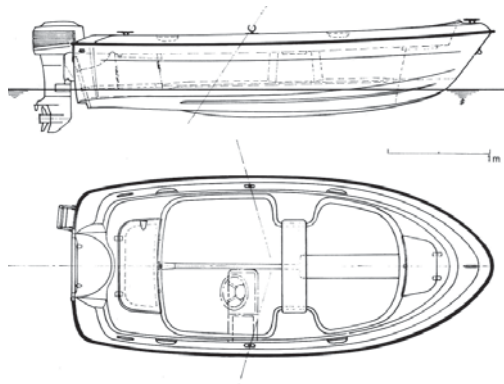

410 FISH: Even easier than ever

The Quicksilver 410 Fish is an adaptable open fishing boat that will take an outboard engine up to 20hp, yet is light enough to row. It can be supplied for a tiller-steer engine or with an optional steering console.

Model features:

Comfort: Mid-ship benches and grab rails.
Life on board: Swim ladder, storage lockers, oarlocks and stainless steel cleats.
Optional: Pilot console.

Model specifications

Length Overall (M)	4,12	Shaft Length	L
Beam Maximum (M)	1,85	CE Design Category	C
Height - Without Canvas (M)	0,93	Maximum Number of People	4
Dry Weight (Kg)	215	Maximum Power (HP/kW)	20/14,7

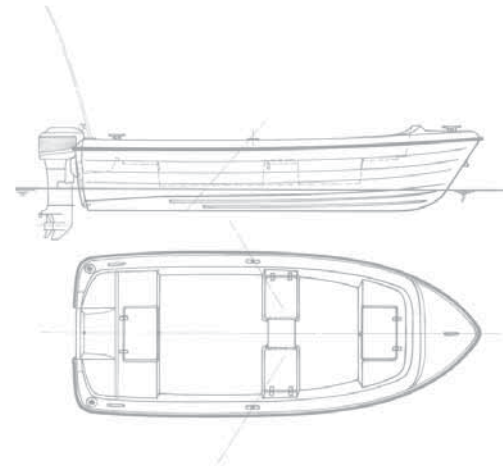

360 FISH: A great way to start boating

The Quicksilver 360 Fish completes the family of fishing boats. It can take an outboard engine or is light enough for you to use a pair of oars.

Model features:

Comfort: Mid-ship benches.
Life on board: Swim ladder, stainless steel cleats, storage lockers and oarlocks.

Model specifications

Length Overall (M)	3,78	Shaft Length	S
Beam Maximum (M)	1,71	CE Design Category	D
Height - Without Canvas (M)	0,72	Maximum Number of People	3
Dry Weight (Kg)	140	Maximum Power (HP/kW)	10/7,36

Inboard motors



Mercury Diesel

Combining the quiet, smooth performance of a traditional gasoline with the durability of a diesel, this four cylinder compact powerhouse features an advanced ECM with SmartCraft® compatibility to monitor various engine parameters. The QSD2.0 also features advanced components like the integrated heat exchanger and exhaust manifold, which also help reduce overall

package size. Impressive acceleration and precise throttle response are the result of a 16 valve cylinder head and a proven common rail fuel system that includes a turbocharger and seawater aftercooler.

HELM					COCKPIT				CABIN								ENGINE & MECHANICAL SYSTEMS		OPTIONS						INBOARD ENGINE OPTIONS								
Speedometer/Tachometer	Smartcraft Speedometer/Tachometer	Fuel Gauge	Hydraulic Steering	12v electrical socket	Aft Cockpit Seating	Port Cockpit Seating	Picnic Table	Co-pilot Seat	Opening Deck Hatch	Cabin Lights	Berths	Chemical Toilet	Flush Toilet with Overboard Discharge	Cabin Cushions	Opening Hull Portlights	Opening Side Window Hatch	Opening Hardtop Hatch	Trolling valve	Electric Bilge Pump	Deluxe Finish Interior	Second Helm Station	200 Liters Fuel Tank	Colored Hull	Fish upgrade Pack ²	Comfort Pack ³	Curtain Pack	Electronic Pack	Mercury Diesel 2.0L (115 HP-84.6 kW)	Mercury Diesel 2.0L (150 HP-110 kW)	Mercury Diesel 2.8L (220 HP-161 kW)	Mercury Diesel 4.2L (320 HP-235 kW)		
	v	v	v	v	o	o	o	v	o	v	2		o	v	v	v	o		v		o			o ¹	o	o	o	o					
v	o	v	v				v	v		v	2	v		v	v	v			v														
v		v	v				v	v		v	2	v		v	v	v	v		v														
v							v	v	v		2	o		v	v	v	v		v														
			v						v	v	1	o		v	v	v			v														
	v	v	v	v					v	v	4		v	v			v	v	v	v	v	o		o ¹								x	
	v	v	v	v				v	v	v	2	v		v		v	v	v	v	v	v	o		o ¹						x			
	v	v	v					v	v	v	2	v		v		v	v	v	v	v	o	o	o	o ¹									
	v	v	v					v	v	v	2	v		v		v	v	v	v	v	o			o ¹					x				

1 Dark blue for Arvor/Light grey for 755 Pilothouse | 2 Fish Upgrade Pack: raw water washdown, bait prep table, fish locker pumpouts, additional rod holders | 3 Comfort Pack: hardtop opening roof hatch, foredeck opening portlight, cockpit shower, salon table, bow cushions, refrigerator | v = Standard | o = Optional | As a company committed to continuous product improvement, specifications are subject to change.

QUICKSILVER®

Explore our dealer network at
www.quicksilver-boats.com

 **BRUNSWICK**
GENUINE INGENUITY



The quality system of
Brunswick Marine in EMEA
is ISO 9001:2000 certified.

© 2013 Brunswick Marine in EMEA. All Rights Reserved.

Brunswick Marine in EMEA continuously explores means to improve the products it designs, manufactures and distributes. Every effort is made to produce sales and service literature which is current. Changes to specifications of engines, boats and accessories are ongoing. This brochure should not be regarded as a precise guide to the latest specifications. This brochure is also not an offer for sales of any particular engine, boat or accessory. Distributors and dealers are not agents of Brunswick Marine in EMEA or one of its affiliates and they have no authority to bind Brunswick Marine in EMEA by any express undertaking or representation, including but not limited to representations of product, sales, applications or service nature. Not all products are available in all countries and some are available only in limited quantities. Some products shown in this catalogue are equipped with optional accessories. Please see your local dealer.